

# **A Course Module**

**on**

## **POWER SYSTEM ANALYSIS (20A02601T)**

**Prepared by**

**Dr.B.THRIVIKRAM**

**Assoc.Professor**

**Department of EEE**



**SREE RAMA ENGINEERING COLLEGE**

Approved by AICTE, New Delhi – Affiliated to JNTUA, Ananthapuramu

Accredited by NAAC with 'A' Grade

An ISO 9001:2015 & ISO 14001:2015 certified Institution

Rami Reddy Nagar, Karakambadi road, Tirupati-517507



**JAWAHARLAL NEHRU TECHNOLOGICAL UNIVERSITY ANANTAPUR**

**B.Tech (EEE)– III-II Sem**

**L T P C**  
**3 0 0 3**

**(20A02601T) POWER SYSTEM ANALYSIS**

**Course Objectives:**

- The use of per unit values and graph theory concepts, solving a problem using computer.
- Formation of  $Y_{bus}$  and  $Z_{bus}$  of a Power System network, power flow studies by various methods.
- Different types of faults and power system analysis for symmetrical and also unsymmetrical faults.
- Analysis of power system for steady state and transient stability and also methods to improve stability

**Course Outcomes:**

- Remember and understand the concepts of per unit values, Y Bus and Z bus formation, load flow studies, symmetrical and unsymmetrical fault calculations.
- Apply the concepts of good algorithm for the given power system network and obtain the converged load flow solution and experiment some of these methods using modern tools and examine the results.
- Analyse the symmetrical faults and unsymmetrical faults and done the fault calculations, analyse the stability of the system and improve the stability. Demonstrate the use of these techniques through good communication skills.
- Develop accurate algorithms for different networks and determine load flow studies and zero, positive and negative sequence impedances to find fault calculations.

**UNIT Ip. u. SYSTEM AND  $Y_{bus}$  FORMATION**

Per-Unit representation of Power system elements - Per-Unit equivalent reactance network of a three phase Power System - Graph Theory: Definitions, Bus Incidence Matrix,  $Y_{Bus}$  formation by Direct and Singular Transformation Methods, Numerical Problems.

**UNIT II FORMATION OF  $Z_{bus}$**

Formation of  $Z_{Bus}$ : Partial network, Algorithm for the Modification of  $Z_{BUS}$  Matrix for addition element for the following cases: Addition of element from a new bus to reference, Addition of element from a new bus to an old bus, Addition of element between an old bus to reference and Addition of element between two old busses - Modification of  $Z_{BUS}$  for the changes in network ( Problems )

**UNIT III POWER FLOW ANALYSIS**

Static load flow equations – Load flow solutions using Gauss Seidel Method: Algorithm and Flowchart. Acceleration Factor, Load flow Solution for Simple Power Systems (Max. 3-Buses): Newton Raphson Method in Polar Co-Ordinates Form: Load Flow Solution- Jacobian Elements, Algorithm and Flowchart. Decoupled and Fast Decoupled Methods.- Comparison of Different Methods

**UNIT IV SHORT CIRCUIT ANALYSIS**

Short Circuit Current and MVA Calculations, Fault levels, Application of Series Reactors. Symmetrical Component Theory: Positive, Negative and Zero sequence components, Positive, Negative and Zero sequence Networks. Symmetrical Fault Analysis: LLLG faults with and without fault impedance, Unsymmetrical Fault Analysis: LG, LL and LLG faults with and without fault impedance, Numerical Problems.

**UNIT V STABILITY ANALYSIS**

Elementary concepts of Steady State, Dynamic and Transient Stabilities. Derivation of Swing Equation, Power Angle Curve and Determination of Steady State Stability. Determination of Transient Stability by Equal Area Criterion, Application of Equal Area Criterion, Critical Clearing Angle Calculation. Numerical methods for solution of swing equation - Methods to improve Stability - Application of Auto Reclosing and Fast Operating Circuit Breakers.



**Textbooks:**

1. Computer Methods in Power System Analysis by G.W.Stagg and A.H.El-Abiad, Mc Graw-Hill, 2006.
2. Modern Power system Analysis by I.J.Nagrath&D.P.Kothari, Tata McGraw-Hill Publishing Company, 4<sup>th</sup> Edition, 2011.

**Reference Books:**

1. Power System Analysis by Grainger and Stevenson, McGraw Hill, 1994.
2. Power System Analysis by Hadi Saadat, McGraw Hill, 1998.
3. Power System Analysis and Design by B.R.Gupta, S. Chand & Company, 2005.

**Online Learning Resources:**

1. [https://onlinecourses.nptel.ac.in/noc22\\_ee120/preview](https://onlinecourses.nptel.ac.in/noc22_ee120/preview)

## MODERN POWER SYSTEM (OR) ELECTRIC ENERGY SYSTEM

### Over view of power system analysis

Power system consists of



### Components of power system.

Components of power system are

- Generators
- Transformers
- Transmission Lines
- Distribution Lines
- Loads
- Compensating Devices - Shunt compensators , Series compensators, Static VAR compensators

### Definition of Power System

The evaluation of Power system is called as Power system analysis

### Functions of Power System analysis:

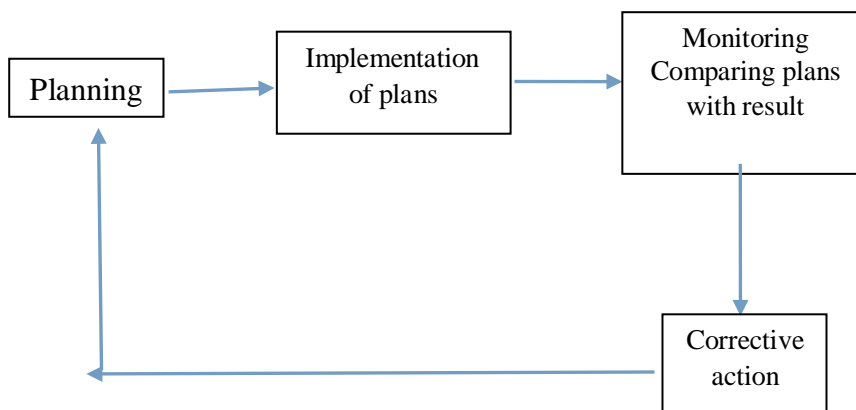
- To maintain the voltage at various buses real and reactive power flow between buses
- To design the circuit breakers
- To plan the future expansion of existing system
- To analyze the system under different fault conditions (three phase fault, L-G, L-L, L-L-G faults)
- To study the ability of the system for large disturbance (Sudden application of the large load)
- To study the ability of the system for small disturbance

### Natural Sources

- Coal
- Water flow
- Uranium & Thorium
- Fossil Fuel
- Wind
- Tidal
- Solar
- Bio-Gas

**ANALYSIS FOR SYSTEM PLANNING AND OPERATIONAL STUDIES****Needs for system analysis in planning and operation of power system**

- Planning and operation of power system - Operational planning covers the whole period ranging from the incremental stage of system development
- The system operation engineers at various points like area, space, regional & national load dispatch of power
- Power balance equation  $P_D = \sum_{i=1}^N PG_i$  This equation is satisfied it gives good economy and security
- Power system planning and operational analysis covers the maintenance of generation, transmission and distribution facilities

**Steps:**

- Planning of power system
- Implementation of the plans
- Monitoring system
- Compare plans with the results
- If no undesirable deviation occurs, then directly go to planning of system
- If undesirable deviation occurs then take corrective action and then go to planning Of the system

**Planning and operation of power system**

Planning and operation of power system the following analysis are very important

- (a). Load flow analysis
- (b). Short circuit analysis
- (c). Transient analysis

**Load flow analysis**

- Electrical power system operate - Steady state mode
- Basic calculation required to determine the characteristics of this state is called as Load flow
- Power flow studies - To determine the voltage current active and reactive power flows in given power system
- A number of operating condition can be analyzed including contingencies. That operating conditions are
  - (a). Loss of generator
  - (b). Loss of a transmission line
  - (c). Loss of transformer (or) Load
  - (d). Equipment over load (or) unacceptable voltage levels
- The result of the power flow analysis are starting point for the stability analysis and power factor improvement

- Load flow study is done during the planning of a new system or the extension of an existing one
- Short circuit studies**
- To determine the magnitude of the current flowing through out the power system at various time intervals after fault
- The objective of short circuit analysis - To determine the current and voltages at different location of the system corresponding to different types of faults
  - (a). Three phase to ground fault
  - (b). Line to ground fault
  - (c). Line to line fault
  - (d). Double line to ground fault
  - (e). Open conductor fault
- Transient stability analysis**
- The ability of the power system consisting of two (or) more generators to continue to operate after change occur on the system is a measure of the stability
- In power system the stability depends on the power flow pattern generator characteristics system loading level and the line parameters

## BASIC COMPONENTS OF A POWER SYSTEM.

### Structure of Power system

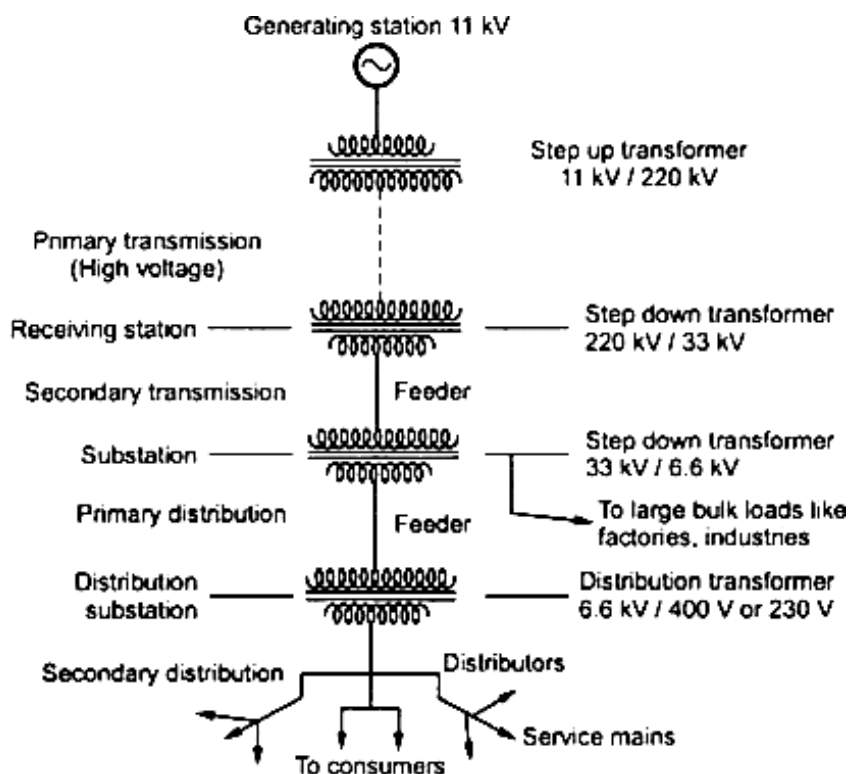


Fig 1.1 Structure of Power System

### Components of power system

Components of power system are in Fig 1.1

- Generators - Convert mechanical energy in to electrical energy
- Transformers - Transfer Power or energy from one circuit to another circuit with out change in frequency
- Transmission Lines - Transfer power from one place another place
- Control Equipment: Used for protection purpose

**CONCEPT OF REAL AND REACTIVE POWER**

Let 'V' be the Instantaneous voltage

Let 'i' be the Instantaneous current

$$V = V_m \sin \omega t$$

$$I = i_m \sin (\omega t - \Phi)$$

Radian frequency  $\omega = 2\pi f$

$$\begin{aligned} \text{Transmitter power } P &= V i \\ &= V_m \sin \omega t * i_m \sin (\omega t - \Phi) \\ &= \frac{V_m i_m}{2} (\cos \Phi - \cos (2\omega t - \Phi)) \end{aligned}$$

$$\text{RMS value of voltage } |V| = \frac{V_{\max}}{1.414}$$

$$\text{RMS value of current } |i| = \frac{i_{\max}}{1.414}$$


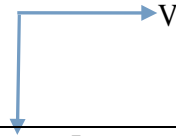
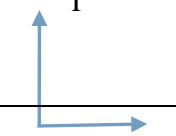
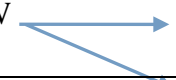

$$\begin{aligned} P &= |V| |i| [\cos \Phi - \cos (2\omega t - \Phi)] \\ &= |V| |i| \cos \Phi - |V| |i| \cos (2\omega t - \Phi) \\ &= |V| |i| \cos \Phi - |V| |i| (\cos 2\omega t \cos \Phi + \sin 2\omega t \sin \Phi) \\ &= |V| |i| \cos \Phi (1 - \cos 2\omega t) - |V| |i| \sin \Phi \sin 2\omega t \end{aligned}$$

$$P = P (1 - \cos 2\omega t) - Q \sin 2\omega t$$

Where active or useful or real power  $P = |V| |i| \cos \Phi$  watts

Non - active (or) Reactive power  $Q = |V| |i| \sin \Phi$  VAR

**Table 1.1 Phasor Relation with Real and reactive power**

Types of load	Phasor Diagram	Angle	Real power	Reactive power
R Load		$\Phi = 0$	$P > 0$	$Q = 0$
L Load		$\Phi = 90$ (lags)	$P = 0$	$Q > 0$
C Load		$\Phi = 90$ (Leads)	$P = 0$	$Q < 0$
RL Load		$0 < \Phi < 90$	$P > 0$	$Q > 0$
RC Load		$-90 < \Phi < 0$	$P > 0$	$Q < 0$

Inductive Load - Absorbs reactive power

Capacitive Load - Generate reactive power

Apparent Power: The product of RMS value of voltage and current

**MODELING OF COMPONENTS FOR LOAD FLOW ANALYSIS****Generator models****Generators:**

The thevenins equivalent circuit of the generator i.e. The voltage source in series with the thevenins equivalent impedance.  $Z = R + jX$

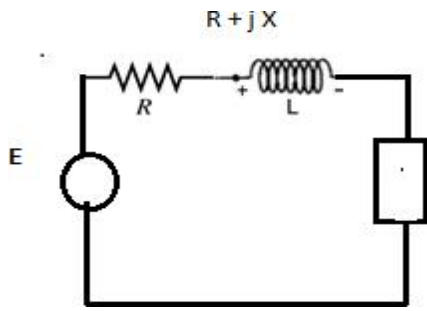


Fig 1.2 Basic model

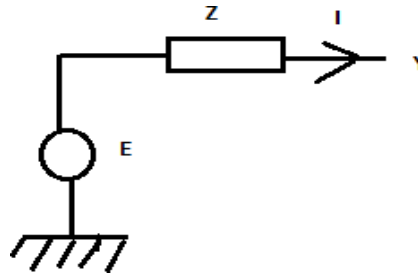


Fig 1.3 Equivalent circuit

The Norton form equivalent circuit of the generator i.e. The current source in parallel with the admittance

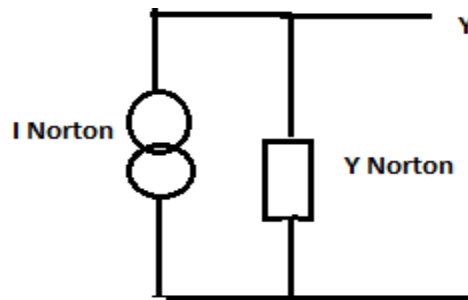


Fig 1.4 Norton Equivalent circuit

**Transformer model**

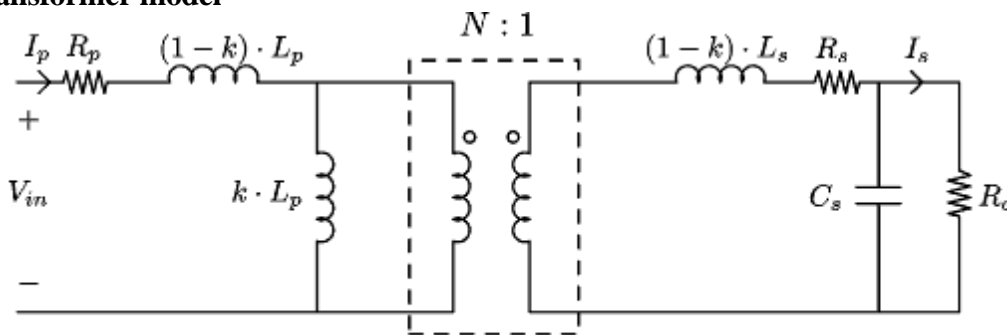


Fig. 5. Simplified model of a transformer.

**Transmission system model**

**Transmission Line**

Transmission line are modelled as (i). Short line model (ii). Medium line model (iii). **Long line model**

(i). Short line model : Resistance & inductance are assumed to be lumped



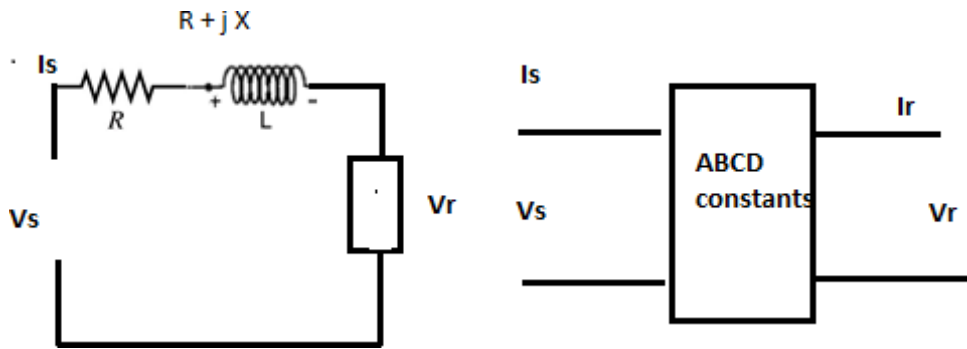


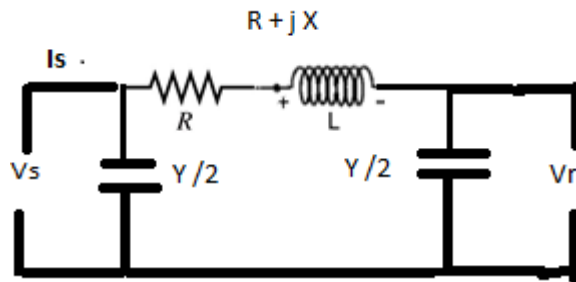
Fig 1.7 Equivalent transmission line model

ABCD parameters

$$\begin{bmatrix} V_s \\ I_s \end{bmatrix} = \begin{bmatrix} A & B \\ C & D \end{bmatrix} \begin{bmatrix} V_r \\ I_r \end{bmatrix}$$

**Medium line model (lines between 80 to 250km)**

Resistance & inductance are assumed to be lumped & the total shunt admittance is divided in to two equal parts & placed at the receiving and sending ends.



The Π model

Fig 1.8 Pi model

$$\begin{bmatrix} V_s \\ I_s \end{bmatrix} = \begin{bmatrix} A & B \\ C & D \end{bmatrix} \begin{bmatrix} V_r \\ I_r \end{bmatrix}$$

$$X = L\omega$$

$$Y/2 = C\omega/2$$

$$A = 1 + ZY/2$$

$$B = Z$$

$$C = Y(1 + ZY/4)$$

$$D = 1 + ZY/4$$

**Long line model (lines above 250)**

$$Z' = Z \sinh \gamma L / \gamma L$$

$$Y'/2 = 1/Zc \tanh(\gamma L/2)$$

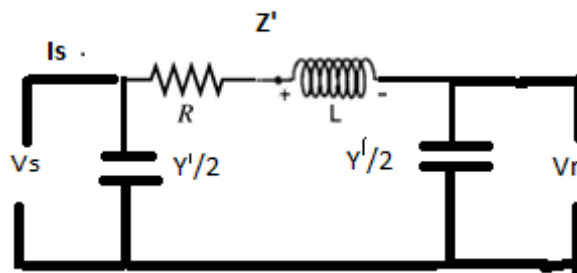


Fig 1.9 Medium line model

$$\begin{pmatrix} V_s \\ I_s \end{pmatrix} = \begin{pmatrix} \cosh \gamma l & Z_c \sinh \gamma l \\ 1/Z_c \sinh \gamma l & \cosh \gamma l \end{pmatrix} \begin{pmatrix} V_r \\ I_r \end{pmatrix}$$

**Shunt Elements:**

The shunt capacitor is connected to bus i. If S is MVAR rating of shunt capacitor. So is base MVA admittance P.u.  $Y_{P.u.} = 0+jS/S_0$

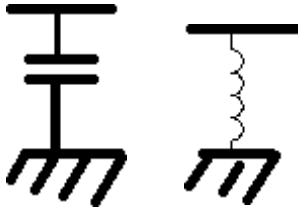


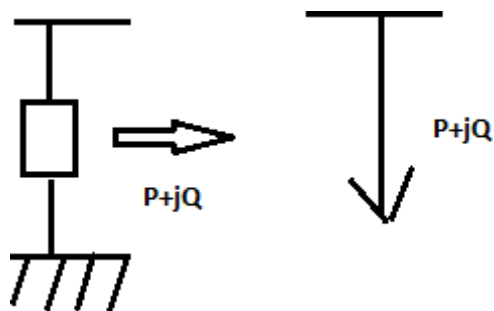
Fig 1.10 Shunt Elements

Shunt reactors is connected io bus i. If S is MVAR rating of shunt capacitor. So is base MVA admittance P.u.  $Y_{P.u.} = 0-jS/S_0$

**Load representation**

**Load:**

Load is represented by a constant power representation. Both MW (P) & MVAR (Q) - constant



**SINGLE LINE DIAGRAM**



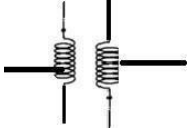
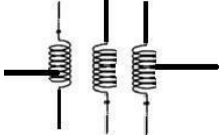


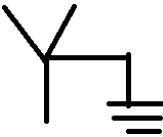







**Single line diagram**

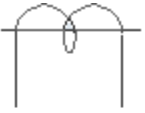

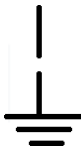
In general electrical power systems are represented by a one line diagram (or) single line diagram

A single line diagram of a power system shows the main connections & arrangements of components in a simplified manner

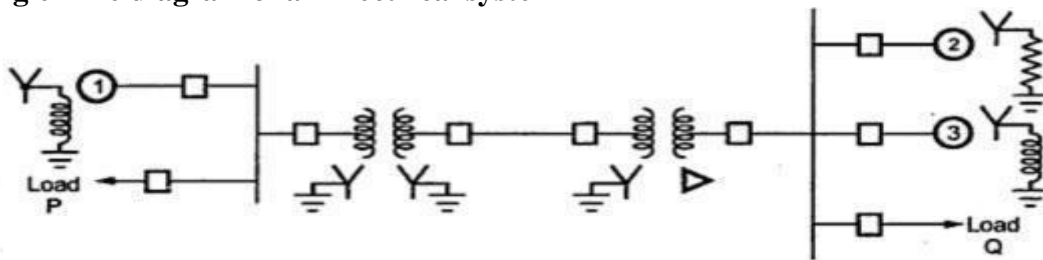
Pictorial representation of the entire power system from generating end to the consumer premises is known as single line diagram

**Standard symbols**

Sl.no	Components	Symbol
1	Rotating M/c(or) armature	
2	Bus	
3	Two winding power Transformer	
4	Three winding power Transformer	
5	Delta connection (3Φ, 3 wire)	
6	Wye connection (3Φ, neutral ungrounded)	
7	Wye connection (3Φ, neutral grounded)	
8	Transmission lines	
9	Static load	
10	Circuit Breaker	
11	Circuit Breaker (air)	
12	Disconnect	
13	Fuse	
14	Capacitor	

15	Current transformer	
16	Potential transformer	
17	Lighting arrester	

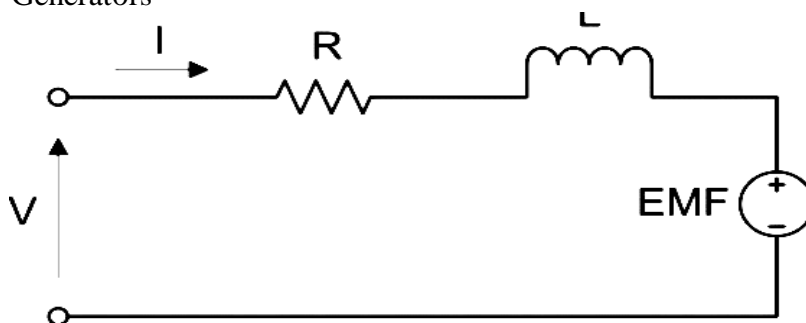
### Single Line diagram of an Electrical system



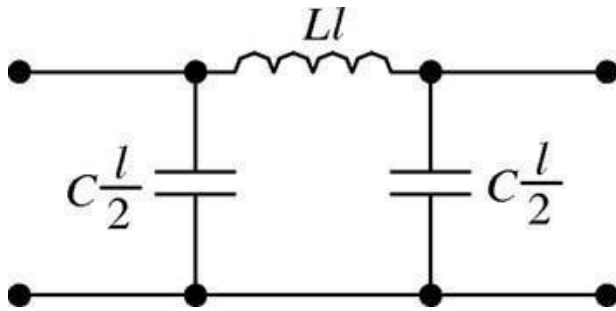
- One line diagram of a very simple power system
- Two generators one grounded through a reactor and one through a resistor connected to a bus and through a step up transformer to a transmission lines
- Another generator grounded a reactor is connected a bus and through a transformer to the opposite end of the transmission line
- A load is connected to each bus
- On the diagram information about the loads the ratings of the generators and transformers and reactance of different components of the circuit is often given
- It is important to know the location of points where a system is connected to ground to calculate the amount of current flowing when an unsymmetrical fault involving ground occur

### Equivalent circuit for various power system components:

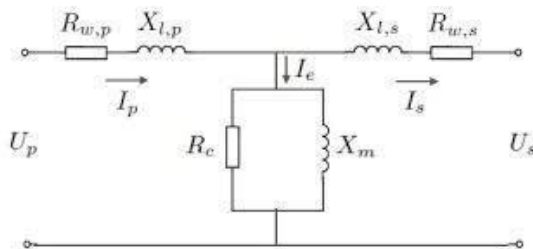
(i). Generators



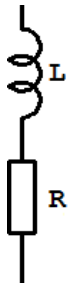
(ii). Transmission lines



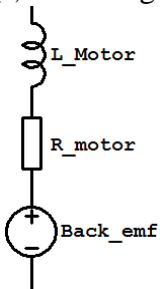
(iii). Transformer



(iv). Static load



(v). Rotating load (motor)



### IMPEDANCE DIAGRAM

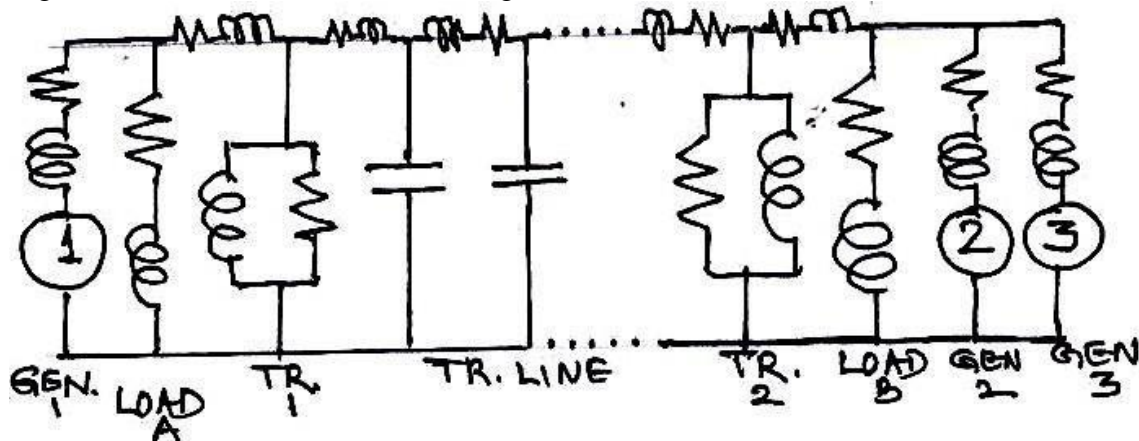
The impedance diagram on single-phase basis for use under balanced conditions can be easily drawn from the SLD. The following assumptions are made in obtaining the impedance diagrams.

#### Assumptions:

1. The single phase transformer equivalents are shown as ideals with impedance on appropriate side (LV/HV),
2. The magnetizing reactance of transformers are negligible,
3. The generators are represented as constant voltage sources with series resistance or reactance,
4. The transmission lines are approximated by their equivalent  $\pi$ -Models,
5. The loads are assumed to be passive and are represented by a series branch of resistance or reactance and
6. Since the balanced conditions are assumed, the neutral grounding impedance do not appear in the impedance diagram.

**Example system**

As per the list of assumptions as above and with reference to the system of figure 2, the impedance diagram can be obtained as shown in figure

**REACTANCE DIAGRAM**

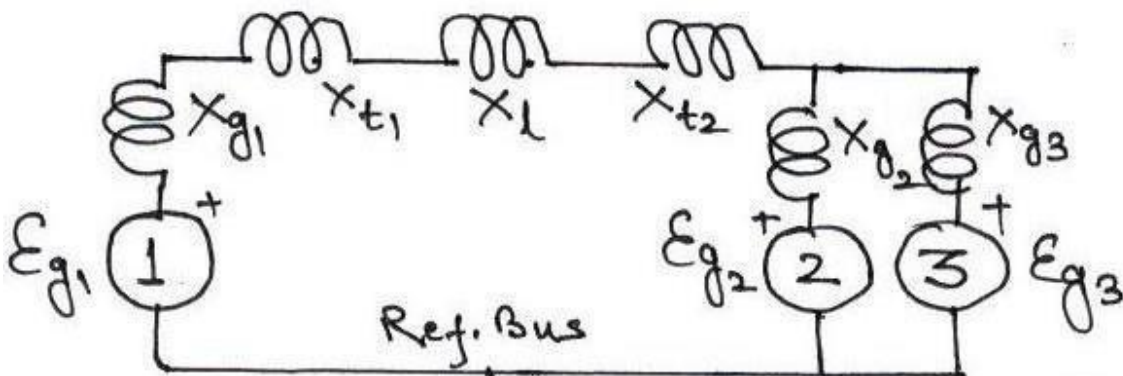
With some more additional and simplifying assumptions, the impedance diagram can be simplified further to obtain the corresponding reactance diagram. The following are the assumptions made.

**Additional assumptions:**

- The resistance is often omitted during the fault analysis. This causes a very negligible error since, resistances are negligible
- Loads are Omitted
- Transmission line capacitances are ineffective &
- Magnetizing currents of transformers are neglected.

**Example system**

as per the assumptions given above and with reference to the system of figure 2 and Figure, the reactance diagram can be obtained as shown in figure

**PER PHASE AND PER UNIT REPRESENTATION**

During the power system analysis, it is a usual practice to represent current, voltage, impedance, power, etc., of an electric power system in per unit or percentage of the base or reference value of the respective quantities. The numerical per unit (pu) value of any quantity is its ratio to a chosen base value of the same dimension. Thus a pu value is a normalized quantity with respect to the chosen base value.

**Definition:** Per Unit value of a given quantity is the ratio of the actual value in any given unit to

the base value in the same unit. The percent value is 100 times the pu value. Both the pu and percentage methods are simpler than the use of actual values. Further, the main advantage in using the pu system of computations is that the result that comes out of the sum, product, quotient, etc. of two or more pu values is expressed in per unit itself.

### Per unit value.

The per unit value of any quantity is defined as the ratio of the actual value of the any quantity to the base value of the same quantity as a decimal.

### Advantages of per unit system

- i. Per unit data representation yields valuable relative magnitude information.
- ii. Circuit analysis of systems containing transformers of various transformation ratios is greatly simplified.
- iii. The p.u systems are ideal for the computerized analysis and simulation of complex power system problems.
- iv. Manufacturers usually specify the impedance values of equivalent in per unit of the equipment rating. If the any data is not available, it is easier to assume its per unit value than its numerical value.
- v. The ohmic values of impedances are referred to secondary is different from the value as referee to primary. However, if base values are selected properly, the p.u impedance is the same on the two sides of the transformer.
- vi. The circuit laws are valid in p.u systems, and the power and voltages equations are simplified since the factors of  $\sqrt{3}$  and 3 are eliminated.

In an electrical power system, the parameters of interest include the current, voltage, complex power (VA), impedance and the phase angle. Of these, the phase angle is dimensionless and the other four quantities can be described by knowing any two of them. Thus clearly, an arbitrary choice of any two base values will evidently fix the other base values.

Normally the nominal voltage of lines and equipment is known along with the complex power rating in MVA. Hence, in practice, the base values are chosen for complex power (MVA) and line voltage (KV). The chosen base MVA is the same for all the parts of the system. However, the base voltage is chosen with reference to a particular section of the system and the other base voltages (with reference to the other sections of the systems, these sections caused by the presence of the transformers) are then related to the chosen one by the turns-ratio of the connecting transformer.

If  $I_b$  is the base current in kilo amperes and  $V_b$ , the base voltage in kilo volts, then the base MVA is,  $S_b = (V_b I_b)$ . Then the base values of current & impedance are given by

$$\begin{aligned} \text{Base current (kA), } I_b &= MVA_b / KV_b \\ &= S_b / V_b \end{aligned}$$

$$\begin{aligned} \text{Base impedance, } Z_b &= (V_b / I_b) \\ &= (KV_b^2 / MVA_b) \end{aligned}$$

Hence the per unit impedance is given by

$$\begin{aligned} Z_{pu} &= Z_{ohms} / Z_b \\ &= Z_{ohms} (MVA_b / KV_b^2) \end{aligned}$$

In 3-phase systems,  $KV_b$  is the line-to-line value &  $MVA_b$  is the 3-phase MVA. [1-phase MVA = (1/3) 3-phase MVA].

### CHANGE OF BASE.

It is observed from equation (3) that the pu value of impedance is proportional directly to the base

MVA and inversely to the square of the base KV. If  $Z_{pu\ new}$  is the pu impedance required to be calculated on a new set of base values:  $MVA_{b\ new}$  &  $KV_{b\ new}$  from the already given per unit impedance  $Z_{pu\ old}$ , specified on the old set of base values,  $MVA_{b\ old}$  &  $KV_{b\ old}$ , then we have

$$Z_{pu\ new} = Z_{pu\ old} (MVA_{b\ new}/MVA_{b\ old}) (KV_{b\ old}/KV_{b\ new})^2$$

On the other hand, the change of base can also be done by first converting the given pu impedance to its ohmic value and then calculating its pu value on the new set of base values.

### Merits and Demerits of pu System

Following are the advantages and disadvantages of adopting the pu system of computations in electric power systems:

#### Merits:

- The pu value is the same for both 1-phase and 3-phase systems
- The pu value once expressed on a proper base, will be the same when referred to either side of the transformer. Thus the presence of transformer is totally eliminated
- The variation of values is in a smaller range (nearby unity). Hence the errors involved in pu computations are very less.
- Usually the nameplate ratings will be marked in pu on the base of the name plate ratings, etc.

#### Demerits:

- If proper bases are not chosen, then the resulting pu values may be highly absurd (such as 5.8 pu, -18.9 pu, etc.). This may cause confusion to the user. However, this problem can be avoided by selecting the base MVA near the high-rated equipment and a convenient base KV in any section of the system.

### PU Impedance / Reactance Diagram

For a given power system with all its data with regard to the generators, transformers, transmission lines, loads, etc., it is possible to obtain the corresponding impedance or reactance diagram as explained above. If the parametric values are shown in pu on the properly selected base values of the system, then the diagram is referred as the per unit impedance or reactance diagram. In forming a pu diagram, the following are the procedural steps involved:

1. Obtain the one line diagram based on the given data
2. Choose a common base MVA for the system
3. Choose a base KV in any one section (Sections formed by transformers)
4. Find the base KV of all the sections present
5. Find pu values of all the parameters: R, X, Z, E, etc.
6. Draw the pu impedance/ reactance diagram.

### 1.12 FORMATION OF Y BUS & Z BUS

The performance equations of a given power system can be considered in three different frames of reference as discussed below:

#### Frames of Reference:

**Bus Frame of Reference:** There are  $b$  independent equations ( $b = \text{no. of buses}$ ) relating the bus vectors of currents and voltages through the bus impedance matrix and bus admittance matrix:

$$E_{BUS} = Z_{BUS} I_{BUS}$$

$$I_{BUS} = Y_{BUS} E_{BUS}$$



Bus Frame of Reference: There are  $b$  independent equations ( $b = \text{no. of buses}$ ) relating the bus vectors of currents and voltages through the bus impedance matrix and bus admittance matrix:

$$\text{EBUS} = \text{ZBUS IBUS}$$

$$\text{IBUS} = \text{YBUS EBUS}$$

Branch Frame of Reference: There are  $b$  independent equations ( $b = \text{no. of branches of a selected Tree sub-graph of the system Graph}$ ) relating the branch vectors of currents and voltages through the branch impedance matrix and branch admittance matrix:

$$\text{EBR} = \text{ZBR IBR}$$

$$\text{IBR} = \text{YBR EBR}$$

Loop Frame of Reference: There are  $b$  independent equations ( $b = \text{no. of branches of a selected Tree sub-graph of the system Graph}$ ) relating the branch vectors of currents and voltages through the branch impedance matrix and branch admittance matrix:

$$\text{ELOOP} = \text{ZLOOP ILOOP}$$

$$\text{ILOOP} = \text{YLOOP ELOOP}$$

Of the various network matrices referred above, the bus admittance matrix (YBUS) and the bus impedance matrix (ZBUS) are determined for a given power system by the rule of inspection as explained next.

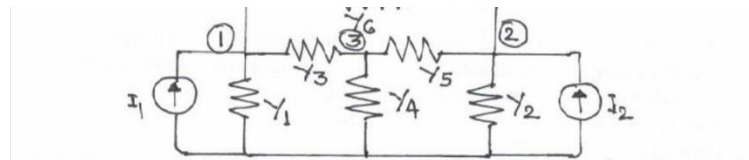
### Rule of Inspection

Consider the 3-node admittance network as shown in figure 5. Using the basic branch relation:  $I = (YV)$ , for all the elemental currents and applying Kirchhoff's Current Law principle at the nodal points, we get the relations as under:

$$\text{At node 1: } I_1 = Y_1 V_1 + Y_3 (V_1 - V_3) + Y_6 (V_1 - V_2)$$

$$\text{At node 2: } I_2 = Y_2 V_2 + Y_5 (V_2 - V_3) + Y_6 (V_2 - V_1)$$

$$\text{At node 3: } 0 = Y_3 (V_3 - V_1) + Y_4 V_3 + Y_5 (V_3 - V_2)$$



i.

These are the performance equations of the given network in admittance form and they can be represented in matrix form as:

$$\begin{bmatrix} I_1 \\ I_2 \\ 0 \end{bmatrix} = \begin{bmatrix} (Y_1 + Y_3 + Y_6) & -Y_6 & -Y_3 \\ -Y_6 & (Y_2 + Y_5 + Y_6) & -Y_5 \\ -Y_3 & -Y_5 & (Y_3 + Y_4 + Y_5) \end{bmatrix} \begin{bmatrix} V_1 \\ V_2 \\ V_3 \end{bmatrix}$$

In other words, the relation of equation (9) can be represented in the form  $\text{IBUS} = \text{YBUS EBUS}$

Where, YBUS is the bus admittance matrix, IBUS & EBUS are the bus current and bus voltage vectors respectively.

By observing the elements of the bus admittance matrix, YBUS of equation (9), it is observed that the matrix elements can as well be obtained by a simple inspection of the given system diagram:

Diagonal elements: A diagonal element ( $Y_{ii}$ ) of the bus admittance matrix, YBUS, is equal to the sum total of the admittance values of all the elements incident at the bus/node  $i$ ,

Off Diagonal elements: An off-diagonal element ( $Y_{ij}$ ) of the bus admittance matrix,  $Y_{BUS}$ , is equal to the negative of the admittance value of the connecting element present between the buses  $i$  and  $j$ , if any.

This is the principle of the rule of inspection. Thus the algorithmic equations for the rule of inspection are obtained as:

$$Y_{ii} = \sum y_{ij} \quad (j = 1, 2, \dots, n)$$

$$Y_{ij} = -y_{ij} \quad (j = 1, 2, \dots, n)$$

For  $i = 1, 2, \dots, n$ ,  $n$  = no. of buses of the given system,  $y_{ij}$  is the admittance of element connected between buses  $i$  and  $j$  and  $y_{ii}$  is the admittance of element connected between bus  $i$  and ground (reference bus).

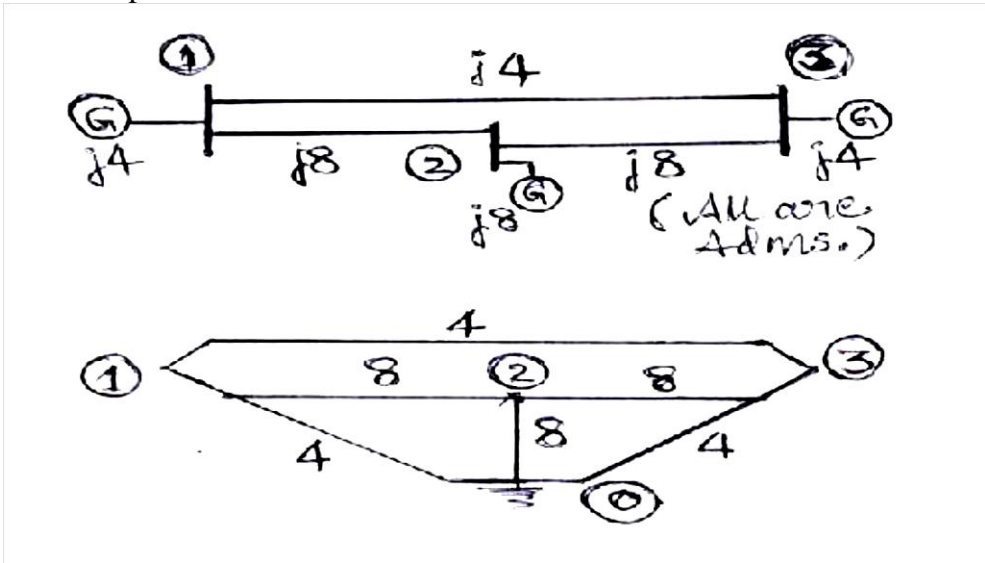
**Bus impedance matrix**

In cases where, the bus impedance matrix is also required, then it cannot be formed by direct inspection of the given system diagram. However, the bus admittance matrix determined by the rule of inspection following the steps explained above, can be inverted to obtain the bus impedance matrix, since the two matrices are inter-invertible.

**Note:** It is to be noted that the rule of inspection can be applied only to those power systems that do not have any mutually coupled elements.

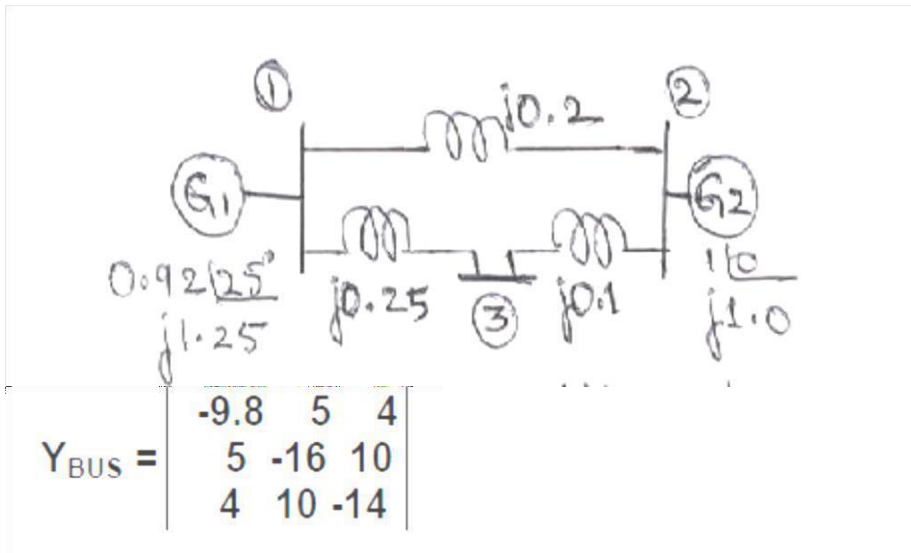
**EXAMPLES ON RULE OF INSPECTION:**

**Problem #1:** Obtain the bus admittance matrix for the admittance network shown aside by the rule of inspection



$$Y_{BUS} = \begin{vmatrix} 16 & -8 & -4 \\ -8 & 24 & -8 \\ -4 & -8 & 16 \end{vmatrix}$$

**Problem #2:** Obtain  $Y_{BUS}$  and  $Z_{BUS}$  matrices for the impedance network shown aside by the rule of inspection. Also, determine  $Y_{BUS}$  for the reduced network after eliminating the eligible unwanted node. Draw the resulting reduced system diagram.



$$Z_{BUS} = Y_{BUS}^{-1}$$

**EXAMPLES ON PER UNIT ANALYSIS:**

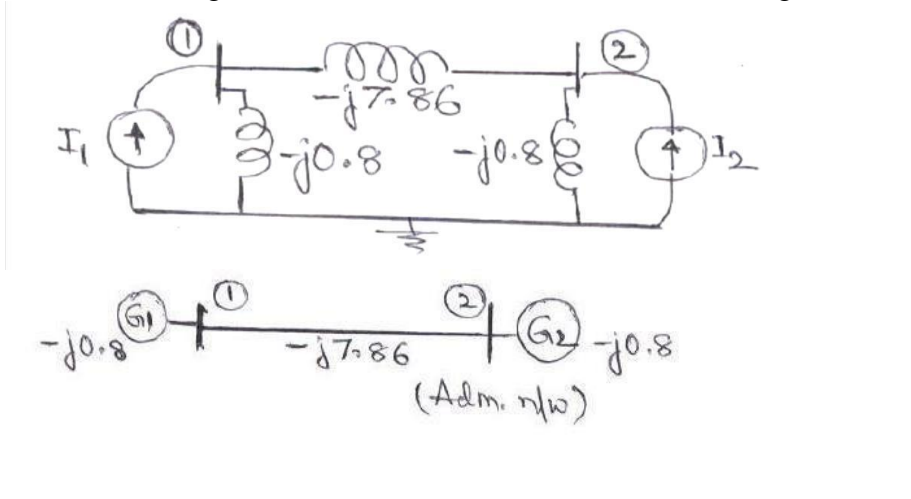
**Problem #1:**

Two generators rated 10 MVA, 13.2 KV and 15 MVA, 13.2 KV are connected in parallel to a bus bar. They feed supply to 2 motors of inputs 8 MVA and 12 MVA respectively.

The operating voltage of motors is 12.5 KV. Assuming the base quantities as 50 MVA, 13.8 KV, draw the per unit reactance diagram. The percentage reactance for generators is 15% and that for motors is 20%.

**Solution:**

The one line diagram with the data is obtained as shown in figure



$$Y_{BUS}^{New} = Y_A - Y_B Y_D^{-1} Y_C$$

$$Y_{BUS} = \begin{vmatrix} -8.66 & 7.86 \\ 7.86 & -8.86 \end{vmatrix}$$

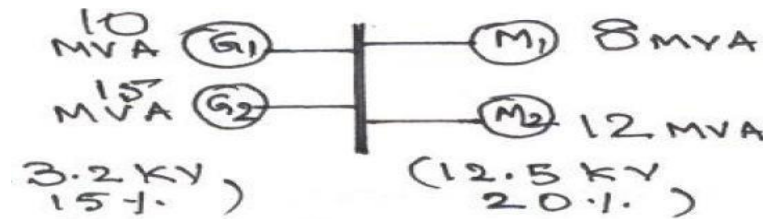
**EXAMPLES ON PER UNIT ANALYSIS:**

**Problem #1:**

Two generators rated 10 MVA, 13.2 KV and 15 MVA, 13.2 KV are connected in parallel to a bus bar. They feed supply to 2 motors of inputs 8 MVA and 12 MVA respectively. The operating voltage of motors is 12.5 KV. Assuming the base quantities as 50 MVA, 13.8 KV, draw the per unit reactance diagram. The percentage reactance for generators is 15% and that for motors is 20%.

**Solution:**

The one line diagram with the data is obtained as shown in figure P1



Selection of base quantities: **50 MVA, 13.8 KV** (Given)

Calculation of pu values:

$$X_{G1} = j 0.15 (50/10) (13.2/13.8)^2 = j 0.6862 \text{ pu.}$$

$$X_{G2} = j 0.15 (50/15) (13.2/13.8)^2 = j 0.4574 \text{ pu.}$$

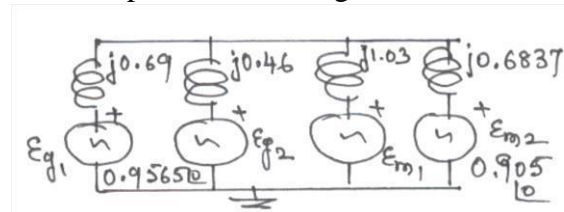
$$X_{m1} = j 0.2 (50/8) (12.5/13.8)^2 = j 1.0256 \text{ pu.}$$

$$X_{m2} = j 0.2 (50/12) (12.5/13.8)^2 = j 0.6837 \text{ pu.}$$

$$E_{g1} = E_{g2} = (13.2/13.8) = 0.9565 \text{ pu}$$

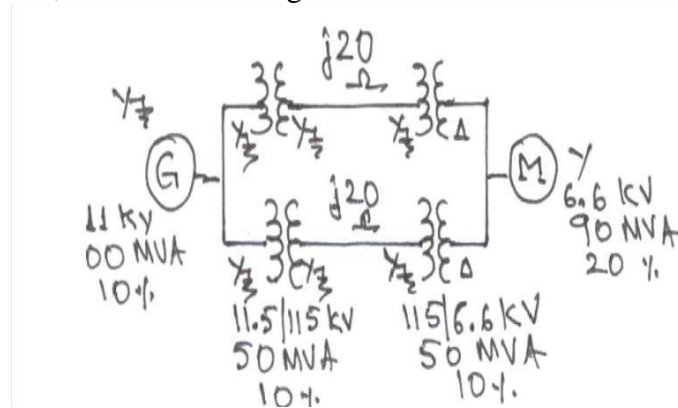
$$E_{m1} = E_{m2} = (12.5/13.8) = 0.9058 \text{ pu}$$

Thus the pu reactance diagram can be drawn as shown in figure P1



**Problem #2:**

Draw the per unit reactance diagram for the system shown in figure below. Choose a base of 11 KV, 100 MVA in the generator circuit.



**Solution:**

The one line diagram with the data is considered as shown in figure.

Selection of base quantities:

**100 MVA, 11 KV** in the generator circuit(Given); the voltage bases in other sections are: 11 (115/11.5) = **110 KV** in the transmission line circuit and 110 (6.6/11.5) = **6.31 KV** in the motor circuit.

Calculation of pu values:

$$X_G = j 0.1 \text{ pu}, X_m = j 0.2 (100/90) (6.6/6.31)^2 = j 0.243 \text{ pu.}$$

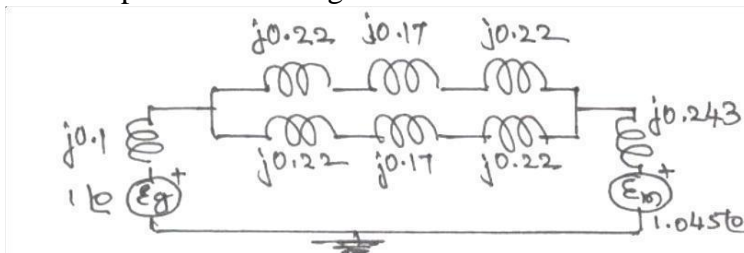
$$X_{t1} = X_{t2} = j 0.1 (100/50) (11.5/11)^2 = j 0.2185 \text{ pu.}$$

$$X_{t3} = X_{t4} = j 0.1 (100/50) (6.6/6.31)^2 = j 0.219 \text{ pu.}$$

$$X_{lines} = j 20 (100/110^2) = j 0.1652 \text{ pu.}$$

$$E_g = 1.0 \text{ pu}, E_m = (6.6/6.31) = 1.045 \text{ pu}$$

Thus the pu reactance diagram can be drawn as shown in fig

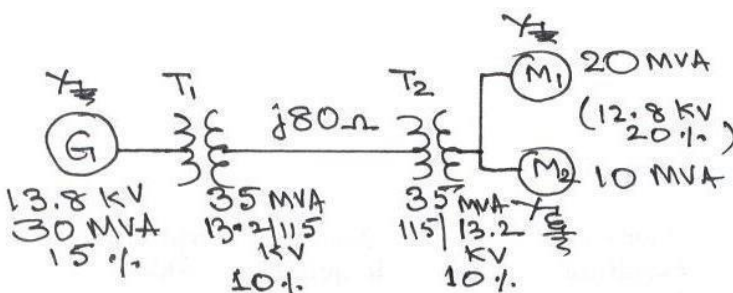


**Problem #3:**

A 30 MVA, 13.8 KV, 3-phase generator has a sub transient reactance of 15%. The generator supplies 2 motors through a step-up transformer - transmission line – step down transformer arrangement. The motors have rated inputs of 20 MVA and 10 MVA at 12.8 KV with 20% sub transient reactance each. The 3-phase transformers are rated at 35 MVA, 13.2 KV-□□/115 KV-Y with 10 % leakage reactance. The line reactance is 80 ohms. Draw the equivalent per unit reactance diagram by selecting the generator ratings as base values in the generator circuit.

**Solution:**

The one line diagram with the data is obtained as shown in figure P3



Selection of base quantities:

**30 MVA, 13.8 KV** in the generator circuit (Given);

The voltage bases in other sections are:

13.8 (115/13.2) = **120.23 KV** in the transmission line circuit and

120.23 (13.26/115) = **13.8 KV** in the motor circuit.

Calculation of pu values:

$$X_G = j 0.15 \text{ pu.}$$

$$X_{m1} = j 0.2 (30/20) (12.8/13.8)^2 = j 0.516 \text{ pu.}$$

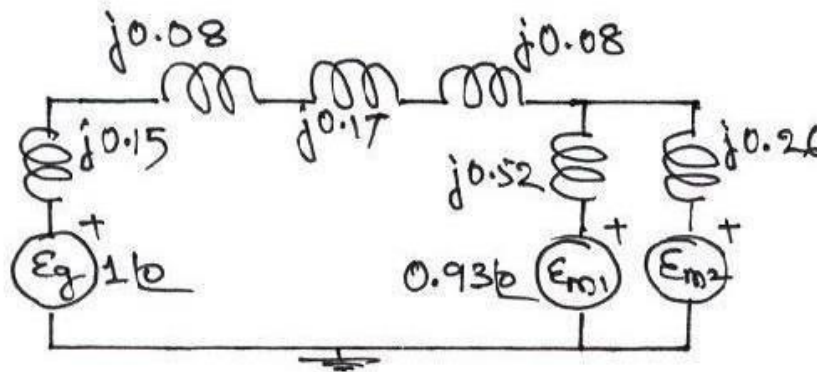
$$X_{m2} = j 0.2 (30/10) (12.8/13.8)^2 = j 0.2581 \text{ pu.}$$

$$X_{t1} = X_{t2} = j 0.1 (30/35) (13.2/13.8)^2 = j 0.0784 \text{ pu.}$$

$$X_{line} = j 80 (30/120.23^2) = j 0.17 \text{ pu.}$$

$E_g = 1.0 \angle 0$  pu;  $E_{m1} = E_{m2} = (6.6/6.31) = 0.93 \angle 0$  pu

Thus the pu reactance diagram can be drawn as shown in figure P3



**Problem #4:**

A 33 MVA, 13.8 KV, 3-phase generator has a sub transient reactance of 0.5%. The generator supplies a motor through a step-up transformer - transmission line – step-down transformer arrangement. The motor has rated input of 25 MVA at 6.6 KV with 25% sub transient reactance. Draw the equivalent per unit impedance diagram by selecting 25 MVA (3 $\phi$ ), 6.6 KV (LL) as base values in the motor circuit, given the transformer and transmission line data as under:

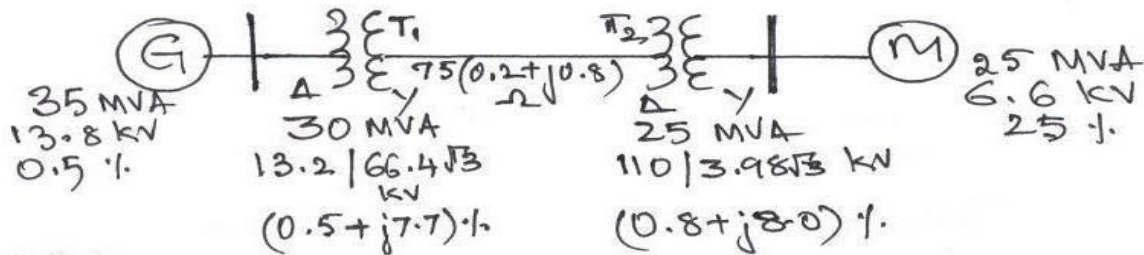
Step up transformer bank: three single phase units, connected  $\Delta$ -Y, each rated 10 MVA, 13.2/6.6 KV with 7.7 % leakage reactance and 0.5 % leakage resistance;

Transmission line: 75 KM long with a positive sequence reactance of 0.8 ohm/ KM and a resistance of 0.2 ohm/ KM; and

Step down transformer bank: three single phase units, connected  $\Delta$ -Y, each rated 8.33 MVA, 110/3.98 KV with 8% leakage reactance and 0.8 % leakage resistance;

**Solution:**

The one line diagram with the data is obtained as shown in figure P4



**3-phase ratings of transformers:**

T1: 3(10) = 30 MVA, 13.2/ 66.4 $\sqrt{3}$  KV = 13.2/ 115 KV, X = 0.077, R = 0.005 pu.

T2: 3(8.33) = 25 MVA, 110/ 3.98 $\sqrt{3}$  KV = 110/ 6.8936 KV, X = 0.08, R = 0.008 pu.

Selection of base quantities:

25 MVA, 6.6 KV in the motor circuit (Given); the voltage bases in other sections are: 6.6 (110/6.8936) = **105.316** KV in the transmission line circuit and 105.316 (13.2/115) = **12.09** KV in the generator circuit.

Calculation of pu values:

$X_m = j 0.25$  pu;  $E_m = 1.0 \angle 0$  pu.

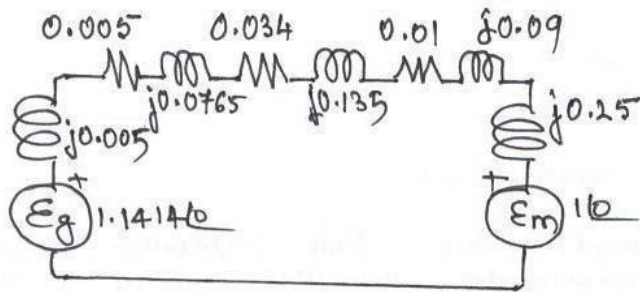
$X_G = j 0.005 (25/33) (13.8/12.09)^2 = j 0.005$  pu;  $E_g = 13.8/12.09 = 1.414 \angle 0$  pu.

$Z_{t1} = 0.005 + j 0.077 (25/30) (13.2/12.09)^2 = 0.005 + j 0.0765$  pu. (ref. to LV side)

$Z_{t2} = 0.008 + j 0.08 (25/25) (110/105.316)^2 = 0.0087 + j 0.0873$  pu. (ref. to HV side)

$Z_{line} = 75 (0.2+j 0.8) (25/ 105.316^2) = 0.0338 + j 0.1351$  pu.

Thus the pu reactance diagram can be drawn as shown in figure



### 1.13. Exercises for Practice

#### Problems

1. Determine the reactances of the three generators rated as follows on a common base of 200 MVA, 35 KV: Generator 1: 100 MVA, 33 KV, sub transient reactance of 10%; Generator 2: 150 MVA, 32 KV, sub transient reactance of 8% and Generator 3: 110 MVA, 30 KV, sub transient reactance of 12%.

[Answers:  $X_{G1} = j 0.1778$ ,  $X_{G2} = j 0.089$ ,  $X_{G3} = j 0.16$  all in per unit]

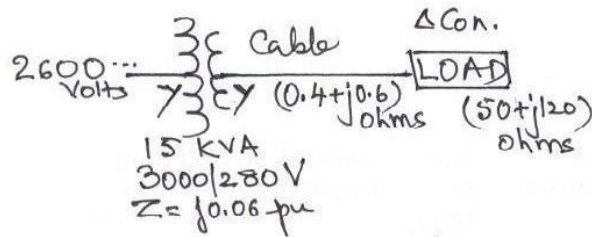
2. A 100 MVA, 33 KV, 3-phase generator has a sub transient reactance of 15%. The generator supplies 3 motors through a step-up transformer - transmission line - step down transformer arrangement. The motors have rated inputs of 30 MVA, 20 MVA and 50 MVA, at 30 KV with 20% sub transient reactance each. The 3-phase transformers are rated at 100 MVA, 32 KV-□□/110 KV-Y with 8 % leakage reactance. The line has a reactance of 50 ohms. By selecting the generator ratings as base values in the generator circuit, determine the base values in all the other parts of the system. Hence evaluate the corresponding pu values and draw the equivalent per unit reactance diagram.

[Answers:  $X_G = j 0.15$ ,  $X_{m1} = j 0.551$ ,  $X_{m2} = j 0.826$ ,  $X_{m3} = j 0.331$ ,  $E_{g1} = 1.0 \angle 0^\circ$ ,  $E_{m1} = E_{m2} = E_{m3} = 0.91 \angle 0^\circ$ ,  $X_{t1} = X_{t2} = j 0.0775$  and  $X_{line} = j 0.39$  all in per unit]

3. A 80 MVA, 10 KV, 3-phase generator has a sub transient reactance of 10%. The generator supplies a motor through a step-up transformer - transmission line - step-down transformer arrangement. The motor has rated input of 95 MVA, 6.3 KV with 15% sub transient reactance. The step-up 3-phase transformer is rated at 90 MVA, 11 KV-Y /110 KV-Y with 10% leakage reactance. The 3-phase step-down transformer consists of three single phase Y-□□connected transformers, each rated at 33.33 MVA, 68/6.6 KV with 10% leakage reactance. The line has a reactance of 20 ohms. By selecting the 11 KV, 100 MVA as base values in the generator circuit, determine the base values in all the other parts of the system. Hence evaluate the corresponding pu values and draw the equivalent per unit reactance diagram.

[Answers:  $X_G = j 1.103$ ,  $X_m = j 0.165$ ,  $E_{g1} = 0.91 \angle 0^\circ$ ,  $E_m = 1.022 \angle 0^\circ$ ,  $X_{t1} = j 0.11$ ,  $X_{t2} = j 0.114$  and  $X_{line} = j 0.17$  all in per unit]

4. For the three-phase system shown below, draw an impedance diagram expressing all impedances in per unit on a common base of 20 MVA, 2600 V on the HV side of the transformer. Using this impedance diagram, find the HV and LV currents.



[Answers:  $S_b = 20$  MVA;  $V_b = 2.6$  KV (HV) and  $0.2427$  KV (LV);  $V_t = 1.0 \times 100$ ,  $X_t = j 0.107$ ,  $Z_{\text{cable}} = 0.136 + j 0.204$  and  $Z_{\text{load}} = 5.66 + j 2.26$ ,  $I = 0.158$  all in per unit,  $I_{(hv)} = 0.7$  A and  $I_{(lv)} = 7.5$  A]



## UNIT II      POWER FLOW ANALYSIS

### IMPORTANCE OF POWER FLOW ANALYSIS IN PLANNING AND OPERATION OF POWER SYSTEMS.

#### POWER FLOW STUDY OR LOAD FLOW STUDY

The study of various methods of solution to power system network is referred to as load flow study. The solution provides the voltages at various buses, power flowing in various lines and line losses.

#### Information's that are obtained from a load flow study

The information obtained from a load flow study is magnitude and phase angle of voltages, real and reactive power flowing in each line and the line losses. The load flow solution also gives the initial conditions of the system when the transient behavior of the system is to be studied.

#### Need for load flow study

The load flow study of a power system is essential to decide the best operation of existing system and for planning the future expansion of the system. It is also essential for designing a new power system.

### STATEMENT OF POWER FLOW PROBLEM

#### Quantities associated with each bus in a system

Each bus in a power system is associated with four quantities and they are real power (P), reactive power (Q), magnitude of voltage (V), and phase angle of voltage ( $\delta$ ).

#### Work involved (or) to be performed by a load flow study

- (i). Representation of the system by a single line diagram
- (ii). Determining the impedance diagram using the information in single line diagram
- (iii). Formulation of network equation
- (iv). Solution of network equations

#### Iterative methods to solve load flow problems

The load flow equations are non linear algebraic equations and so explicit solution as not possible. The solution of non linear equations can be obtained only by iterative numerical techniques.

#### Mainly used for solution of load flow study

The Gauss seidal method, Newton Raphson method and Fast decouple methods.

#### Flat voltage start

In iterative method of load flow solution, the initial voltages of all buses except slack bus assumed as  $1+j0$  p.u. This is referred to as flat voltage start

### CLASSIFICATION OF BUSES

#### Bus

The meeting point of various components in a power system is called a bus. The bus is a conductor made of copper or aluminum having negligible resistance. At some of the buses power is being injected into the network, whereas at other buses it is being tapped by the system loads.

#### Bus admittance matrix

The matrix consisting of the self and mutual admittance of the network of the power system is called bus admittance matrix ( $Y_{bus}$ ).

#### Methods available for forming bus admittance matrix

Direct inspection method.

Singular transformation method.(Primitive network)

#### Different types of buses in a power system

Types of bus	Known or specified quantities	Unknown quantities or quantities to be determined
Slack or Swing or Reference bus	V, $\delta$	P, Q
Generator or Voltage control or PV bus	P, V	Q, $\delta$
Load or PQ bus	P, Q	V, $\delta$

### Need for slack bus

The slack bus is needed to account for transmission line losses. In a power system the total power generated will be equal to sum of power consumed by loads and losses. In a power system only the generated power and load power are specified for buses. The slack bus is assumed to generate the power required for losses. Since the losses are unknown the real and reactive power are not specified for slack bus.

### Effect of acceleration factor in load flow study

Acceleration factor is used in gauss seidal method of load flow solution to increase the rate of convergence. Best value of A.F=1.6

### Generator buses are treated as load bus

If the reactive power constraint of a generator bus violates the specified limits then the generator is treated as load bus.

## ITERATIVE SOLUTION USING GAUSS-SEIDEL METHOD - ALGORITHM

### Algorithm of Gauss seidal method

**Step1:** Assume all bus voltage be  $1 + j0$  except slack bus. The voltage of the slack bus is a constant voltage and it is not modified at any iteration

**Step 2:** Assume a suitable value for specified change in bus voltage which is used to compare the actual change in bus voltage between  $K^{th}$  and  $(K+1)^{th}$  iteration

**Step 3:** Set iteration count  $K = 0$  and the corresponding voltages are  $V_1^0, V_2^0, V_3^0, \dots, V_n^0$  except slack bus

**Step 4:** Set bus count  $P = 1$

**Step 5:** Check for slack bus. It is a slack bus then goes to step 12 otherwise go to next step

**Step 6:** Check for generator bus. If it is a generator bus go to next step. Otherwise go to

**Step 7:** Set  $|V_P^K| = |V_P^0|$  specified and phase of  $|V_P^K|$  as the  $K^{th}$  iteration value if the bus P is a generator bus where  $|V_P^0|$  specified is the specified magnitude of voltage for bus P. Calculate reactive power rating

n

$$Q_P^{K+1} \text{ Cal} = (-1) \text{ Imag} [(V_P^K)^A (\sum_{q=1} Y_{pq} V_q^{K+1} + \sum_{q=P} Y_{pq} V_q^K)$$

**Step 8:** If calculated reactive power is within the specified limits then consider the bus as generator bus and then set  $Q_P = Q_P^{K+1} \text{ Cal}$  for this iteration go to step 10

**Step 9 :** If the calculated reactive power violates the specified limit for reactive power then treat this bus as load bus

If  $Q_P^{K+1} \text{ Cal} < Q_{P \text{ min}}$  then  $Q_P = Q_{P \text{ min}}$

$Q_P^{K+1} \text{ Cal} > Q_{P \text{ max}}$  then  $Q_P = Q_{P \text{ max}}$

**Step10:** For generator bus the magnitude of voltage does not change and so for all iterations the magnitude of bus voltage is the specified value. The phase of the bus voltage can be calculated using

**Step 11:** For load bus the  $(k+1)$ th iteration value of load bus P voltage  $V_P^{K+1}$  can be calculated using  $V_P^{K+1} = 1 / Y_{PP} [(P-jQ_P / V_P^{K*}) - \sum Y_{pq} V_q^{K+1} - \sum Y_{pq} V_q^K]$

**Step 12:** An acceleration factor  $\alpha$  can be used for faster convergence. If acceleration factor  $\alpha$  is specified then modify the  $(K+1)$ th iteration value of bus P using  $V_{Pacc}^{K+1} = V_P^{K+1} + \alpha (V_P^{K+1} - V_P^K)$  then Set  $V_P^{K+1} = V_{Pacc}^{K+1}$

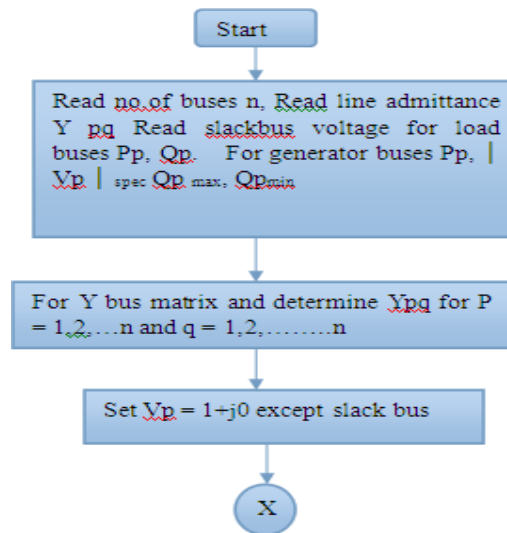
**Step 13:** Calculate the change in bus-P voltage using the relation  $\Delta V_P^{K+1} = V_P^{K+1} - V_P^K$

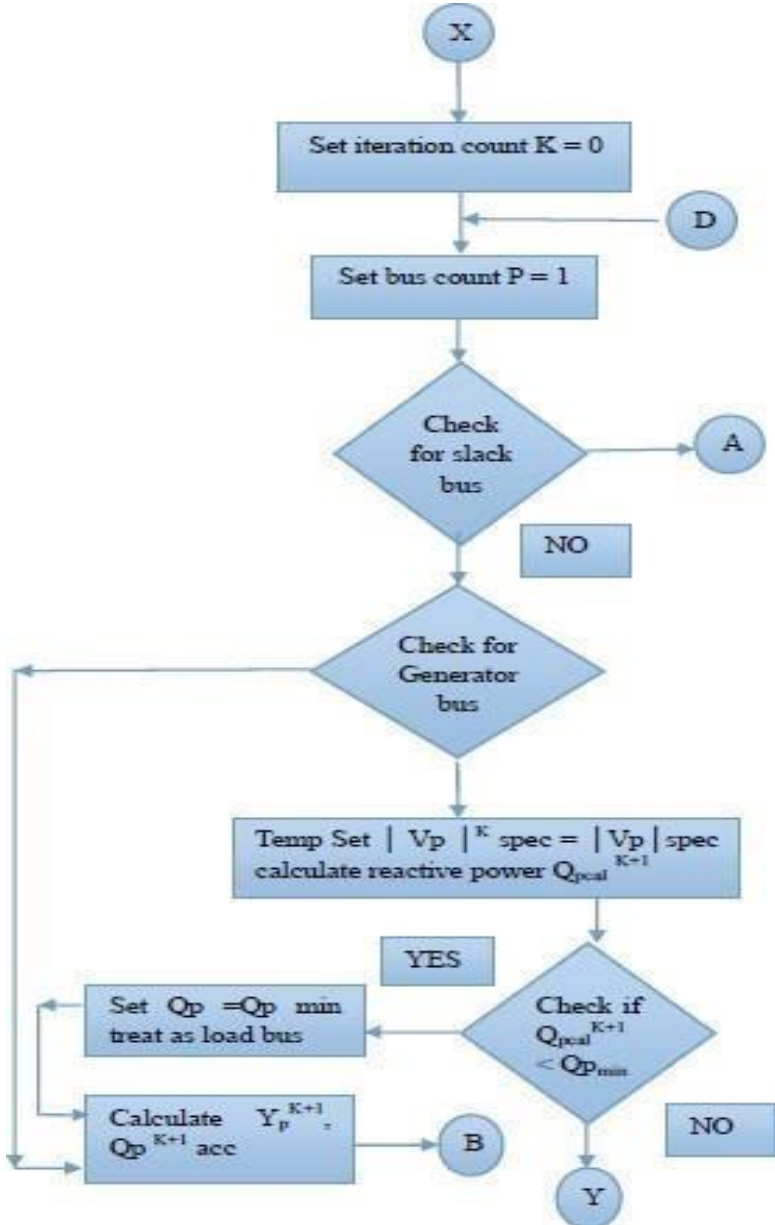
**Step 14:** Repeat step 5 to 12 until all the bus voltages have been calculated. For this increment the bus count by 1 go to step 5 until the bus count is n

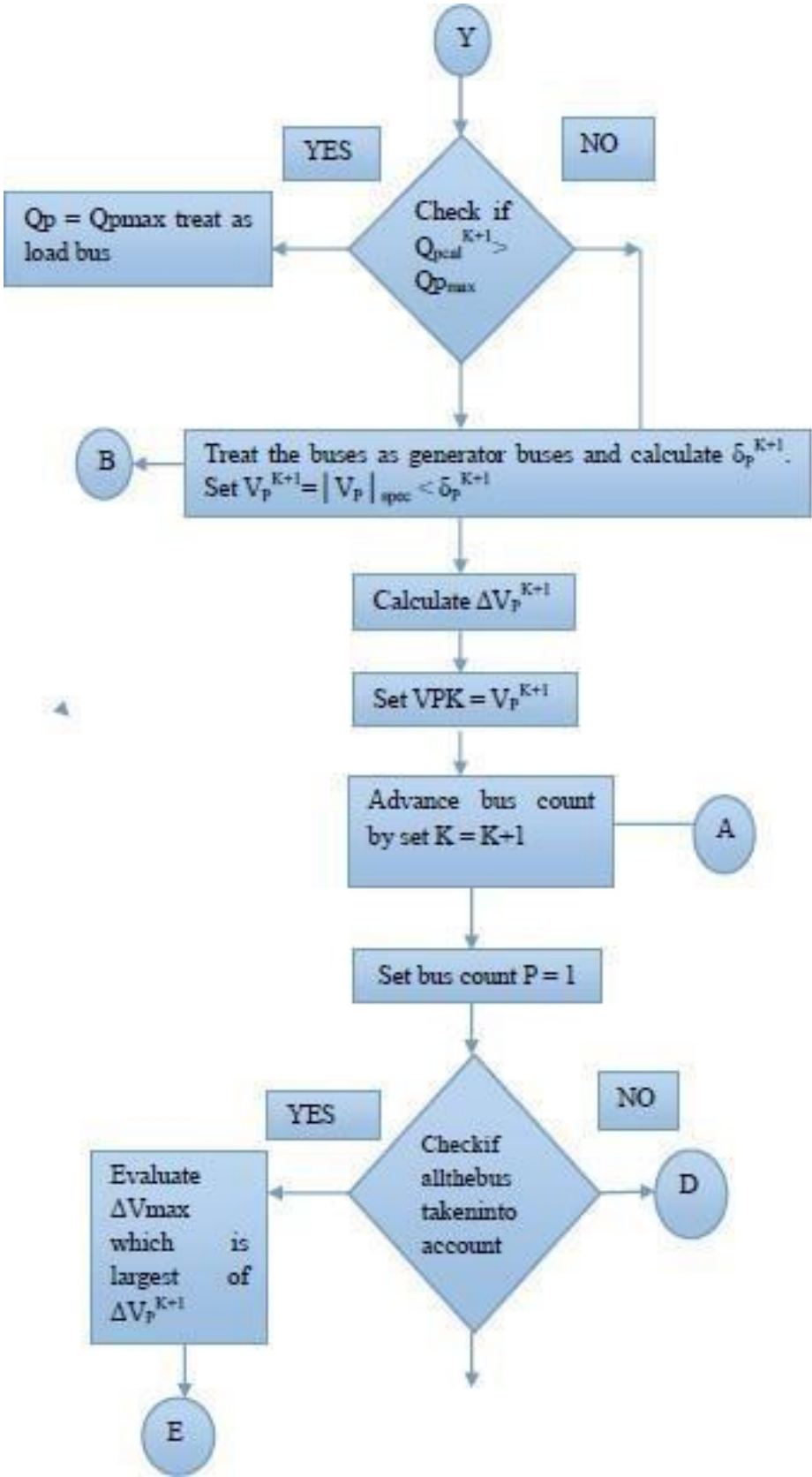
**Step 15:** Find the largest of the absolute value of the change in voltage  $|\Delta V_1^{K+1}|, |\Delta V_2^{K+1}|, |\Delta V_3^{K+1}|, \dots, |\Delta V_n^{K+1}|$   
 Let this largest value be the  $|\Delta V_{max}|$ . Check this largest change  $|\Delta V_{max}|$  is less than pre specified tolerance. If  $|\Delta V_{max}|$  is less go to next step. Otherwise increment the iteration count and go to step 4

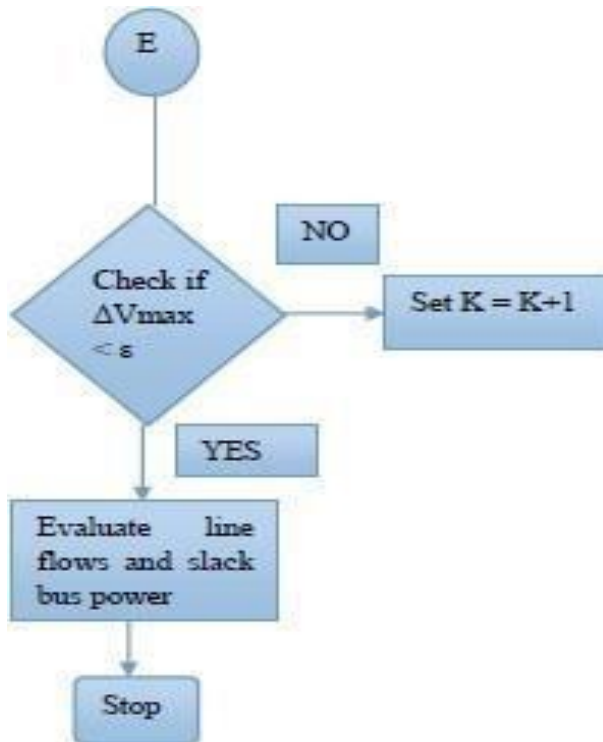
**Step 16:** Calculate the line flows and slack bus power by using the bus voltages

**Gauss - Seidal method flow chart**









### ITERATIVE SOLUTION USING NEWTON-RAPHSON METHOD – ALGORITHM

**Step 1:** Assume a suitable solution for all buses except the slack bus. Let  $V_p = a+j0$  for  $P = 2,3,\dots,n$   $V_1 = a+j0$

**Step 2 :** Set the convergence criterion =  $\epsilon 0$

**Step 3 :** Set iteration count  $K= 0$

**Step 4 :** Set bus count  $P = 2$

**Step 5 :** Calculate  $P_p$  and  $Q_p$  using

$$P_p = \sum_{q=1}^n \{ e_p(e_p G_{pq} + f_p B_{qp}) + f_p(f_p G_{pq} - e_p B_{pq}) \}$$

$$Q_p = \sum_{q=1}^n \{ f_p(e_p G_{pq} + f_p B_{qp}) + e_p(f_p G_{pq} - e_p B_{pq}) \}$$

**Step 6 :** Evaluate  $\Delta P_p^K = P_{spec} - P_p^K$

**Step 7 :** Check if the bus is the question is a PV bus. If yes compare  $Q_p^K$  with the limits. If it exceeds the limit fix the Q value to the corresponding limit and treat the bus as PQ for that iteration and go to next step (or) if the lower limit is not violated evaluate  $|\Delta V_p|^2 = |V_{spec}|^2 - |V_p^K|^2$  and go to step 9

**Step 8:** Evaluate  $\Delta Q_p^K = Q_{spec} - Q_p^K$

**Step 9 :** Advance bus count  $P = P+1$  and check if all buses taken in to account if not go to step 5

**Step 10 :** Determine the largest value of  $|\Delta V_P|^2$

**Step 11:** If  $\Delta V_P < \epsilon$  go to step 16

**Step 12:** Evaluate the element of Jacobin matrices  $J_1, J_2, J_3, J_4, J_5$  and  $J_6$

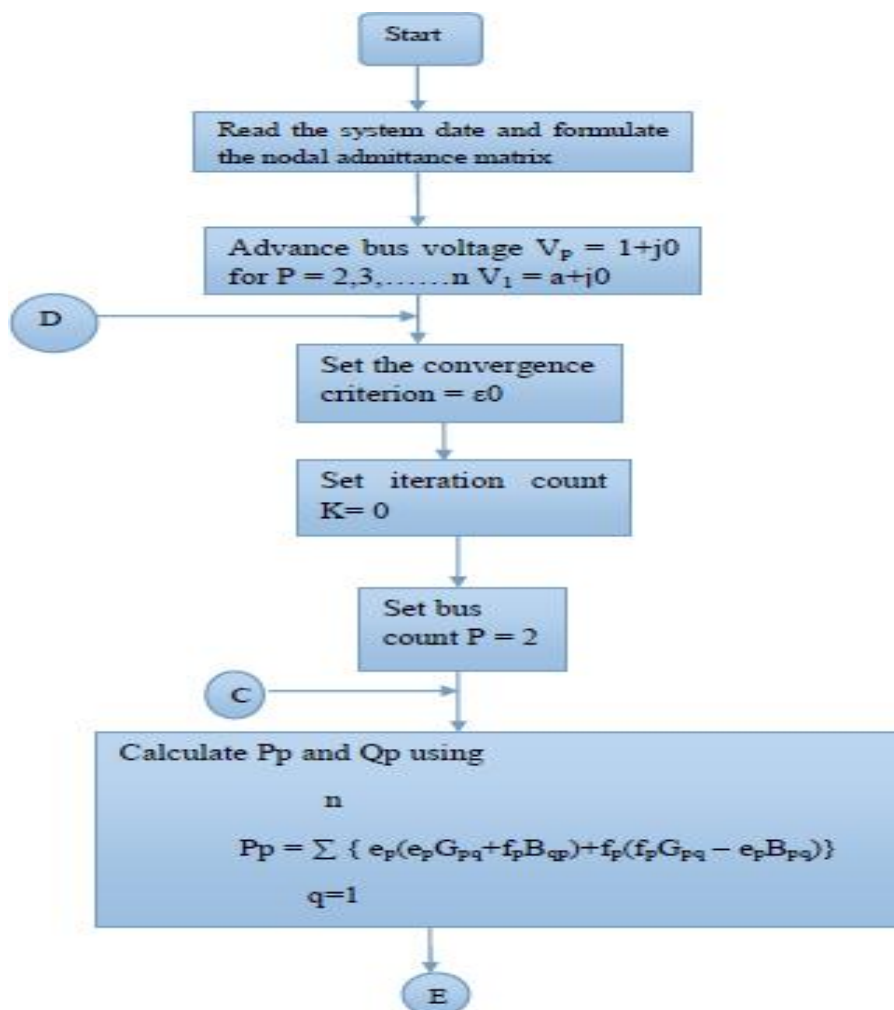
**Step 13:** Calculate  $\Delta e_P^K$  and  $\Delta f_P^K$

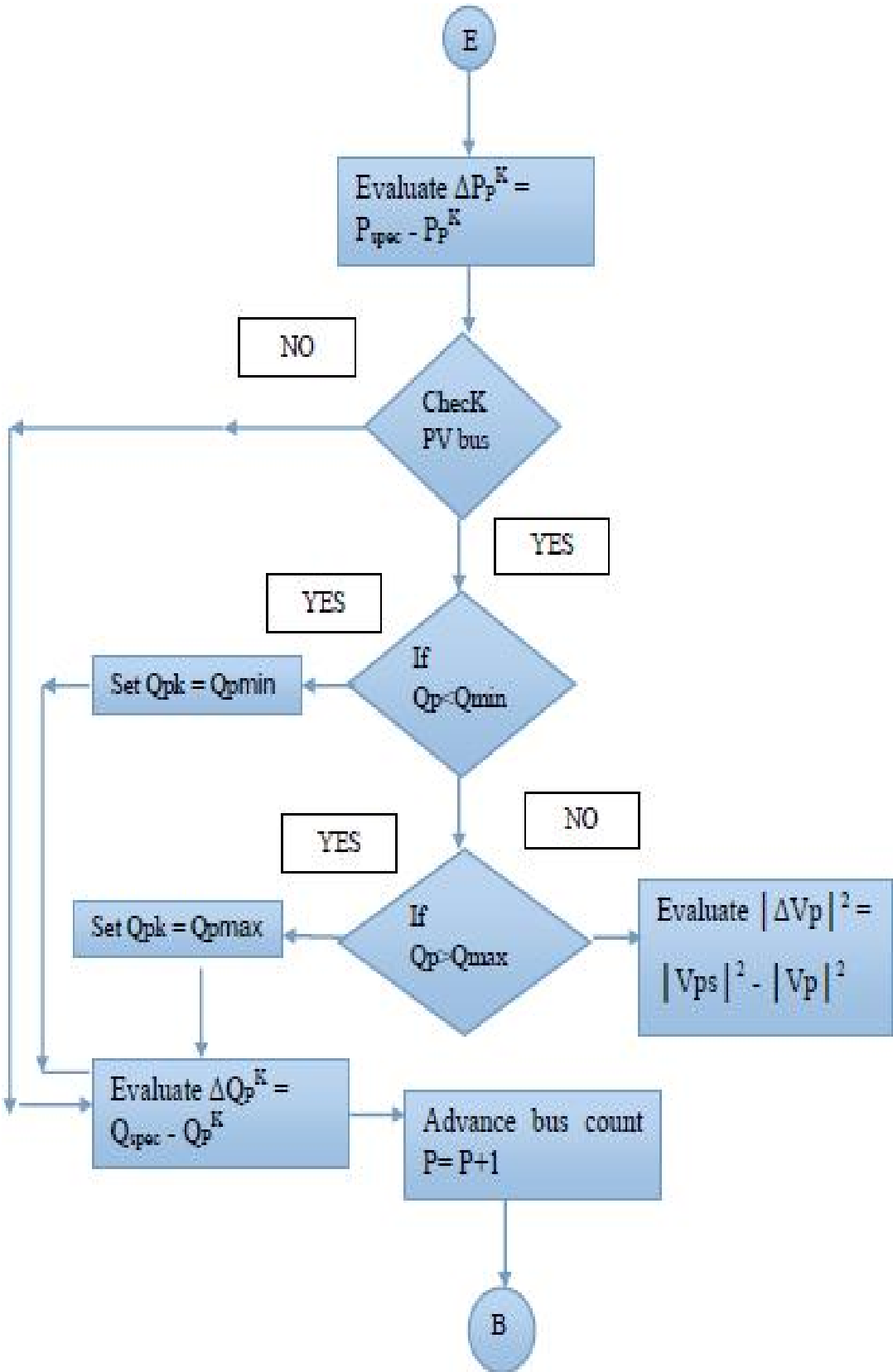
**Step 14:** Calculate  $e_P^{K+1} = e_P^K + \Delta e_P^K$  and  $f_P^{K+1} = f_P^K + \Delta f_P^K$

**Step 15 :** Advance count (iteration)  $K=K+1$  and go to step 4

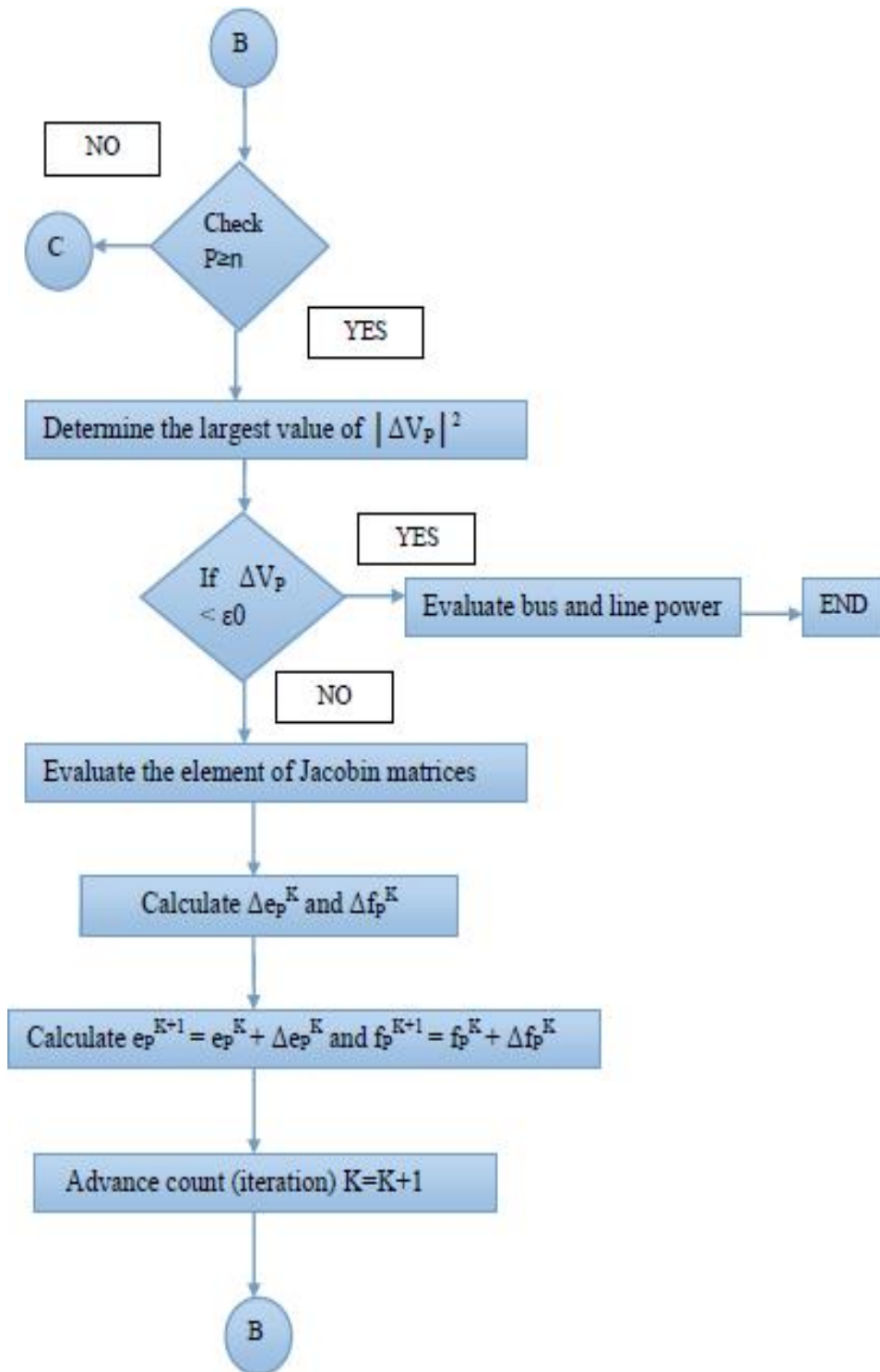
**Step 16:** Evaluate bus and line power and print the result

**Iterative solution using Newton-Raphson method – Flow chart**









### ITERATIVE SOLUTION USING FAST DECOUPLED LOAD FLOW METHOD – ALGORITHM

**Step 1:** Assume a suitable solution for all buses except the slack bus. Let  $V_p = 1 + j0$  for  $P = 2, 3, \dots, n$  and  $V = a + j0$

**Step 2:** Set the convergence criterion  $= \epsilon_0$

**Step 3:** Set iteration count  $K = 0$

**Step 4:** Set bus count  $P = 2$

**Step 5:** Calculate  $P_p$  and  $Q_p$  using

$$P_p = \sum_{q=1}^n |V_p V_q Y_{pq}| \cos(\theta_{pq} + \delta_p - \delta_q)$$

$$Q_p = \sum_{q=1}^n |V_p V_q Y_{pq}| \sin(\theta_{pq} + \delta_p - \delta_q)$$

**Step 6:** Compute the real and reactive power mismatches  $\Delta P^K$  and  $\Delta Q^K$ . If the mismatches are within a desirable tolerance the iteration ends

**Step 7:** Normalize the mismatches by dividing each entry by its respective bus voltage

$$\Delta P^K = \begin{bmatrix} \Delta P_2^K / V_2^K \\ \Delta P_3^K / V_3^K \\ \vdots \\ \Delta P_n^K / V_n^K \end{bmatrix}$$

$$\Delta Q^K = \begin{bmatrix} \Delta Q_2^K / V_2^K \\ \Delta Q_3^K / V_3^K \\ \vdots \\ \Delta Q_n^K / V_n^K \end{bmatrix}$$

**Step 8:** Solve for the voltage magnitude and the correction factors  $\Delta V^K$  and  $\Delta \delta^K$  by using the constant matrices  $B'$  and  $B''$  which are extracted from the bus admittance matrix  $Y_{Bus}$

$$[B'] \Delta \delta^K = \Delta P^K$$

$$[B''] \Delta Q^K = \Delta Q^K$$

**Step 9:** Update the voltage magnitude and angle vectors

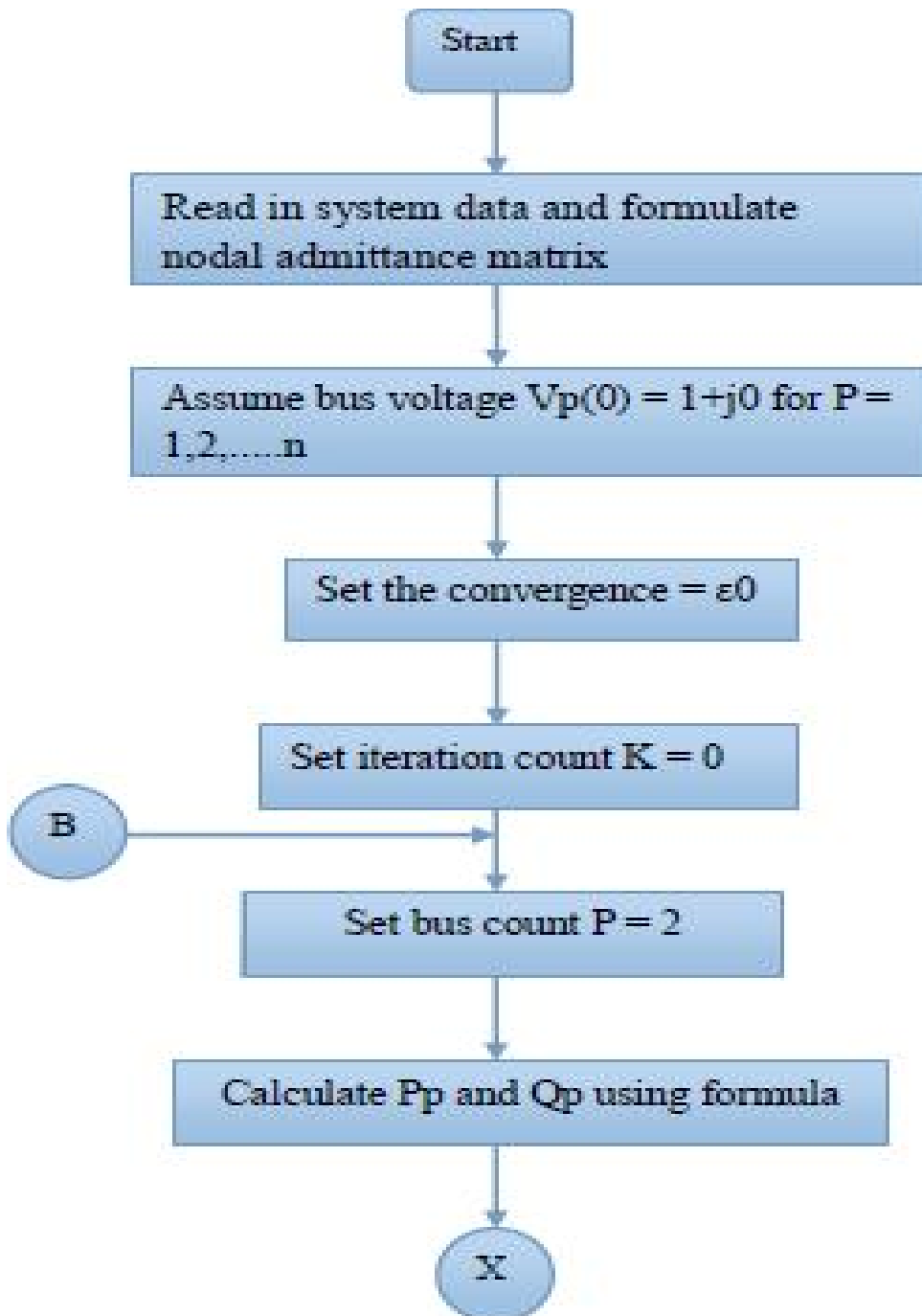
$$\delta^{K+1} = \delta^K + \Delta \delta^K$$

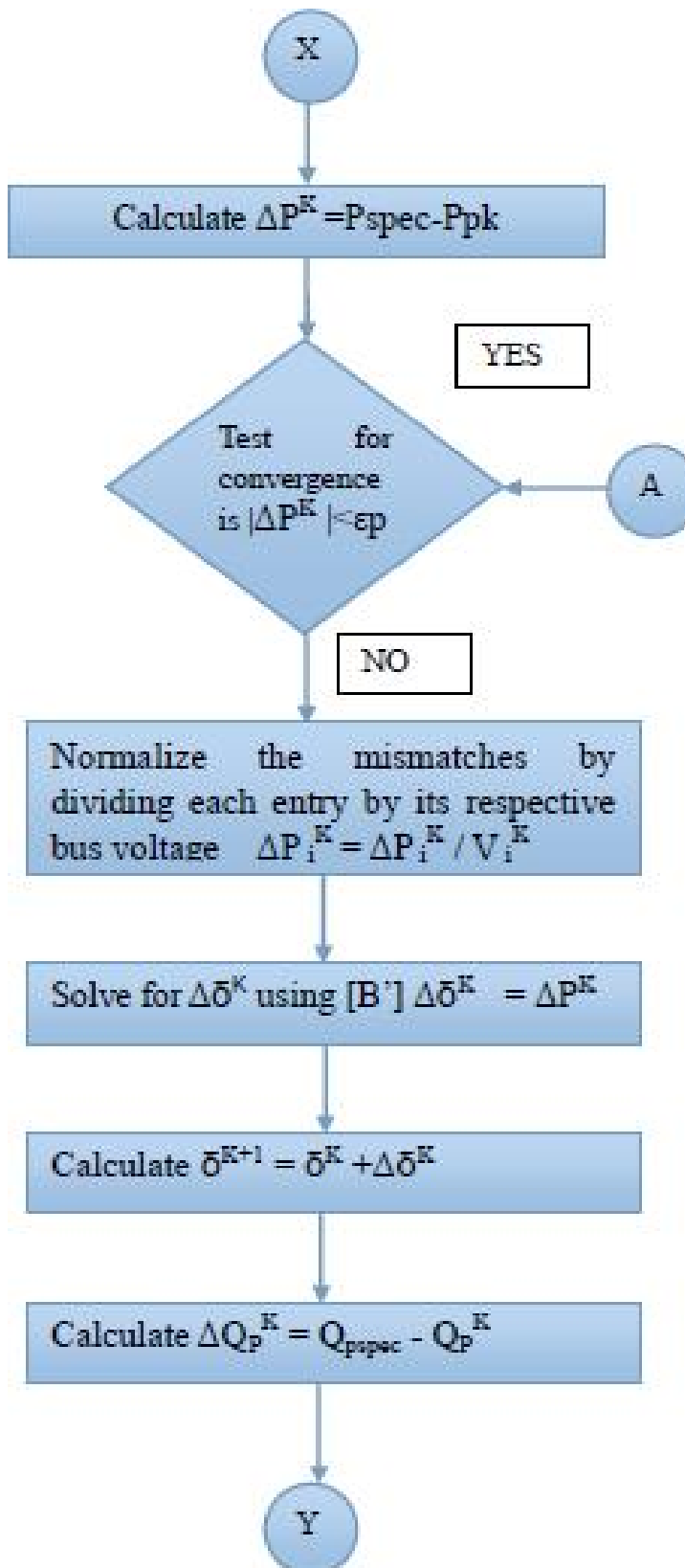
$$V^{K+1} = V^K + \Delta V^K$$

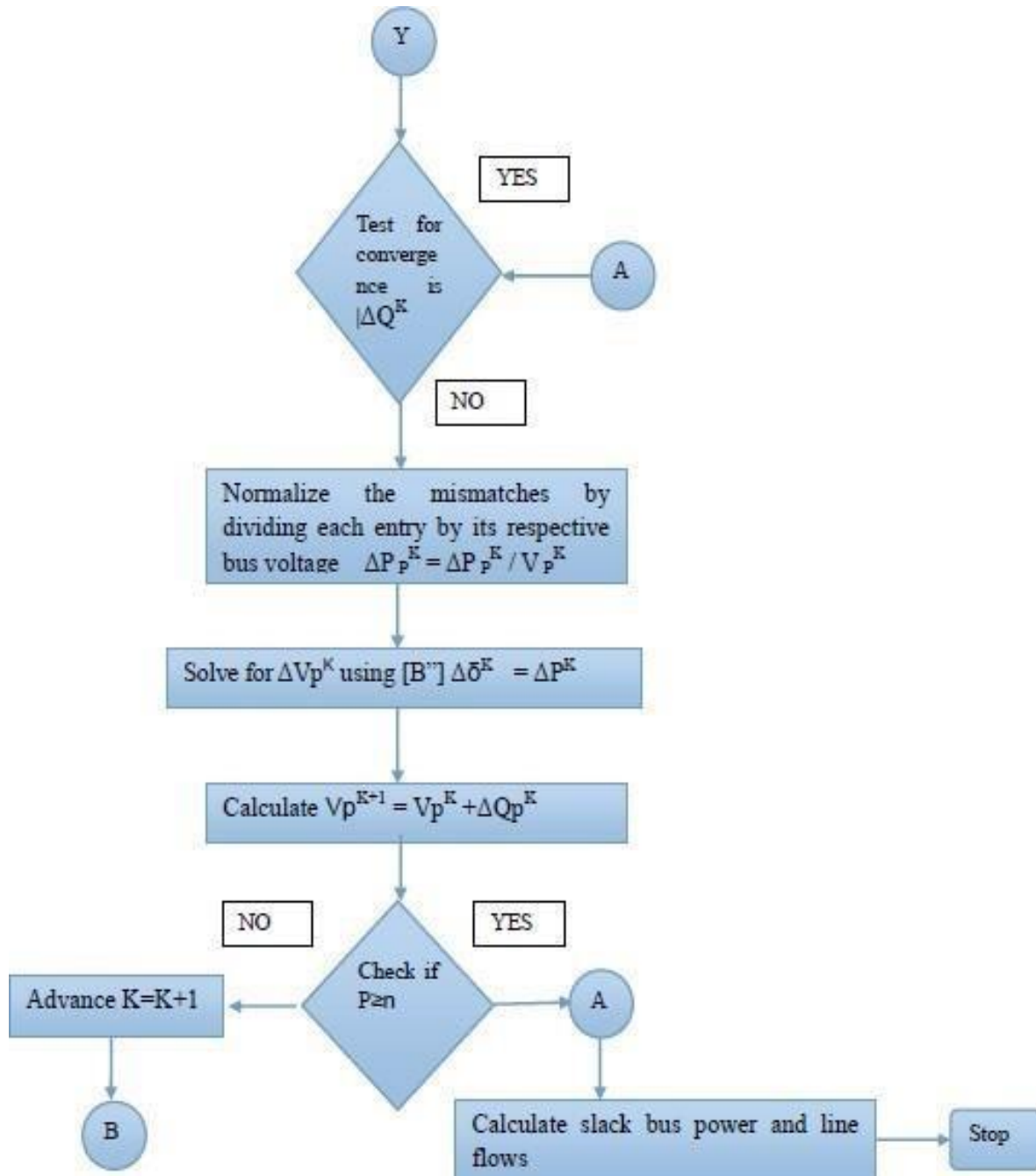
**Step 10:** Check if all the buses are taken into account if yes go to next step otherwise go to next step. Otherwise go to step 4

**Step 11:** Advance iteration count  $K = K+1$  go to step 3

**Step 12:** Evaluate bus and load powers and print the results







### ITERATIVE SOLUTION USING FAST DECOUPLED LOAD FLOW METHOD – FLOW CHART

#### Advantages and disadvantages of Gauss-Seidel method

**Advantages:** Calculations are simple and so the programming task is less. The memory requirement is less. Useful for small systems;

**Disadvantages:** Requires large no. of iterations to reach convergence. Not suitable for large systems. Convergence time increases with size of the system

#### Advantages and disadvantages of N.R method

**Advantages:** Faster, more reliable and results are accurate, require less number of iterations;

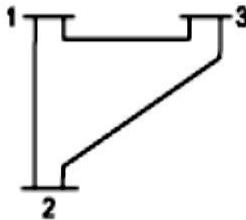
**Disadvantages:** Program is more complex, memory is more complex.

### COMPARE THE GAUSS SEIDEL AND NEWTON RAPHSON METHODS OF LOAD FLOW STUDY

S.No	G.S	N.R	FDLF
1	Require large number of iterations to reach convergence	Require less number of iterations to reach convergence.	Require more number of iterations than N.R method
2	Computation time per iteration is less	Computation time per iteration is more	Computation time per iteration is less
3	It has linear convergence characteristics	It has quadratic convergence characteristics	....
4	The number of iterations required for convergence increases with size of the system	The number of iterations are independent of the size of the system	The number of iterations are does not dependent of the size of the system
5	Less memory requirements	More memory requirements.	Less memory requirements than N.R.method.

Y matrix of the sample power system as shown in fig. Data for this system is given in table.

Bus code <i>i-k</i>	Impedance $Z_{ik}$	Line charging $y_{i k2}$
1-2	$0.02 + j0.06$	$j0.03$
1-3	$0.08 + j0.24$	$j0.025$
2-3	$0.06 + j0.18$	$j0.020$



### UNIT III FAULT ANALYSIS – BALANCED FAULTS

#### IMPORTANCE SHORT CIRCUIT (OR) FOR FAULT ANALYSIS

##### **Fault**

A fault in a circuit is any failure which interferes with the normal flow of current. The faults are associated with abnormal change in current, voltage and frequency of the power system.

##### **Faults occur in a power system**

The faults occur in a power system due to

- (i). Insulation failure of equipment
- (ii). Flashover of lines initiated by a lighting stroke
- (iii). Due to permanent damage to conductors and towers or due to accidental faulty operations.

##### **Various types of faults**

- (i) Series fault or open circuit fault

One open conductor fault

Two open conductor fault

- (ii) Shunt fault or short circuit fault.

Symmetrical fault or balanced fault

- Three phase fault

Unsymmetrical fault or unbalanced fault

- Line to ground (L-G) fault
- Line to Line (L-L) fault
- Double line to ground (L-L-G) fault

##### **Relative frequency of occurrence of various types of fault**

Types of fault	Relative frequency of occurrence of faults
Three phase fault	5%
Double line to ground fault	10%
Line to Line fault	15%
Line to ground fault	70%

##### **Symmetrical fault or balanced three phase fault**

This type of fault is defined as the simultaneous short circuit across all the three phases. It occurs infrequently, but it is the most severe type of fault encountered. Because the network is balanced, it is solved by per phase basis using Thevenins theorem or bus impedance matrix or KVL, KCL laws.

#### **BASIC ASSUMPTIONS IN FAULT ANALYSIS OF POWER SYSTEMS.**

- (i). Representing each machine by a constant voltage source behind proper reactance which may be  $X''$ ,  $X'$ , or  $X$
- (ii). Pre-fault load current are neglected
- (iii). Transformer taps are assumed to be nominal
- (iv). Shunt elements in the transformers model that account for magnetizing current and core loss are neglected
- (v). A symmetric three phase power system is conducted
- (vi). Shunt capacitance and series resistance in transmission are neglected

(vii). The negative sequence impedances of alternators are assumed to be the same as their positive sequence impedance  $Z^+ = Z^-$

#### **Need for short circuit studies or fault analysis**

Short circuit studies are essential in order to design or develop the protective schemes for various parts of the system. To estimate the magnitude of fault current for the proper choice of circuit breaker and protective relays.

#### **Bolted fault or solid fault**

A Fault represents a structural network change equivalent with that caused by the addition of impedance at the place of a fault. If the fault impedance is zero, the fault is referred as bolted fault or solid fault.

#### **Reason for transients during short circuits**

The faults or short circuits are associated with sudden change in currents. Most of the components of the power system have inductive property which opposes any sudden change in currents, so the faults are associated with transients.

#### **Doubling effect**

If a symmetrical fault occurs when the voltage wave is going through zero then the maximum momentary short circuit current will be double the value of maximum symmetrical short circuit current. This effect is called doubling effect.

#### **DC offset current**

The unidirectional transient component of short circuit current is called DC offset current.

### **SYMMETRICAL FAULT**

In symmetrical faults all the three phases are short circuited to each other and to earth also. Such faults are balanced and symmetrical in the sense that the voltage and current of the system remains balanced even after the fault and it is enough if we consider any one phase

#### **Short circuit capacity of power system or fault level.**

Short circuit capacity (SCC) or Short circuit MVA or fault level at a bus is defined as the product of the magnitude of the pre fault bus voltage and the post fault current

$$\text{SCC or Short circuit MVA} = |V_{\text{prefault}}| \times |I_f|$$

(OR)

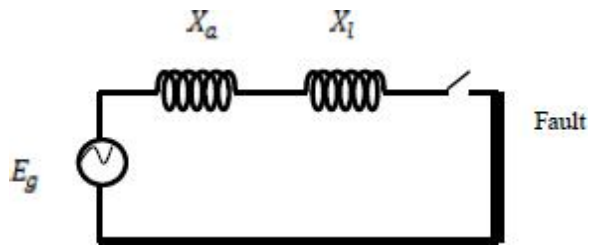
$$\text{SCC} = \frac{1}{x_{th}} \text{ p.u MVA}$$

#### **Synchronous reactance or steady state condition reactance**

The synchronous reactance is the ratio of induced emf and the steady state rms current. It is the sum of leakage reactance ( $X_l$ ) and the armature reactance ( $X_a$ ).

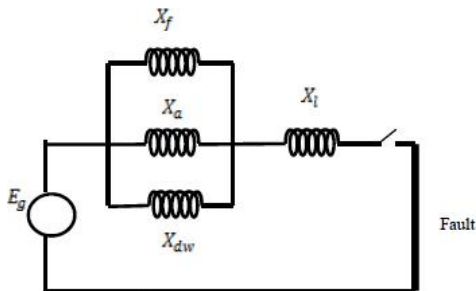
$$X_d = X_a + X_l$$





**Sub transient reactance**

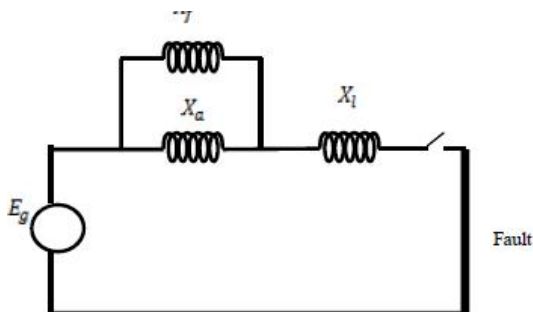
The synchronous reactance is the ratio of induced emf on no load and the sub transient symmetrical rms current.



$$X''_d = X_l + \frac{1}{\frac{1}{X_a} + \frac{1}{X_f} + \frac{1}{X_{dw}}}$$

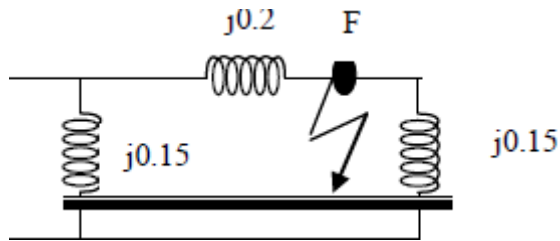
**Transient reactance**

The synchronous reactance is the ratio of induced emf on no load and the transient symmetrical rms current.



$$X'_d = X_l + \frac{1}{\frac{1}{X_a} + \frac{1}{X_f}}$$

**Fault current in fig., if the Pre-fault voltage at the fault point is 0.97 p.u.**

**Thevenin's theorem:**

- (i). Fault current =  $E_{th} / (Z_{th} + Z_f)$
- (ii). Determine current contributed by the two generators  $I_{G1} = I_f * (Z_2 / (Z_1 + Z_2))$   
 $I_{G2} = I_f * (Z_1 / (Z_1 + Z_2))$
- (iii). Determine Post fault voltage  $V_{if} = V_i^o + \Delta V = V^o + (-Z_{i2} * I_{G_i})$
- (iv). Determine post fault voltage line flows  $I_{ij} = (V_i - V_j) / Z_{ij}$  series
- (v). Short circuit capacity  $I_f = |E_{th}|^2 / X_{th}$

**FAULT ANALYSIS USING Z-BUS MATRIX – ALGORITHM AND FLOW CHART.****Bus impedance matrix**

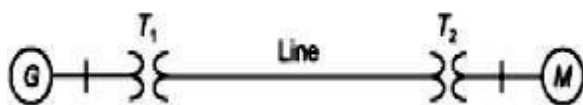
Bus impedance matrix is the inverse of the bus admittance matrix. The matrix consisting of driving point impedance and transfer impedances of the network is called as bus impedance matrix. Bus impedance matrix is symmetrical.

**Methods available for forming bus impedance matrix**

- (i). Form bus admittance matrix and take the inverse to get bus impedance matrix.
- (ii). Using bus building algorithm.
- (iii). Using L-U factorization of Y-bus matrix.

**3.5 SOLVED PROBLEMS****Problem 1**

A synchronous generator and a synchronous motor each rated 20MVA, 12.66KV having 15% reactance are connected through transformers and a line as shown in fig. the transformers are rated 20MVA, 12.66/66KV and 66/12.66KV with leakage reactance of 10% each. The line has a reactance of 8% on base of 20MVA, 66 KV. The motor is drawing 10MW at 0.8 leading power factors and a terminal voltage 11KV when symmetrical three phase fault occurs at the motors terminals. Determine the generator and motor currents. Also determine the fault current.



All reactances are given on a base of 20 MVA and appropriate voltages.

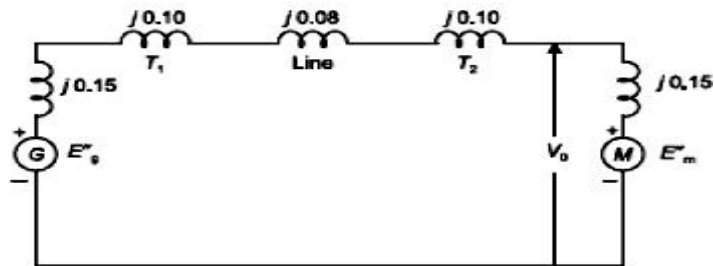
Prefault voltage  $V_0 = \frac{11}{12.66} \angle 0^\circ = 0.8688 \angle 0^\circ \text{ pu.}$

Load = 10 MW, 0.80 power factor (leading) =  $\frac{10}{20} = 0.50 \text{ pu.}$

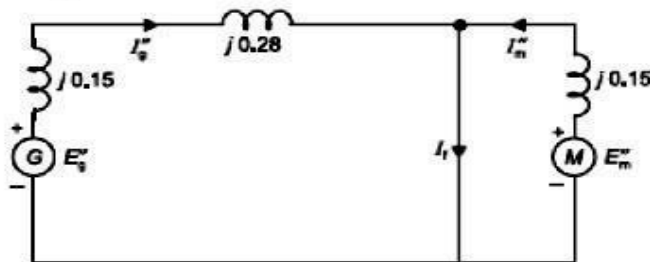
Prefault current  $I_0 = \frac{0.50}{0.8688 \times 0.80} \angle 36.87^\circ$

$\therefore I_0 = 0.7194 \angle 36.87^\circ \text{ pu}$

Reactance diagram

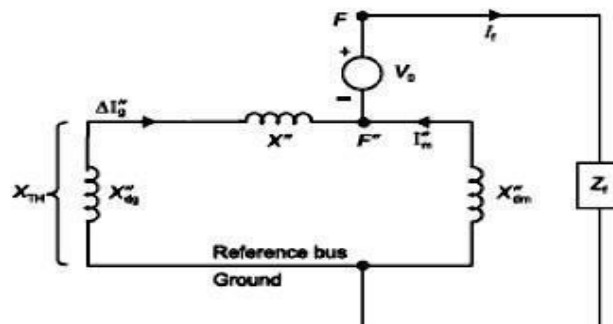


Equivalent circuit during fault condition



$X'' = j(0.1 + 0.08 + 0.01) = j0.28$

$X_{dg} = j0.15, X_{dm} = j0.15$



$$X_{dg}'' + X'' = j(0.15 + 0.28) = j0.43$$

$$\therefore X_{TH} = \frac{(X_{dg}'' + X'')(X_{dg}'')}{(X_{dg}'' + X'' + X_{dm}'')} = \frac{j0.43 \times j0.15}{j(0.43 + 0.15)}$$

$$X_{TH} = j0.1112 \text{ pu}$$

$$\therefore I_f = \frac{V_0}{(Z_f + X_{TH})} = \frac{0.8688 \angle 0^\circ}{j0.1112} \text{ [since } z_f = z_0]$$

$$\therefore I_f = -j7.811 \text{ pu.}$$

Change in generator current

$$\Delta I_g'' = I_f \times \frac{X_{dm}''}{(X_{dg}'' + X'' + X_{dm}'')}$$

$$\therefore \Delta I_g'' = -j7.811 \times \frac{j0.15}{j(0.15 + 0.28 + 0.15)}$$

$$\Delta I_g'' = -j2.02 \text{ pu}$$

Similarly,

$$\Delta I_m'' = -j7.811 \times \frac{j(0.15 + 0.28)}{j0.58}$$

$$\therefore \Delta I_m'' = -j5.79 \text{ pu}$$

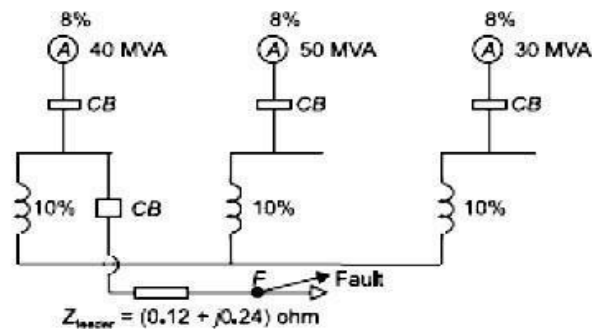
Therefore,

$$I_g'' = \Delta I_g'' + I_0 = -j2.02 + 0.7194 \angle 36.87^\circ$$

$$\therefore I_g'' = (0.575 - j1.589) \text{ pu}$$

$$I_m'' = \Delta I_m'' - I_0 = -j5.79 - 0.7194 \angle 36.87^\circ$$

Three 11.2 KV generators are interconnected as shown in figure by a tie -bar through current limiting reactors. A three phase feeder is supplied from the bus bar of generator A at line voltage 11.2 KV. Impedance of the feeder is  $(0.12+j0.24)$  ohm per phase. Compute the maximum MVA that can be fed into a symmetrical short circuit at the far end of the feeder.



**Solution:** Generator reactance

$$x_{Ag} = 8\% = 0.08 \text{ pu}, x_{Bg} = x_{Cg} = 0.08 \text{ pu}$$

Reactor reactance

$$x_A = x_B = x_C = 10\% = 0.10 \text{ pu}$$

Feeder impedance

$$Z_{feeder} = (0.12 + j0.24) \text{ ohm.}$$

choose a base 50 MVA, 11.2 KV

Base impedance  $Z_B = \frac{(11.2)^2}{50} \text{ ohm} = 2.5088 \text{ ohm}$

$$\therefore Z_{feeder} (\text{pu}) = \frac{Z_{feeder}(\text{ohm})}{Z_B} = \frac{(0.12 + j0.24)}{2.5088}$$

$$\therefore Z_{feeder} (\text{pu}) = (0.0478 + j0.0956) \text{ pu.}$$

$$x_{Ag} = j0.08 \times \frac{50}{40} = j0.10 \text{ pu}$$

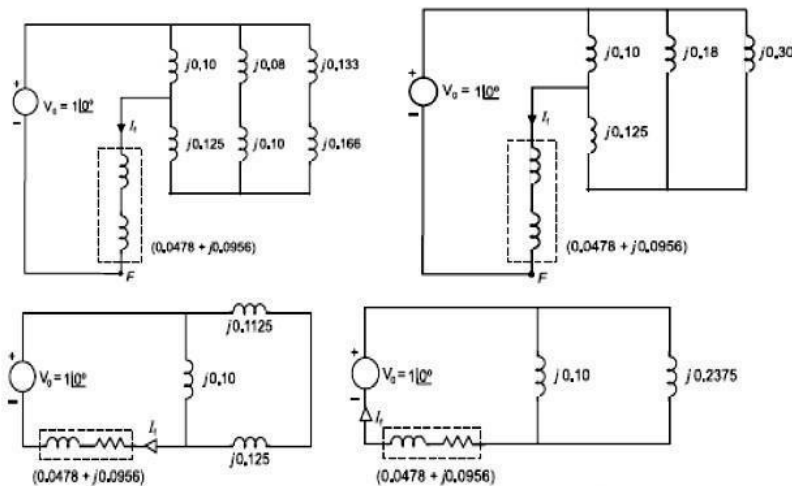
$$x_{Bg} = j0.08 \text{ pu}$$

$$x_{Cg} = j0.08 \times \frac{50}{30} = j0.133 \text{ pu}$$

$$x_A = j0.10 \times \frac{50}{40} = j0.125 \text{ pu}$$

$$x_B = j0.10 \text{ pu}$$

$$x_C = j0.10 \times \frac{50}{30} = j0.166 \text{ pu}$$



Assume a zero pre-fault current (no load pre-fault condition). Circuit model for the fault calculation is given

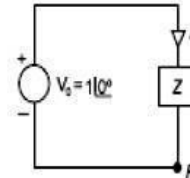
$$Z = 0.0478 + j0.0956 + j \frac{0.10 \times 0.2375}{0.3375}$$

$$\therefore Z = 0.1727 \angle 73.94^\circ \text{ pu.}$$

Short circuit  $MVA = |V_0| |I_f| \times (MVA)_{Base}$

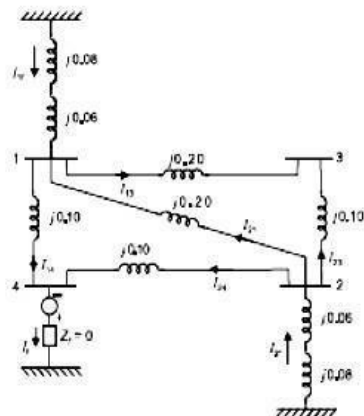
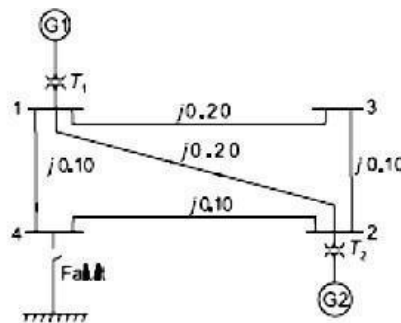
$$= |V_0| \times \frac{|V_0|}{|Z|} \times (MVA)_{Base}$$

$$= \frac{(1)^2}{0.1727} \times 50 = 289.5 \text{ MVA Ans.}$$



A 4 bus sample power system is shown in fig. Perform the short circuit analysis for a three phase solid fault on bus 4. data are given below

- G1: 11.2KV, 100MVA, X=0.08 p.u
  - G1: 11.2KV, 100MVA, X=0.08 p.u
  - T1: 11/110KV, 100MVA, X=0.06 p.u
  - T2: 11/110KV, 100MVA, X=0.06 p.u
- Assume pre-fault voltages 1.0 p.u and pre-fault currents to be zero.



$$I_f = \frac{V_{f0}}{Z} = \frac{1 \angle 0^\circ}{j0.12} = -j8.33 \text{ pu}$$

$$I_{f1} = I_{f2} = -j8.33 \times \frac{j0.1775}{j(0.1775 + 0.1775)}$$

$$= -j4.165 \text{ pu.}$$

Now  $\frac{E_{g1}^0 - V_{f1}}{j0.14} = I_{f1} = -j4.165$

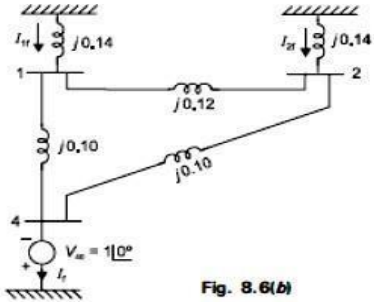
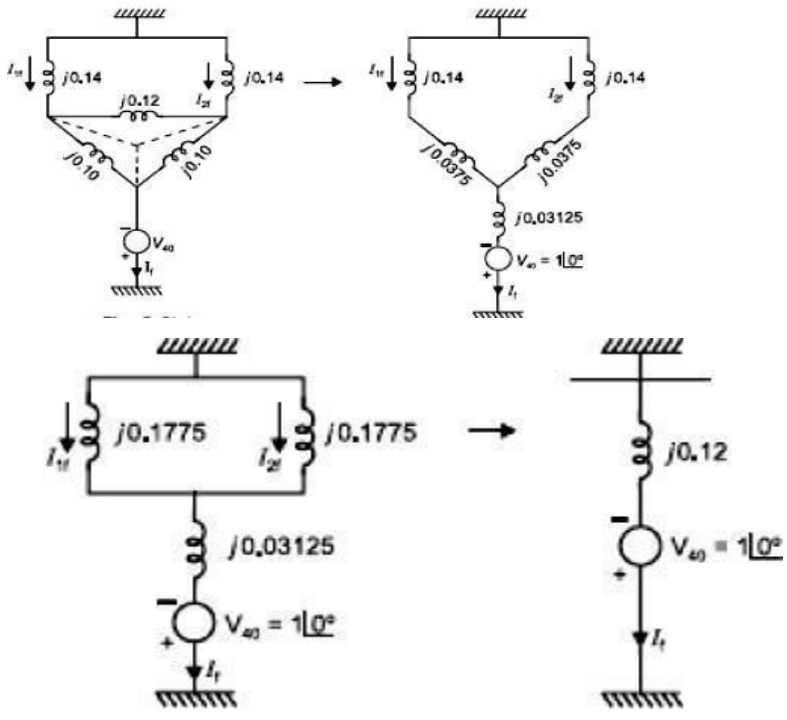


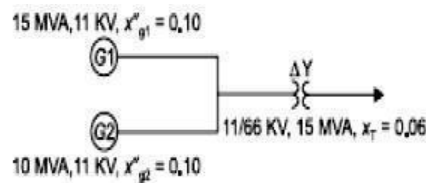
Fig. 8.6(b)



$$\begin{aligned} \therefore 1 - V_{1f} &= j0.14 \times (-j4.165) \\ \therefore V_{1f} &= 0.4169 \text{ pu.} \\ \text{Similarly} \\ 1 - V_{2f} &= j0.14 \times (-j4.165) \\ \therefore V_{2f} &= 0.4169 \text{ pu.} \\ V_{4f} &= 0.0 \\ I_{24} &= \frac{V_{2f} - V_{4f}}{j0.10} = \frac{0.4169}{j0.10} = -j4.169 \\ I_{21} &= \frac{V_{2f} - V_{1f}}{j0.20} = \frac{0.4169 - 0.4169}{j0.20} = 0.0 \\ I_{2f} &= I_{24} + I_{21} + I_{23} = -j4.169 + 0.0 + I_{23} \\ \therefore -j4.165 &= -j4.169 + I_{23} \\ \therefore I_{23} &= j0.004 \text{ pu.} \\ \text{Now} \\ \frac{V_{2f} - V_{3f}}{j0.10} &= I_{23} = j0.004 \\ \therefore V_{3f} &= V_{2f} - j0.004 \times j0.10 = 0.4169 + 0.0004 \\ \therefore V_{3f} &= 0.4173 \text{ pu.} \\ I_{13} &= \frac{V_{1f} - V_{3f}}{Z_{12}} = \frac{(0.4169 - 0.4173)}{j0.20} \\ \therefore I_{13} &= -j0.002 \text{ pu} \\ \text{SC MVA at bus 4} \end{aligned}$$

$$\begin{aligned} &= |I_f| \times (\text{MVA})_{\text{Base}} \\ &= 8.33 \times 100 \text{ MVA} \\ &= 833 \text{ MVA} \end{aligned}$$

Two generators G1 and G2 are rated 15MVA, 11KV and 10MVA, 11KV respectively. The generators are connected to a transformer as shown in fig. Calculate the sub transient current in each generator when a three phase fault occurs on the high voltage side of the transformer.



**Solution:** Choose a base 15 MVA

$$\begin{aligned} x''_{g1} &= j0.10 \text{ pu} \\ x''_{g2} &= j0.10 \times \frac{15}{10} = j0.15 \text{ pu} \end{aligned}$$



$x_T = j0.06 \text{ pu}$

$$I_f = \frac{V_o}{j0.12} = \frac{1}{j0.12} = -j8.33 \text{ pu}$$

$$I'_{g1} = \frac{j0.15}{j(0.1+0.15)} \times (-j8.33) = -j5.0 \text{ pu}$$

$$I'_{g2} = \frac{j0.10}{j(0.1+0.15)} \times (-j8.33) = -j3.33 \text{ pu}$$

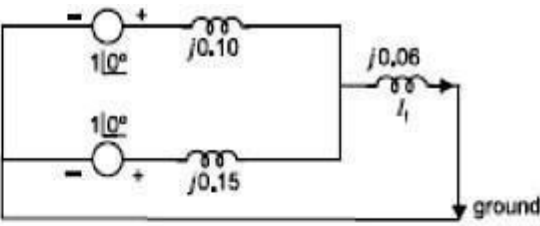
Base current

$$I_B = \frac{15 \times 1000}{\sqrt{3} \times 11} = 787.3 \text{ Amp.}$$

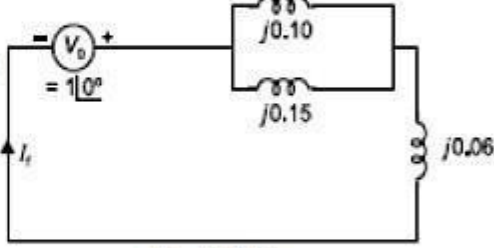
$\therefore I'_{g1} = -j5 \times 787.3 = -j3.936 \text{ KA.}$

$I'_{g2} = -j3.33 \times 787.3 = -j2.621 \text{ KA.}$

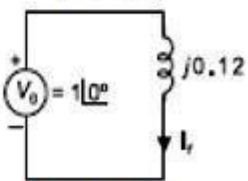
$I_f = -j8.33 \times 787.3 = -j6.557 \text{ KA.}$



**Fig. 8.7(a)**

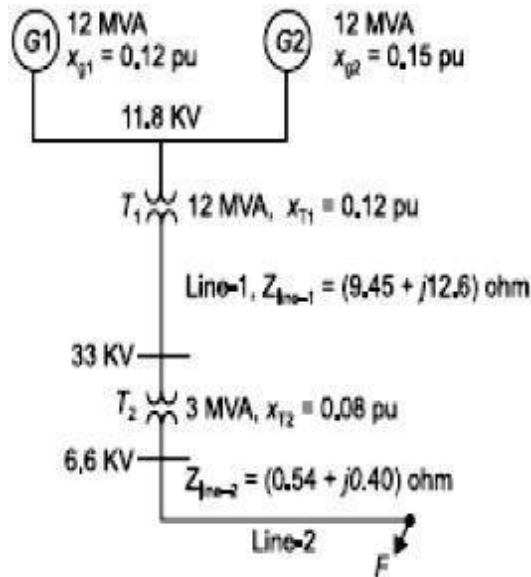


**Fig. 8.7(b)**



**Fig. 8.7(c)**

A radial power system network is shown in fig. a three phase balanced fault occurs at F. Determine the fault current and the line voltage at 11.8 KV bus under fault condition.



**Solution:**

Let Base MVA = 12

Base Voltage = 11.8 KV.

$$x_{g1} = j0.12 \text{ pu}, \quad x_{g2} = j0.15 \text{ pu}$$

$$x_{T1} = j0.12 \text{ pu},$$

$$x_{T2} = j0.08 \times \frac{12}{3} = j0.32 \text{ pu}$$

Base voltage for line-1 is 33 KV.

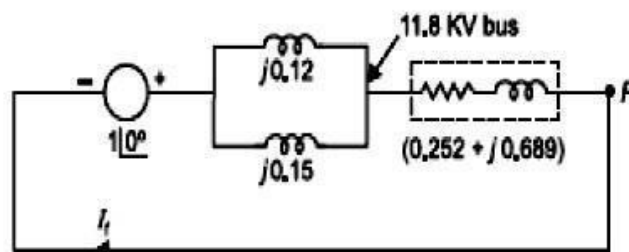
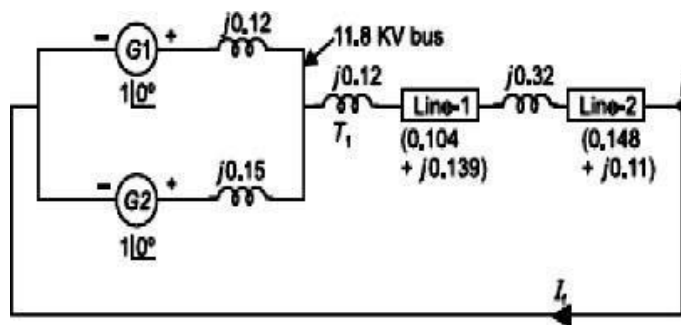
Base voltage for line-2 is 6.6 KV.

$$Z_{B, \text{line-1}} = \frac{(33)^2}{12} = 90.75 \text{ ohm.}$$

$$Z_{B, \text{line-2}} = \frac{(6.6)^2}{12} = 3.63 \text{ ohm.}$$

$$\therefore Z_{\text{line-1}} = \frac{(9.45 + j12.6)}{90.75} = (0.104 + j0.139) \text{ pu}$$

$$Z_{\text{line-2}} = \frac{(0.54 + j0.40)}{3.63} = (0.148 + j0.11) \text{ pu}$$



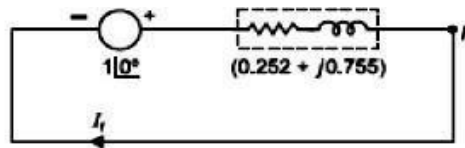


Fig. 8.12(c)

Base current  $I_B = \frac{12 \times 1000}{\sqrt{3} \times 6.6} = 1049.7 \text{ Amp.}$

Now  $I_f = \frac{1 \angle 0^\circ}{(0.252 + j0.755)} = 1.256 \angle -71.5^\circ \text{ pu}$

$\therefore I_f = 1.256 \angle -71.5^\circ \times 1049.7$

$\therefore I_f = 1318.4 \angle -71.5^\circ \text{ Amp.}$

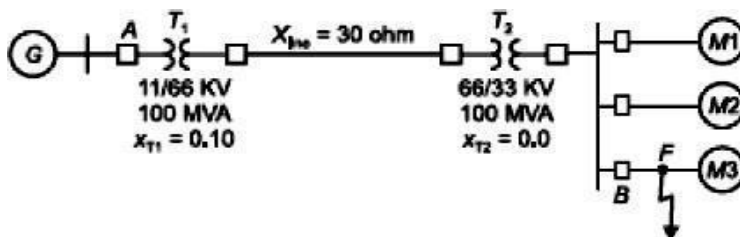
Total impedance between F and 11.8 KV bus  
 $= (0.252 + j0.689) \text{ pu}$

Voltage at 11.8 KV bus  
 $= 1.256 \angle -71.5^\circ \times (0.252 + j0.689)$   
 $= 0.921 \angle -16^\circ \text{ pu}$   
 $= 0.921 \angle -16^\circ \times 118 \text{ KV}$   
 $= 108.6 \angle -16^\circ \text{ KV. Ans.}$

**Problem : 2**

A 100MVA, 11KV generator with  $X''=0.20 \text{ p.u}$  is connected through a transformer and line to a bus bar that supplies three identical motor as shown in fig. and each motor has  $X''=0.20 \text{ p.u}$  and  $X'=0.25 \text{ p.u}$  on a base of 20MVA, 33KV. the bus voltage at the motors is 33KV when a three phase balanced fault occurs at the point F. Calculate

- (a) subtransient current in the fault
- (b) subtransient current in the circuit breaker B
- (c) Momentary current in the circuit breaker B
- (d) The current to be interrupted by CB B in (i) 2 cycles (ii) 3 cycles (iii) 5 cycles (iv) 8 cycles



**Solution:**

Let Base MVA = 100

Base Voltage = 11 KV.

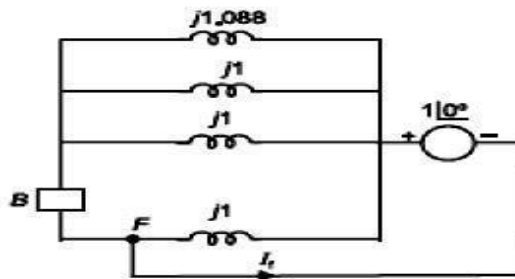
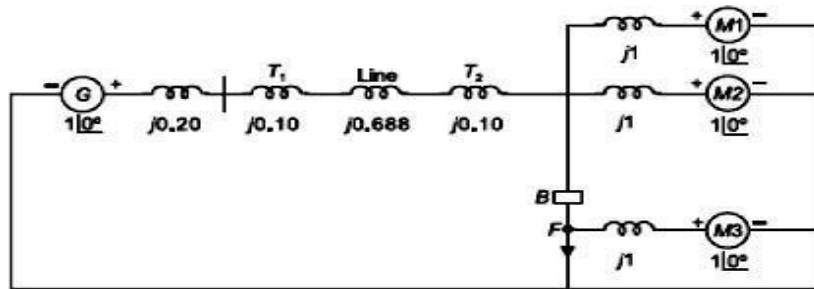
$$x_g^r = j0.20 \text{ pu.}$$

$$x_m^r = x_{m1}^r = x_{m2}^r = x_{m3}^r = j0.2 \times \frac{100}{20} = j1.0 \text{ pu.}$$

$$x_m' = x_{m1}' = x_{m2}' = x_{m3}' = j0.25 \times \frac{100}{20} = j1.25 \text{ pu.}$$

$$x_{T1} = x_{T2} = j0.10 \text{ pu}$$

$$x_{\text{line}} = 30 \times \frac{100}{(66)^2} = j0.688 \text{ pu.}$$



$$\therefore x_{eq} = \frac{j}{3919} = j0.255$$

$$\therefore I_f = \frac{1 \angle 0^\circ}{j0.255} = -j3.919 \text{ pu.}$$

Base current for 33 KV circuit

$$I_B = \frac{100 \times 1000}{\sqrt{3} \times 33} = 1.75 \text{ KA.}$$

$$\therefore |I_f| = 3.919 \times 1.75 = 6.85 \text{ KA.}$$

(b) Current through circuit breaker B is,

$$I_B = \frac{2}{j1} + \frac{1}{j1.088} = -j2.919 \text{ pu}$$

$$\therefore |I_{fB}| = 2.919 \times 1.75 = 5.108 \text{ KA.}$$

(c) Momentary current can be calculated by multiplying the symmetrical momentary current by a factor of 1.6 to account for the presence of DC off-set current.

$$\therefore \text{Momentary current through breaker B} \\ = 1.6 \times 5.108 \text{ KA} = 8.17 \text{ KA.}$$

(d) For computing the current to be interrupted by the breaker, motor  $x_m^r$  ( $x_m^r = j10$ ) is now replaced by  $x_m'$  ( $x_m' = j1.25 \text{ pu}$ ). The equivalent circuit is shown in Fig. 8.13(c).

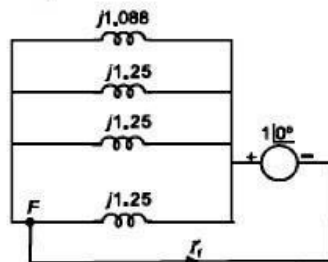


Fig. 8.13(c)

$$x_{eq} = j0.3012$$

Current to be interrupted by the breaker

$$I_f' = \frac{1}{j0.3012} = -j3.32 \text{ pu}$$

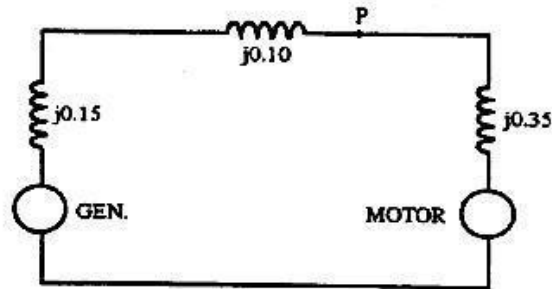
Allowance is made for the DC off-set value by multiplying with a factor of (i) 1.4 for 2 cycles (ii) 1.2 for 3 cycles (iii) 1.1 for 5 cycles (iv) 1.0 for 8 cycles.

Therefore, current to be interrupted as:

- (i)  $1.4 \times 3.32 \times 1.75 = 8.134 \text{ KA}$
- (ii)  $1.2 \times 3.32 \times 1.75 = 6.972 \text{ KA}$
- (iii)  $1.1 \times 3.32 \times 1.75 = 6.391 \text{ KA}$
- (iv)  $1.0 \times 3.32 \times 1.75 = 5.81 \text{ KA.}$

A generator is connected through a transformer to a synchronous motor. Reduced to the same base, the per-unit subtransient reactances of the generator and motor are 0.15 and 0.35, respectively, and the leakage reactance of the transformer is 0.10 per unit. A three-phase fault occurs at the terminals of the motor when the terminal voltage of the generator is 0.9 per unit and the output current of the generator is 1.0 per unit at 0.8 power factor leading. Find the subtransient current in per unit in the fault, in the generator and in the motor. Use the terminal voltage of the generator as the reference phasor and obtain the solution (a) by computing the voltages behind subtransient reactance in the generator and motor and (b) by using Thévenin's theorem.

Solution:



P: fault point

(a)

(a)

$$\begin{aligned} E_g'' &= 0.9 + (0.8 + j0.6)(j0.15) = 0.81 + j0.12 \text{ per unit} \\ E_m'' &= 0.9 - (0.8 + j0.6)(j0.45) = 1.17 - j0.36 \text{ per unit} \\ I_g'' &= \frac{0.81 + j0.12}{j0.25} = 0.48 - j3.24 \text{ per unit} \end{aligned}$$

$$\begin{aligned} I_m'' &= \frac{1.17 - j0.36}{j0.35} = -1.03 - j3.34 \text{ per unit} \\ I_f'' &= I_g'' + I_m'' = -0.55 - j6.58 \text{ per unit} \end{aligned}$$

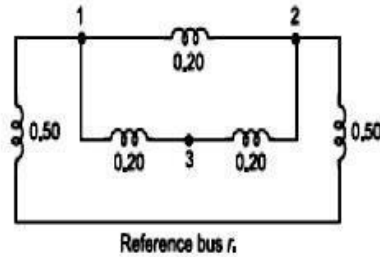
(b)

$$\begin{aligned} V_f &= 0.9 - (0.8 + j0.6)(j0.1) = 0.96 - j0.08 \text{ per unit} \\ Z_{th} &= \frac{j0.25 \times j0.35}{j0.60} = j0.146 \text{ per unit} \\ I_f'' &= \frac{0.96 - j0.08}{j0.146} = -0.55 - j6.58 \text{ per unit} \end{aligned}$$

By replacing  $I_f''$  by a current source and then applying the principle of superposition,

$$\begin{aligned} I_g'' &= 0.8 + j0.6 + \frac{j0.35}{j0.60} (-0.55 - j6.58) = 0.48 - j3.24 \text{ per unit} \\ I_m'' &= -0.8 - j0.6 + \frac{j0.25}{j0.60} (-0.55 - j6.58) = -1.03 - j3.34 \text{ per unit} \end{aligned}$$

Obtain impedance matrix  $Z_{BUS}$  for shown in figure.



**Solution:**

**Step-1:** Add branch  $Z_{1r} = 0.50$  (from new bus 1 to reference bus  $r$ )

$$\therefore Z_{\text{BUS}} = [0.50] \quad \dots (i)$$

**Step-2:** Type-2 modification. That is add branch  $Z_{21} = 0.20$  (from new bus 2 to old bus 1)

$$\therefore Z_{\text{BUS}} = \frac{1}{2} \begin{bmatrix} 0.50 & 0.50 \\ 0.50 & 0.70 \end{bmatrix} \quad \dots (ii)$$

**Step-3:** Add branch  $Z_{13} = 0.20$  from new bus 3 to old bus 1. This is type-2 modification.

$$\therefore Z_{\text{BUS}} = \begin{bmatrix} 0.50 & 0.50 & 0.50 \\ 0.50 & 0.70 & 0.50 \\ 0.50 & 0.50 & 0.70 \end{bmatrix}$$

**Step-4:** Add branch  $Z_{2r}$  from old bus 2 to reference bus  $r$ . This is type-3 modification.

$$\therefore Z_{\text{BUS}} = \begin{bmatrix} 0.50 & 0.50 & 0.50 \\ 0.50 & 0.70 & 0.50 \\ 0.50 & 0.50 & 0.70 \end{bmatrix} - \frac{1}{(0.7 + 0.50)} \begin{bmatrix} 0.50 \\ 0.70 \\ 0.50 \end{bmatrix} [0.5 \quad 0.7 \quad 0.5]$$

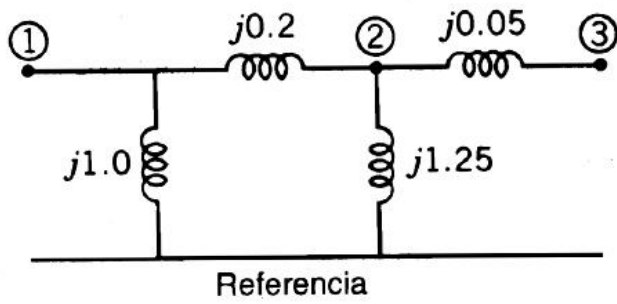
$$\therefore Z_{\text{BUS}} = \begin{bmatrix} 0.2916 & 0.2084 & 0.2916 \\ 0.2084 & 0.2916 & 0.2084 \\ 0.2916 & 0.2084 & 0.4916 \end{bmatrix}$$

**Step-5:** Add branch  $Z_{23} = 0.20$  from old bus 2 to old bus 3. This is type-4 modification.

$$\therefore Z_{\text{BUS}} = \begin{bmatrix} 0.2916 & 0.2084 & 0.2916 \\ 0.2084 & 0.2916 & 0.2084 \\ 0.2916 & 0.2084 & 0.4916 \end{bmatrix} - \frac{1}{(0.20 + 0.2916 + 0.4916 - 2 \times 0.2084)} \begin{bmatrix} -0.0832 \\ 0.0832 \\ -0.2832 \end{bmatrix} [-0.0832 \quad 0.0832 \quad -0.2832]$$

$$\therefore Z_{\text{BUS}} = \begin{bmatrix} 0.2793 & 0.2206 & 0.2500 \\ 0.2206 & 0.2793 & 0.2500 \\ 0.2500 & 0.2500 & 0.3500 \end{bmatrix}$$

Obtain impedance matrix  $Z_{\text{BUS}}$  for shown in figure



Solution:

$$0-1 \quad j \begin{bmatrix} 1.0 \\ 1.0 \end{bmatrix} \quad 0-2 \quad j \begin{bmatrix} 1.0 & 0 \\ 0 & 1.25 \end{bmatrix}$$

$$1-3 \quad j \begin{bmatrix} 1 & 0 & 0 \\ 0 & 1.25 & 1.25 \\ 0 & 1.25 & 1.3 \end{bmatrix}$$

$$1-2 \quad j \left[ \begin{array}{ccc|c} 1 & 0 & 0 & 1 \\ 0 & 1.25 & 1.25 & -1.25 \\ 0 & 1.25 & 1.3 & -1.25 \\ \hline 1 & -1.25 & -1.25 & 2.45 \end{array} \right]$$

After kron reduction,  $Z_{BUS}$  is given by:

$$j \begin{bmatrix} 0.5918 & 0.5102 & 0.5102 \\ 0.5102 & 0.6122 & 0.6122 \\ 0.5102 & 0.6122 & 0.6622 \end{bmatrix}$$



## UNIT- IV

## SYMMETRICAL COMPONENTS AND UNBALANCED FAULT ANALYSIS

## INTRODUCTION TO SYMMETRICAL COMPONENTS

**Symmetrical components of a 3 phase system**

In a 3 phase system, the unbalanced vectors (either currents or voltage) can be resolved into three balanced system of vectors.

They are Positive sequence components

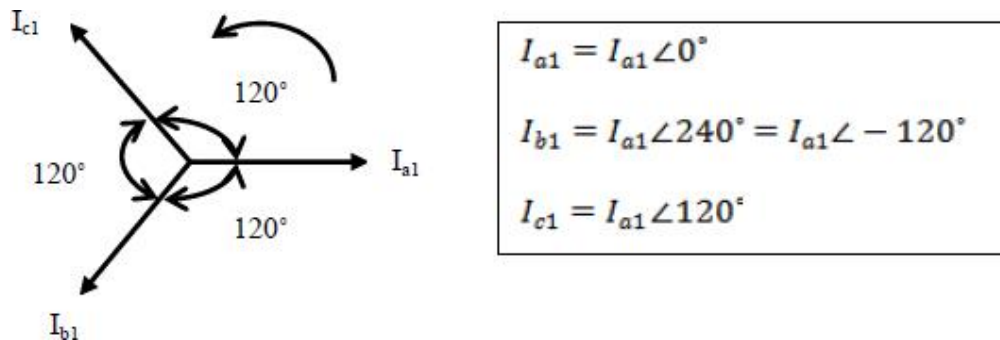
Negative sequence components

Zero sequence components

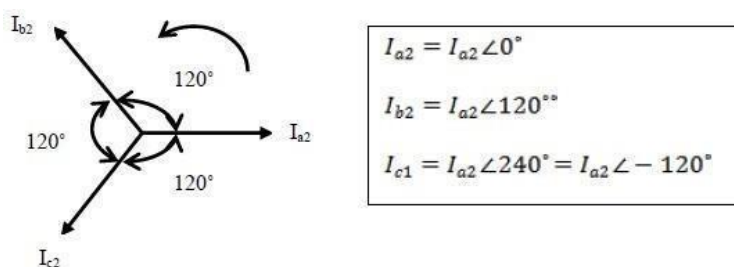
Unsymmetrical fault analysis can be done by using symmetrical components.

**Positive sequence components**

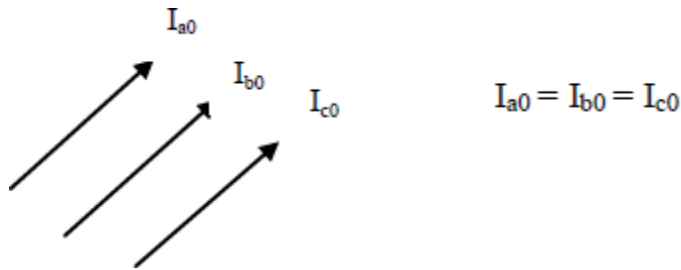
It consists of three components of equal magnitude, displaced each other by  $120^\circ$  in phase and having the phase sequence abc .

**Negative sequence components**

It consists of three components of equal magnitude, displaced each other by  $120^\circ$  in phase and having the phase sequence acb .

**Zero sequence components**

It consists of three phasors equal in magnitude and with zero phase displacement from each other.

**Sequence operator**

In unbalanced problem, to find the relationship between phase voltages and phase currents, we use sequence operator 'a'.

$$a = 1 \angle 120^\circ = -0.5 + j0.866$$

$$a^2 = 1 \angle 240^\circ = -0.5 - j0.866$$

$$1 + a + a^2 = 0$$

**Unbalanced currents from symmetrical currents**

Let,  $I_a, I_b, I_c$  be the unbalanced phase currents

Let,  $I_{a0}, I_{a1}, I_{a2}$  be the symmetrical components of phase a

$$\begin{bmatrix} I_a \\ I_b \\ I_c \end{bmatrix} = \begin{bmatrix} 1 & 1 & 1 \\ 1 & a^2 & a \\ 1 & a & a^2 \end{bmatrix} \begin{bmatrix} I_{a0} \\ I_{a1} \\ I_{a2} \end{bmatrix}$$

**Determination of symmetrical currents from unbalanced currents.**

Let,  $I_a, I_b, I_c$  be the unbalanced phase currents

Let,  $I_{a0}, I_{a1}, I_{a2}$  be the symmetrical components of phase a

$$\begin{bmatrix} I_{a0} \\ I_{a1} \\ I_{a2} \end{bmatrix} = \frac{1}{3} \begin{bmatrix} 1 & 1 & 1 \\ 1 & a & a^2 \\ 1 & a^2 & a \end{bmatrix} \begin{bmatrix} I_a \\ I_b \\ I_c \end{bmatrix}$$

**SEQUENCE IMPEDANCES SEQUENCE NETWORKS**

The sequence impedances are the impedances offered by the power system components or elements to +ve, -ve and zero sequence current.

The single phase equivalent circuit of power system consisting of impedances to current of any one sequence only is called sequence network.

The phase voltage across a certain load are given as

$$V_a = (176 - j132) \text{ Volts}$$

$$V_b = (-128 - j96) \text{ Volts}$$

$$V_c = (-160 + j100) \text{ Volts}$$

Compute positive, negative and zero sequence component of voltage

**Solution:**

$$V_{a1} = \frac{1}{3}(V_a + \beta V_b + \beta^2 V_c)$$

$$V_{a2} = \frac{1}{3}(V_a + \beta^2 V_b + \beta V_c)$$

$$V_{a0} = \frac{1}{3}(V_a + V_b + V_c)$$

$$V_{a1} = \frac{1}{3}\{176 - j132 + 1\angle 120^\circ \times (-128 - j96) + 1\angle 240^\circ (-160 + j100)\}$$

$$V_{a1} = (163.24 - j35.10) \text{ Volts}$$

$$V_{a2} = \frac{1}{3}\{176 - j132 + 1\angle 240^\circ (-128 - j96) + 1\angle 120^\circ (-160 + j100)\}$$

$$V_{a2} = (50.1 - j53.9) \text{ Volts}$$

$$V_{a0} = \frac{1}{3}(176 - j132 - 128 - j96 - 160 + j100) \text{ Volts}$$

A balanced delta connected load is connected to a three phase system and supplied to it is a current of 15 amps. If the fuse is one of the lines melts, compute the symmetrical components of line currents.

**Solution:**

$$I_a = -I_c, I_b = 0$$

$$I_a = 15\angle 0^\circ; I_c = 15\angle 180^\circ = -15$$

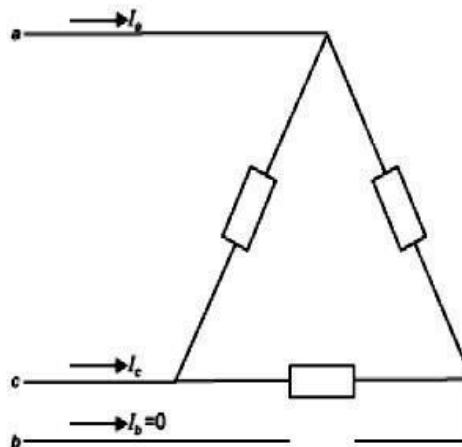
$$\therefore I_{a1} = \frac{1}{3}(I_a + \beta I_c + \beta^2 I_b)$$

$$= (7.5 + j4.33) \text{ Amp.}$$

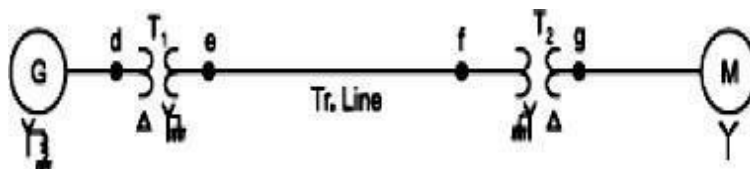
$$I_{a2} = \frac{1}{3}(I_a + \beta^2 I_c + \beta I_b)$$

$$= (7.5 + j4.33) \text{ Amp.}$$

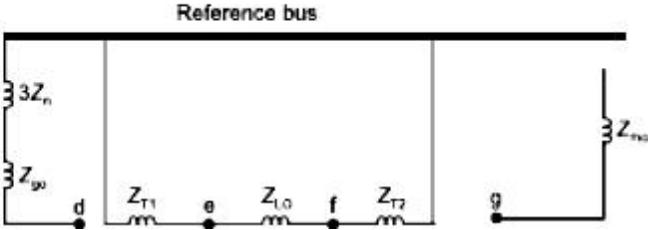
$$I_{a0} = \frac{1}{3}(I_a + I_b + I_c) = 0.0$$



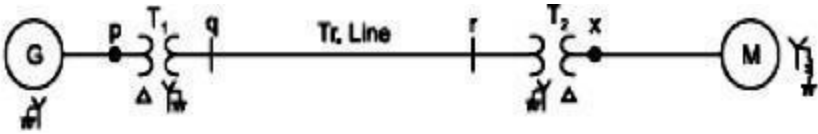
Draw zero sequence network of the power system as shown in fig.



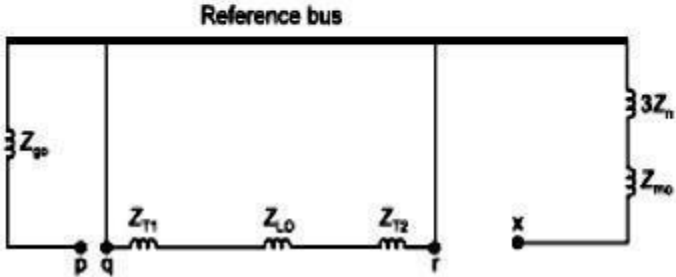
**Solution:**



Draw zero sequence network of the power system as shown in fig.

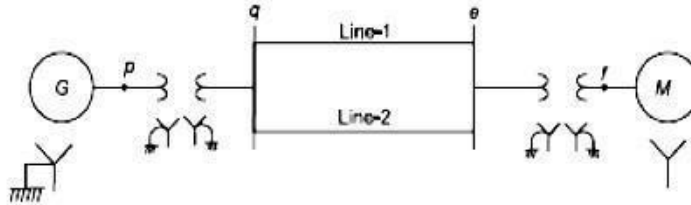


**Solution:**

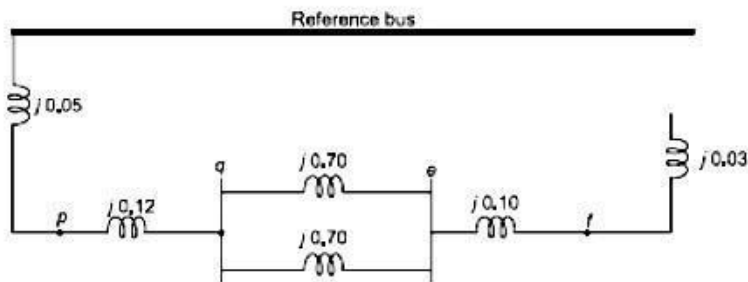


Draw zero sequence network of the power system as shown in fig. Data are given below.

G:  $x_{g0} = 0.05 \text{ pu}$   
M:  $x_{m0} = 0.03 \text{ pu}$   
 $T_1$ :  $x_{T1} = 0.12 \text{ pu}$   
 $T_2$ :  $x_{T2} = 0.10 \text{ pu}$   
Line-1:  $x_{L10} = 0.70 \text{ pu}$   
Line-2:  $x_{L20} = 0.70 \text{ pu}$

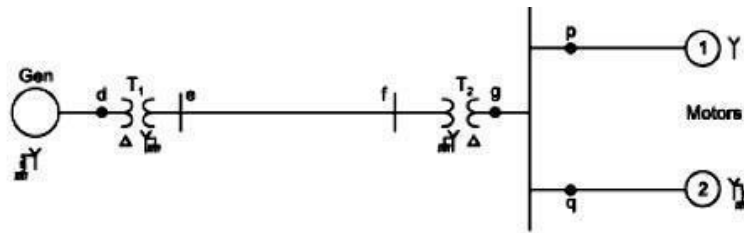


**Solution:**



### REPRESENTATION OF SINGLE LINE TO GROUND, LINE TO LINE AND DOUBLE LINE TO GROUND FAULT CONDITIONS.

A 50MVA, 11KV, synchronous generator has a sub transient reactance of 20%. The generator supplies two motors over a transmission line with transformers at both ends as shown in fig. The motors have rated inputs of 30 and 15 MVA, both 10KV, with 25% sub transient reactance. The three phase transformers are both rated 60MVA, 10.8/121KV, with leakage reactance of 10% each. Assume zero sequence reactance for the generator and motors of 6% each. Current limiting reactors of 2.5 ohms each are connected in the neutral of the generator and motor number 2. The zero sequence reactance of the transmission line is 300 ohms. The series reactance of the line is 100 ohms. Draw the positive, negative and zero sequence networks.



Assume that the negative sequence reactance of each machine is equal to its subtransient reactance.

**Solution:**

Assume base power = 50 MVA

base voltage = 11 KV

Base voltage of transmission line

$$= 11 \times \frac{121}{10.8} = 123.2 \text{ KV}$$

$$\text{Motor base voltage} = 123.2 \times \frac{10.8}{121} = 11 \text{ KV}$$

Transformer reactance,

$$x_{T1} = x_{T2} = 0.10 \times \frac{50}{60} \times \left(\frac{10.8}{11}\right)^2 = 0.0805 \text{ pu}$$

Line reactance (positive & negative sequence)

$$= \frac{100 \times 50}{(123.2)^2} \text{ pu} = 0.33 \text{ pu}$$

Line reactance (zero sequence)

$$= \frac{300 \times 50}{(123.2)^2} = 0.99 \text{ pu}$$

Reactance of motor 1 (positive and negative sequence)

$$= 0.25 \times \frac{50}{30} \times \left(\frac{10}{11}\right)^2 = 0.345 \text{ pu}$$

Zero-sequence reactance of motor 1

$$= 0.06 \times \frac{50}{30} \times \left(\frac{10}{11}\right)^2$$

$$= 0.082 \text{ pu}$$

Reactance of motor 2 (positive and negative sequence)

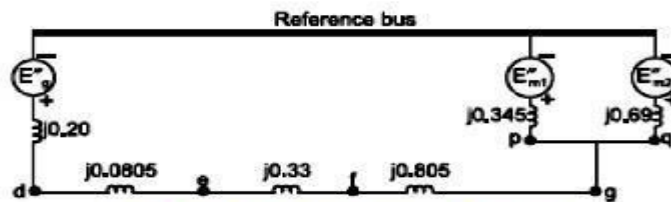
$$= 0.25 \times \frac{50}{15} \times \left(\frac{10}{11}\right)^2 = 0.69 \text{ pu}$$

**Zero-sequence reactance of motor 2**

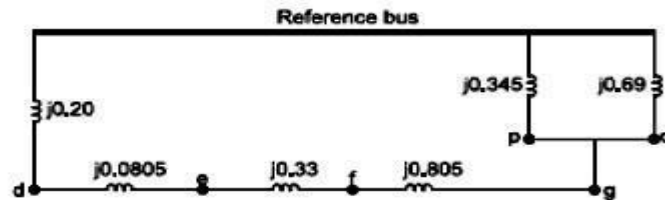
$$= 0.06 \times \frac{50}{15} \times \left(\frac{10}{11}\right)^2 = 0.164 \text{ pu}$$

**Reactance of reactors =  $2.5 \times \frac{50}{(11)^2} = 1.033 \text{ pu}$**

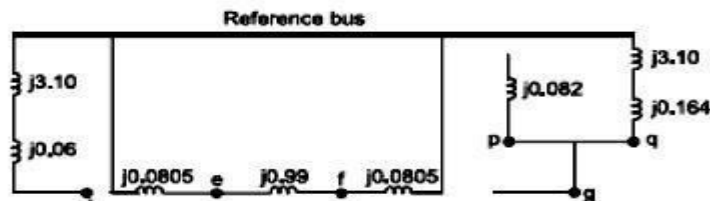
Positive, negative and zero-sequence diagram are given below:



**Fig. 9.10(a): Positive sequence network.**



**Fig. 9.10(b): Negative sequence network.**



**Fig. 9.10(c): Zero-sequence network.**

**UNBALANCED FAULT ANALYSIS PROBLEM FORMULATION**

A 30 MVA, 13.2KV synchronous generator has a solidly grounded neutral. Its positive, negative and zero sequence impedances are 0.30, 0.40 and 0.05 p.u respectively. Determine the following:

- What value of reactance must be placed in the generator neutral so that the fault current for a line to ground fault of zero fault impedance shall not exceed the rated line current?
- What value of resistance in the neutral will serve the same purpose?
- What value of reactance must be placed in the neutral of the generator to restrict the fault current to ground to rated line current for a double line to ground fault?
- What will be the magnitudes of the line currents when the ground current is restricted as above?
- As the reactance in the neutral is indefinitely increased, what are the limiting values of the line currents?

**Solution:** Rated current of generator is,

$$I_{g, \text{ rated}} = \frac{30,000}{\sqrt{3} \times 13.2} = 1312.16 \text{ Amp.}$$

Taking the rated voltage and MVA as base

$$1 \text{ pu amp} = 1312.16 \text{ Amp.}$$

$$\text{Base impedance} = \frac{(13.2)^2}{30} = 5.888 \Omega$$

$$Z_1 = j0.30 \text{ pu}, Z_2 = j0.40 \text{ pu}, Z_0 = j0.05 \text{ pu}$$

(a) Single-line-to-ground fault

$$I_f = \frac{3E_a}{Z_1 + Z_2 + (Z_0 + 3Z_n)}$$

$$E_a = 1.0 \text{ pu}, I_f = 1.0 \text{ pu},$$

$$Z_0 = j0.05 \text{ pu}, Z_n = X_n = \text{neutral grounding reactance in pu}$$

$$\therefore I_f = \frac{3 \times 1.0}{|j(0.3 + 0.4 + 0.05 + 3X_n)|} = 1.0$$

$$\therefore X_n = 0.75 \text{ pu} = 0.75 \times 5.888 \Omega = 4.416 \Omega$$

(b) If the reactance is replaced by a resistance  $R_n$ , for the same fault current, we can write,

$$|Z_1 + Z_2 + Z_0 + 3R_n| = |j(X_1 + X_2 + X_0) + 3R_n| = 3.0$$

$$\therefore \sqrt{(0.3 + 0.4 + 0.05)^2 + (3R_n)^2} = 3.0$$

$$\therefore R_n = 0.968 \text{ pu} = 0.968 \times 5.888 \Omega = 5.7 \Omega$$

(c) Double line-to-ground fault:

$$I_f = 3 I_{a0} = \frac{-3E_a}{Z_0 + 3Z_f} + \frac{Z_1}{Z_0 + 3Z_f} \cdot \frac{3E_a}{\left(Z_1 + \frac{Z_2(Z_0 + 3Z_f)}{(Z_2 + Z_0 + 3Z_f)}\right)}$$

$$\therefore I_f = \frac{E_a}{Z_0 + 3Z_f} \left( -1 + \frac{Z_1(Z_2 + Z_0 + 3Z_f)}{Z_1(Z_2 + Z_0 + 3Z_f) + Z_2(Z_0 + 3Z_f)} \right)$$

$$\therefore I_f = \frac{-3Z_2 E_a}{Z_1(Z_2 + Z_0 + 3Z_f) + Z_2(Z_0 + 3Z_f)}$$

$$\therefore I_f = \frac{-3Z_2 E_a}{Z_1 Z_2 + (Z_0 + 3Z_f)(Z_1 + Z_2)}$$



$$\therefore \left| \frac{3 \times 1.0 \times j0.4}{j0.3 \times j0.4 + j(0.3 + 0.4)(j0.05 + j3X_n)} \right| = 1.0$$

$$\therefore 0.12 + 0.7(0.05 + 3X_n) = 1.2$$

$$\therefore X_n = 0.5 \text{ pu} = 0.5 \times 5.888 \Omega = 2.944 \Omega$$

(d) Assuming that the phases *b* and *c* are subjected to double line-to-ground fault.

$$\therefore I_b = \beta^2 I_{a1} + \beta I_{a2} + I_{a0}$$

$$\therefore I_b = \frac{[\beta^2(Z_2 + Z_0 + 3Z_f) - \beta(Z_0 + 3Z_f) - Z_2] E_a}{Z_1 Z_2 + (Z_0 + 3Z_f)(Z_1 + Z_2)}$$

$$Z_f = jX_f = j0.5 \text{ pu}, Z_1 = j0.3 \text{ pu}, Z_2 = j0.4 \text{ pu}$$

$$E_a = 1.0 \text{ pu}, Z_0 = j0.05 \text{ pu}$$

$$\therefore I_b = \frac{[\beta^2(j0.4 + j0.05 + \beta \times 0.5) - \beta j(0.05 + 3 \times 0.5) - j0.40] \times 1.0}{j0.3 \times j0.4 + j0.7 \times j(0.05 + 3 \times 0.5)}$$

$$\therefore I_b = \frac{j1.95\beta^2 - j1.55\beta - j0.40}{0.12j^2 + 1.085j^2}$$

$$\therefore I_b = -1.618(j\beta^2) + 1.286(j\beta) + j0.332$$

$$\therefore I_b = (-j1.618)(-0.5 - j0.866) + (j1.286)(-0.5 + j0.866) + j0.332$$

$$\therefore I_b = -1.618(-j0.5 + 0.866) + 1.286(-j0.5 - 0.866) + j0.332$$

$$\therefore I_b = j0.809 - 1.401 - j0.643 - 1.113 + j0.332$$

$$\therefore I_b = (-2.51 + j0.5) \text{ pu} = 2.57 \text{ pu} = 2.57 \times 1312.16 \text{ Amp} = 3.372 \text{ KA}$$

Similarly,  $I_c = \beta I_{a1} + \beta^2 I_{a2} + I_{a0}$

$$\therefore I_c = \frac{[\beta(Z_2 + Z_0 + 3Z_f) - \beta^2(Z_0 + 3Z_f) - Z_2] E_a}{Z_1 Z_2 + (Z_0 + 3Z_f)(Z_1 + Z_2)}$$

$$\therefore I_c = (2.51 + j0.5) \text{ pu} = 2.57 \text{ pu} = 3.372 \text{ KA}$$

(e) As the value of the neutral grounding reactance is indefinitely increased, the values of line-to-line SC currents  $I_b$  and  $I_c$  can be given as

$$|I_b| = |I_c| = \sqrt{3} \left| \frac{E_a}{Z_1 + Z_2} \right| = \sqrt{3} \frac{1.0}{0.70} = 2.474 \text{ pu}$$

$$\therefore |I_b| = |I_c| = 2.474 \times 1312.16 = 3.246 \text{ KA}$$

There is not much difference in fault current obtained in (d) and (e). Therefore, if the neutral grounding impedance is increased to an extremely large value, not much can be done to reduce the severity.

Two alternators are operating in parallel and supplying a synchronous motor which is receiving 60MW power at 0.8 power factor lagging at 6.0 KV. Single line diagram for this system is given in fig. Data are given below. Compute the fault current when a single line to ground fault occurs at the middle of the line through a fault resistance of 4.033 ohm.



Data:

$G_1$  &  $G_2$  : 11 KV, 100 MVA,  $x_{g1} = 0.20$  pu,  $x_{g2} = x_{g0} = 0.10$  pu  
 $T_1$  : 180 MVA, 11.5/115 KV,  $x_{T1} = 0.10$  pu  
 $T_2$  : 170 MVA, 6.6/115 KV,  $x_{T2} = 0.10$  pu  
 $M$  : 6.3 KV, 160 MVA,  $x_{m1} = x_{m2} = 0.30$  pu,  $x_{m0} = 0.10$  pu

Line :

$$x_{Line1} = x_{Line2} = 30.25 \text{ ohm}, x_{Line0} = 60.5 \text{ ohm}$$

Solution:

Let Base MVA = 100, Base KV = 11

∴ Base voltage of transmission line would be

$$\left(\frac{115}{11.5}\right) \times 11 = 110 \text{ KV.}$$

$$\therefore x_{T1} = 0.1 \times \frac{100}{180} \times \left(\frac{115}{11}\right)^2 = 0.061 \text{ pu}$$

$$x_{T2} = 0.1 \times \frac{100}{170} \times \left(\frac{115}{11}\right)^2 = 0.064 \text{ pu}$$

$$\text{Transmission line base impedance} = \frac{(110)^2}{100} = 121 \text{ ohm.}$$

$$\therefore x_{Line1} = x_{Line2} = \frac{30.25}{121} = 0.25 \text{ pu}$$

$$x_{Line0} = \frac{60.5}{121} = 0.5 \text{ pu}$$

$$\text{Motor side base voltage} = 110 \times \frac{6.6}{115} = 6.313 \text{ KV.}$$

$$\therefore x_{m1} = x_{m2} = 0.3 \times \frac{100}{160} \times \left(\frac{6.3}{6.313}\right)^2 = 0.187 \text{ pu}$$

$$x_{m0} = 0.1 \times \frac{100}{160} \times \left(\frac{6.3}{6.313}\right)^2 = 0.062 \text{ pu}$$

**Prefault Condition**

Load supplied = 60 MW at 0.8 pf (lagging)

$$= \frac{60}{0.8} = 75 \text{ MVA} = \frac{75}{100} \text{ pu} = 0.75 \text{ pu}$$

Motor Voltage

$$E_m = \frac{6.0}{6.313} \angle 0^\circ = 0.95 \angle 0^\circ \text{ pu}$$

$$I_m = \frac{0.75}{0.95} \angle -36.9^\circ = 0.789 (0.8 - j0.6) \text{ pu.}$$

Prefault voltage at the mid point of the line

$$V_f = V_m + I (j0.125 + j0.064 + j0.187)$$

$$\therefore V_f = 0.95 \angle 0^\circ + 0.789(0.8 - j0.6)(j0.376)$$

$$\therefore V_f = 1.153 \angle 11.90^\circ \text{ pu}$$

Fig. 10.21(a) shows the positive sequence network

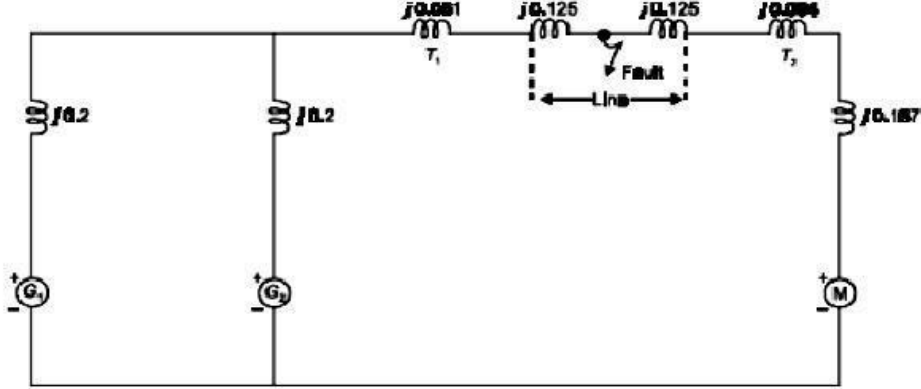


Fig. 10.21(b) and Fig. 10.21(c) gives the negative and zero-sequence network connection.

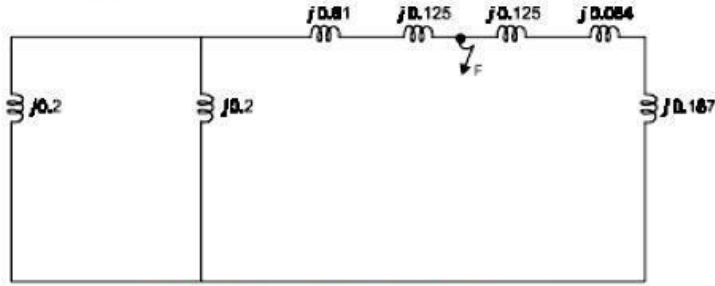


Fig. 10.21(b): Negative sequence network.

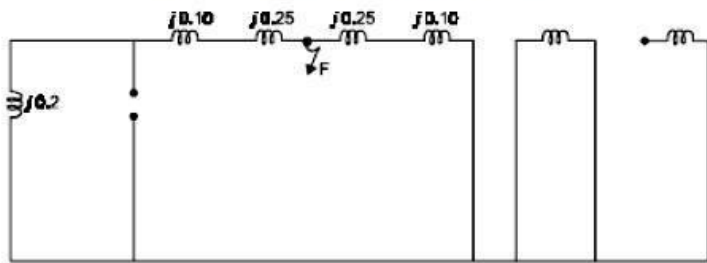


Fig.10.21(c): Zero-sequence network.

After step by step reduction of positive, negative and zero-sequence network, interconnection among them is shown in Fig. 10.22.

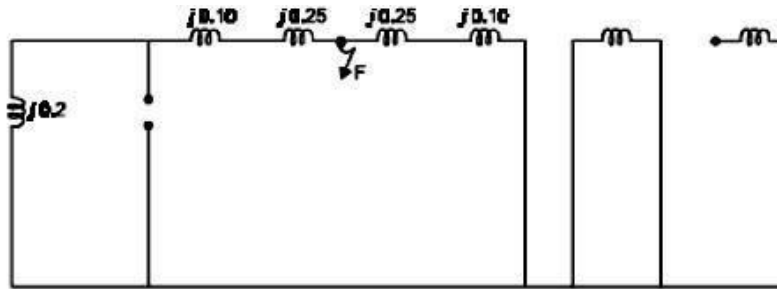


Fig.10.21(c): Zero-sequence network.

After step by step reduction of positive, negative and zero-sequence network, interconnection among them is shown in Fig. 10.22.

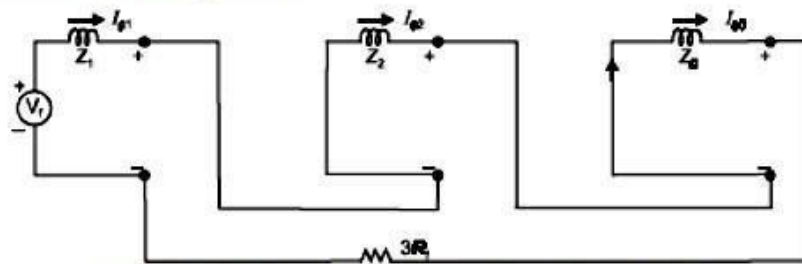


Fig. 10.22: Sequence network connection of Example 10.9.

where

$$Z_1 = j0.162 \text{ pu}, \quad Z_2 = j0.162 \text{ pu}, \quad Z_0 = j0.197 \text{ pu}$$

$$R_f = 4.033 \text{ ohm.} = \frac{4.033}{121} = 0.0333 \text{ pu.}$$

∴

$$3 R_f = 0.10 \text{ pu.}$$

$$I_{a1} = I_{a2} = I_{a0} = I_f/3$$

we know fault current

$$\therefore I_f = \frac{3V_f}{Z_1 + Z_2 + Z_0 + 3R_f}$$

$$\therefore I_f = \frac{3 \times 1.153 \angle 11.90}{j0.162 + j0.162 + j0.197 + 0.10}$$

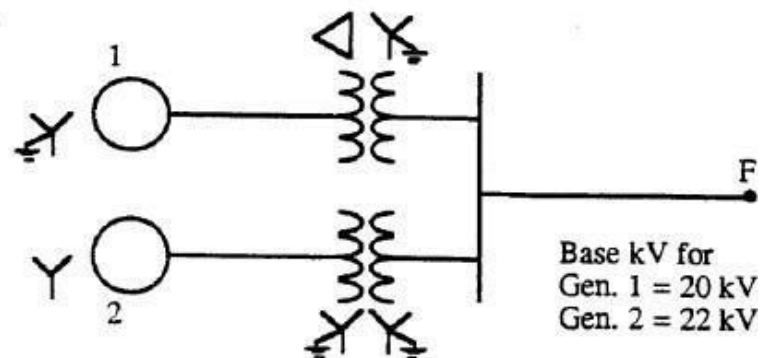
$$\therefore |I_f| = 6.514 \text{ pu} = 6514 \times \frac{100}{\sqrt{3} \times 110} \text{ KA} \\ = 3.418 \text{ KA Ans.}$$

Two generators  $G_1$  and  $G_2$  are connected respectively through transformers  $T_1$  and  $T_2$  to a high-voltage bus which supplies a transmission line. The line is open at the far end at which point  $F$  a fault occurs. The prefault voltage at point  $F$  is 515 kV. Apparatus ratings and reactances are

$G_1$	1000 MVA, 20 kV, $X_s = 100\%$	$X_d'' = X_1 = X_2 = 10\%$	$X_0 = 5\%$
$G_2$	800 MVA, 22 kV, $X_s = 120\%$	$X_d'' = X_1 = X_2 = 15\%$	$X_0 = 8\%$
$T_1$	1000 MVA, 500Y/20 $\Delta$ kV, $X = 17.5\%$		
$T_2$	800 MVA, 500Y/22Y kV, $X = 16.0\%$		
Line	$X_1 = 15\%$ , $X_0 = 40\%$ on a base of 1500 MVA, 500 kV		

The neutral of  $G_1$  is grounded through a reactance of  $0.04 \Omega$ . The neutral of  $G_2$  is not grounded. Neutrals of all transformers are solidly grounded. Work on a base of 1000 MVA, 500 kV in the transmission line. Neglect prefault current and find subtransient current (a) in phase  $c$  of  $G_1$  for a three-phase fault at  $F$ , (b) in phase  $B$  at  $F$  for a line-to-line fault on lines  $B$  and  $C$ , (c) in phase  $A$  at  $F$  for a line-to-ground fault on line  $A$  and (d) in phase  $c$  of  $G_2$  for a line-to-ground fault on line  $A$ . Assume  $V_A^{(1)}$  leads  $V_a^{(1)}$  by  $30^\circ$  in  $T_1$ .

Solution:

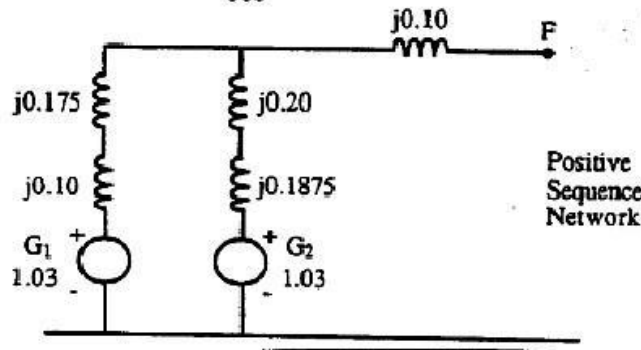


The base currents are calculated as

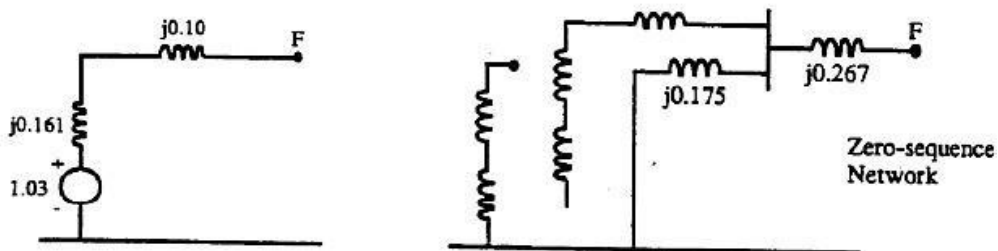
$$\begin{aligned} \text{Line: } & \frac{1,000,000}{\sqrt{3} \times 500} = 1155 \text{ A} \\ \text{Gen. 1: } & \frac{1,000,000}{\sqrt{3} \times 20} = 28,868 \text{ A} \\ \text{Gen. 2: } & \frac{1,000,000}{\sqrt{3} \times 22} = 26,243 \text{ A} \end{aligned}$$

Impedances in per unit are

$$\begin{aligned} \text{Gen. 1: } & X_d'' = X_2 = 0.10 \quad X_0 = 0.05 \\ \text{Gen. 2: } & X_d'' = X_2 = 0.15 \times \frac{1000}{800} = 0.1875 \\ T_1: & X = 0.175 \quad T_2: X = 0.16 \times \frac{1000}{800} = 0.20 \\ \text{Line: } & X_1 = X_2 = 0.15 \times \frac{1000}{1500} = 0.10 \\ & X_0 = 0.40 \times \frac{1000}{1500} = 0.267 \\ \text{Operating voltage} & = \frac{515}{500} = 1.03 \text{ per unit} \end{aligned}$$



The above network reduces to



(a) Three-phase fault at F

$$\begin{aligned} I_A^{(1)} &= \frac{1.03}{j0.261} = -j3.946 \text{ per unit} \\ \text{In Gen. 1: } I_a^{(1)} &= \left( -j3.946 \frac{j0.3875}{j0.275 + j0.3875} \right) e^{-j30^\circ} = 2.308 \angle -120^\circ \text{ per unit} \\ I_c &= 2.308 \angle 0^\circ \text{ per unit} \end{aligned}$$

In all three phases  $|I_f''| = 2.308 \times 28.868 = 66,630 \text{ A}$ .

(b) Line-to-line fault at F ( $Z_1 = Z_2$ )

$$I_A^{(1)} = -I_A^{(2)} = \frac{1.03}{2(j0.261)} = -j1.973 \text{ per unit}$$

$$I_B = (a^2 - a) I_A^{(1)} = -j\sqrt{3}(-j1.973) = 3.417 \angle 180^\circ \text{ per unit}$$

$$|I_B''| = 3.417 \times 1155 = 3947 \text{ A}$$

(c) Single line-to-ground fault at F

$$I_A^{(1)} = \frac{1.03}{j0.261 + j0.261 + j0.175 + j0.267} = -j1.068 \text{ per unit}$$

$$|I_A''| = 3(1.068) \times 1155 = 3700 \text{ A}$$

(d) Single line-to-ground fault at F

$$\text{In Gen. 2: } I_a^{(1)} = I_a^{(2)} \quad I_a^{(0)} = 0$$

$$I_a^{(1)} = -j1.068 \frac{j0.275}{j0.275 + j0.3875} = -j0.443 \text{ per unit}$$

$$I_c = 0.443 \angle 120^\circ - 90^\circ + 0.443 \angle 240^\circ - 90^\circ$$

$$= 0.384 + j0.222 - 0.384 + j0.222 = j0.444 \text{ per unit}$$

$$|I_c''| = 0.444 \times 26,243 = 11,652 \text{ A}$$

**UNIT V STABILITY ANALYSIS**

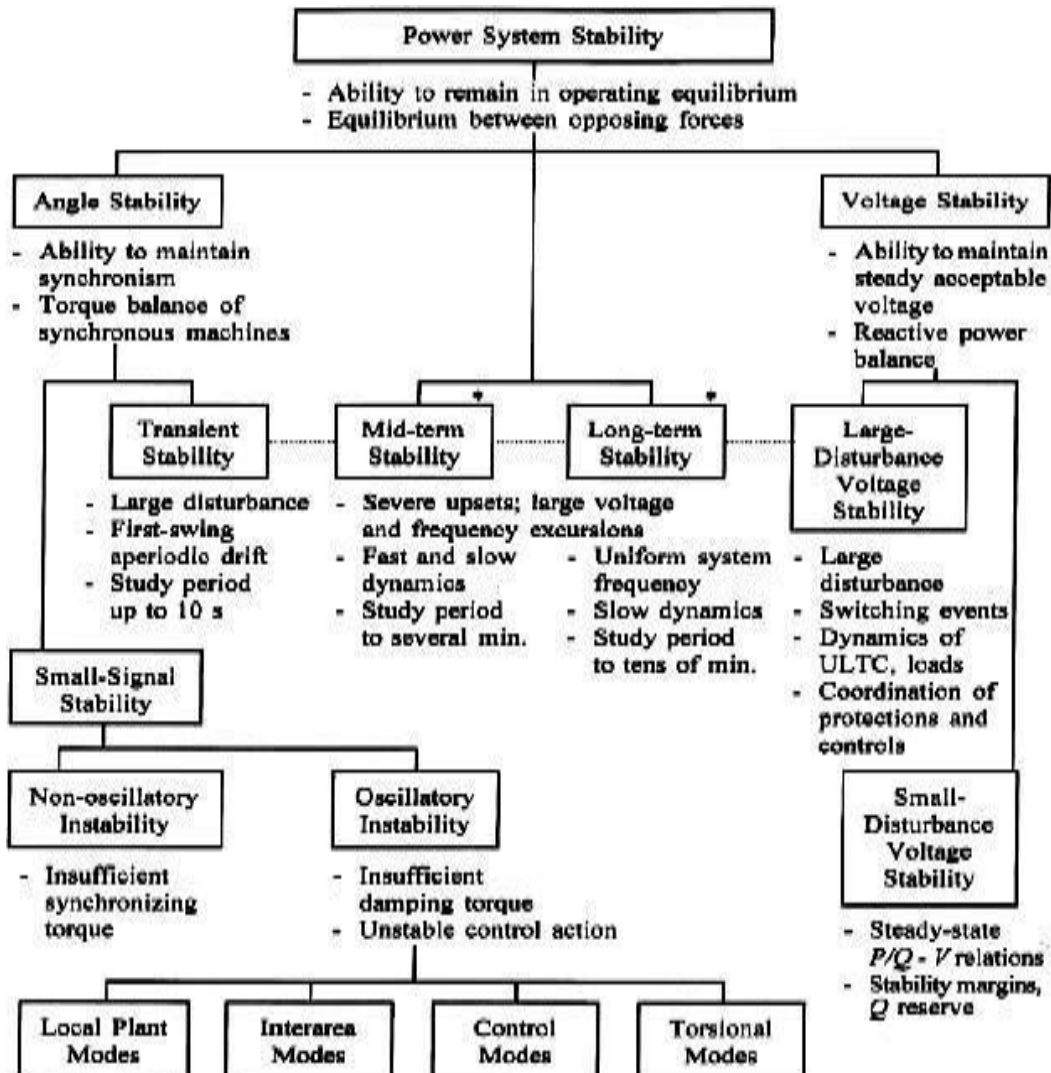
**IMPORTANCE OF STABILITY ANALYSIS IN POWER SYSTEM PLANNING AND OPERATION**

**Power system stability**

The stability of an interconnected power system means is the ability of the power system is to return or regain to normal or stable operating condition after having been subjected to some form of disturbance.

**CLASSIFICATION OF POWER SYSTEM STABILITY - ANGLE AND VOLTAGE STABILITY**

Power system stability is classified





## ANGLE AND VOLTAGE STABILITY

### Rotor angle stability

Rotor angle stability is the ability of interconnected synchronous machines of a power system to remain in synchronism.

### Steady state stability

Steady state stability is defined as the ability of the power system to bring it to a stable condition or remain in synchronism after a small disturbance.

### Steady state stability limit

The steady state stability limit is the maximum power that can be transferred by a machine to receiving system without loss of synchronism

### Transient stability

Transient stability is defined as the ability of the power system to bring it to a stable condition or remain in synchronism after a large disturbance.

### Transient stability limit

The transient stability limit is the maximum power that can be transferred by a machine to a fault or a receiving system during a transient state without loss of synchronism. Transient stability limit is always less than steady state stability limit

### Dynamic stability

It is the ability of a power system to remain in synchronism after the initial swing (transient stability period) until the system has settled down to the new steady state equilibrium condition

### Voltage stability

It is the ability of a power system to maintain steady acceptable voltages at all buses in the system under normal operating conditions and after being subjected to a disturbance.

### Causes of voltage instability

A system enters a state of voltage instability when a disturbance, increase in load demand, or change in system condition causes a progressive and uncontrollable drop in voltage. The main factor causing instability is the inability of the power system to meet the demand for reactive power.

Determination of critical clearing angle and time

### Power angle equation and draw the power angle curve

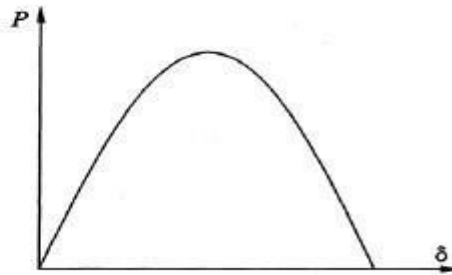
$$P = \frac{V_s V_r}{X_T} \sin \delta$$

Where, P – Real Power in watts

$V_s$  – Sending end voltage;  $V_r$  – Receiving end voltage

$X_T$  - Total reactance between sending end receiving end

$\delta$  - Rotor angle.

**Power angle curve**

**Maximum power transfer.**

$$P_{max} = \frac{V_s V_r}{X_T}$$

**Swing equation for a SMIB (Single machine connected to an infinite bus bar) system.**

$$\frac{H}{\pi f} \frac{d^2 \delta}{dt^2} = P_m - P_e$$

Since  $M$  in p.u =  $H/\pi f$

$$M \frac{d^2 \delta}{dt^2} = P_m - P_e$$

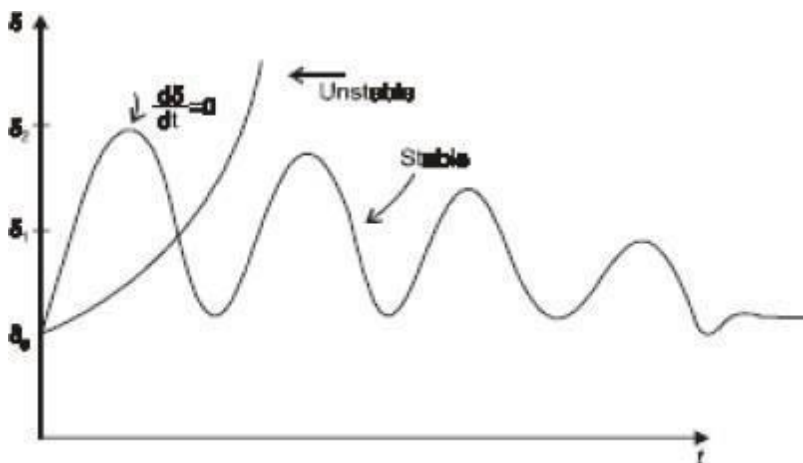
Where  $H$  = inertia constant in MW/MVA

$f$  = frequency in Hz

$M$  = inertia constant in p.u

**Swing curve**

The swing curve is the plot or graph between the power angle  $\delta$  and time  $t$ . From the nature of variations of  $\delta$  the stability of a system for any disturbance can be determined.



**3 machine system having ratings  $G_1$ ,  $G_2$  and  $G_3$  and inertia constants  $M_1$ ,  $M_2$  and  $M_3$ . What is the inertia constants  $M$  and  $H$  of the equivalent system.**

$$M_{eq} = \frac{M_1 G_1}{G_b} + \frac{M_2 G_2}{G_b} + \frac{M_3 G_3}{G_b}$$

$$H_{eq} = \frac{\pi f M_{eq}}{G_b}$$

Where  $G_1, G_2, G_3$  – MVA rating of machines 1, 2, and 3  
 $G_b$  = Base MVA or system MVA

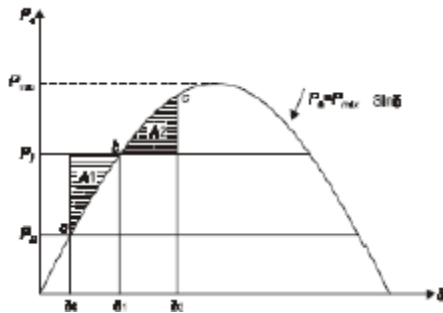
### Assumptions made in stability studies.

- (i). Machines represents by classical model
- (ii). The losses in the system are neglected (all resistance are neglected)
- (iii). The voltage behind transient reactance is assumed to remain constant.
- (iv). Controllers are not considered ( Shunt and series capacitor )
- (v). Effect of damper winding is neglected.

### Equal Area Criterion

The equal area criterion for stability states that the system is stable if the area under  $P - \delta$  curve reduces to zero at some value of  $\delta$ .

This is possible if the positive (accelerating) area under  $P - \delta$  curve is equal to the negative (decelerating) area under  $P - \delta$  curve for a finite change in  $\delta$ . hence stability criterion is called equal area criterion.



### Critical clearing angle.

The critical clearing angle, is the maximum allowable change in the power angle  $\delta$  before clearing the fault, without loss of synchronism.

The time corresponding to this angle is called critical clearing time, .It can be defined as the maximum time delay that can be allowed to clear a fault without loss of synchronism.

### Methods of improving the transient stability limit of a power system.

- (i).Reduction in system transfer reactance
- (ii).Increase of system voltage and use AVR
- (iii).Use of high speed excitation systems
- (iv). Use of high speed reclosing breakers

### Numerical integration methods of power system stability

- i. Point by point method or step by step method
- ii. Euler method
- iii. Modified Euler method
- iv. Runge-Kutta method(R-K method)

## SINGLE MACHINE INFINITE BUS (SMIB) SYSTEM: DEVELOPMENT OF SWING EQUATION.

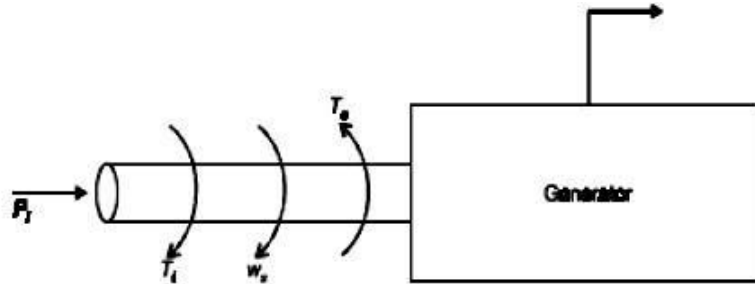


Fig. 11.1: Flow of powers in a synchronous generator.

Consider a synchronous generator developing an electromagnetic torque  $T_e$  (and a corresponding electromagnetic power  $P_e$ ) while operating at the synchronous speed  $w_s$ . If the input torque provided by the prime mover, at the generator shaft is  $T_i$ , then under steady-state conditions (i.e., without any disturbance)

$$T_e = T_i \quad \dots(11.10)$$

Here we have neglected any retarding torque due to rotational losses. Therefore we have

$$T_e w_s = T_i w_s \quad \dots(11.11)$$

and  $T_i w_s - T_e w_s = P_i - P_e = 0 \quad \dots(11.12)$

If there is a departure from steady-state occurs, for example, a change in load or a fault, then input power  $P_i$  is not equal to  $P_e$  if the armature resistance is neglected. Therefore left-side of eqn. (11.12) is not zero and an accelerating torque comes into play. If  $P_a$  is the corresponding accelerating (or decelerating) power, then

$$P_i - P_e = M \cdot \frac{d^2\theta_e}{dt^2} + D \cdot \frac{d\theta_e}{dt} = P_a \quad \dots(11.13)$$

Where  $M$  has been defined in eqn. (11.8) or eqn. (11.9).  $D$  is a damping coefficient and  $\theta_e$  is the electrical angular position of the rotor. It is more convenient to measure the angular position of the rotor with respect to a synchronously rotating frame of reference. Let

$$\delta = \theta_e - w_s \cdot t \quad \dots(11.14)$$

$$\therefore \frac{d^2\theta_e}{dt^2} = \frac{d^2\delta}{dt^2} \quad \dots(11.15)$$

Where  $\delta$  is the power angle of the synchronous machine. Neglecting damping (i.e.,  $D = 0$ ) and substituting eqn. (11.15) in eqn. (11.13), we get,

$$M \cdot \frac{d^2\delta}{dt^2} = P_i - P_e \text{ MW} \quad \dots(11.16)$$

$$\frac{GH}{\pi f} \frac{d^2\delta}{dt^2} = P_i - P_e \text{ MW} \quad \dots(11.17)$$

Dividing throughout by  $G$ , the MVA rating of the machine,

$$M(\text{pu}) \frac{d^2\delta}{dt^2} = (P_i - P_e) \text{ pu} \quad \dots(11.18)$$

where  $M(\text{pu}) = \frac{H}{\pi f} \quad \dots(11.19)$

or  $\frac{H}{\pi f} \frac{d^2\delta}{dt^2} = (P_i - P_e) \text{ pu} \quad \dots(11.20)$

Eqn. (11.20) is called swing equation. It describes the rotor dynamics for a synchronous machine. Although damping is ignored but it helps to stabilize the system. Damping must be considered in dynamic stability study.

A 400 MVA synchronous machine has  $H_1=4.6$  MJ/MVA and a 1200 MVA machines  $H_2=3.0$  MJ/MVA. Two machines operate in parallel in a power plant. Find out  $H_{eq}$  relative to a 100MVA base.

### Solutions:

Total kinetic energy of the two machines is

$$KE = 4.6 \times 400 + 3 \times 1200 = 5440 \text{ MJ.}$$

Using the formula given in eqn. (11.28),

$$H_{eq} = \left( \frac{400}{100} \right) \times 4.6 + \left( \frac{1200}{100} \right) \times 3$$

$$\therefore H_{eq} = 54.4 \text{ MJ/MVA}$$

or, equivalent inertia relative to a 100 MVA base is

$$H_{eq} = \frac{KE}{\text{System base}} = \frac{5440}{100} = 54.4 \text{ MJ/MVA} \quad \text{Ans.}$$

A 100 MVA, two pole, 50Hz generator has moment of inertia  $40 \times 10^3$  kg-m<sup>2</sup>. what is the energy stored in the rotor at the rated speed? What is the corresponding angular momentum? Determine the inertia constant  $h$ .

**Solution:**

$$\eta_s = \frac{120f}{P} = \frac{120 \times 50}{2} = 3000 \text{ rpm.}$$

The stored energy is

$$\begin{aligned} \text{KE (stored)} &= \frac{1}{2} J \omega_m^2 = \frac{1}{2} (40 \times 10^3) \left( \frac{2\pi \times 3000}{50} \right)^2 \text{ MJ} \\ &= 2842.4 \text{ MJ} \end{aligned}$$

Then

$$H = \frac{\text{KE (stored)}}{\text{MVA}} = \frac{2842.4}{100} = 28.424 \text{ MJ/MVA.}$$

$$M = J \omega_m = (40 \times 10^3) \left( \frac{2\pi \times 3000}{50} \right)$$

$$\therefore \quad M = 15.07 \text{ MJ-Sec/mech-radian} \quad \text{Ans.}$$

The sending end and receiving end voltages of a three phase transmission line at a 200MW load are equal at 230KV. The per phase line impedance is j14 ohm. Calculate the maximum steady state power that can be transmitted over the line.

**Solution:**

$$\begin{aligned} |V_S| &= |V_R| = 230 \times 1000 / \sqrt{3} = 132790.5 \text{ Volt.} \\ &= 132.79 \text{ KV.} \end{aligned}$$

From eqn. (11.37)

$$\begin{aligned} P_R (\text{max}) = P_S (\text{max}) &= \frac{|V_S| |V_R|}{x} = \frac{|V_R|^2}{x} = \frac{(132.79)^2}{14} \\ &= 1259.5 \text{ MW/phase} \\ &= 3 \times 1259.5 \text{ MW (3- phase total)} \\ &= 3778.5 \text{ MW} \quad \text{Ans.} \end{aligned}$$

**Equal area criterion in transient stability.**

system. However, solution of swing equation is not always necessary to investigate the system stability. Rather, in some cases, a direct approach may be taken. Such an approach is based on the equal-area criterion.

Now consider eqn. (11.18),

$$\frac{Md^2\delta}{dt^2} = P_i - P_e$$

$$\therefore \frac{Md^2\delta}{dt^2} = P_a$$

$$\therefore \frac{d^2\delta}{dt^2} = \frac{P_a}{M} \quad \dots(11.39)$$

As is shown in Fig.11.6, in an unstable system,  $\delta$  increases indefinitely with time and machine loses synchronism. In a stable system,  $\delta$  undergoes oscillations, which eventually die out due to damping. From Fig. 11.6, it is clear that, for a system to be stable, it must be that

$\frac{d\delta}{dt} = 0$  at some instant. This criterion  $\left(\frac{d\delta}{dt} = 0\right)$  can simply be obtained from eqn. (11.39).

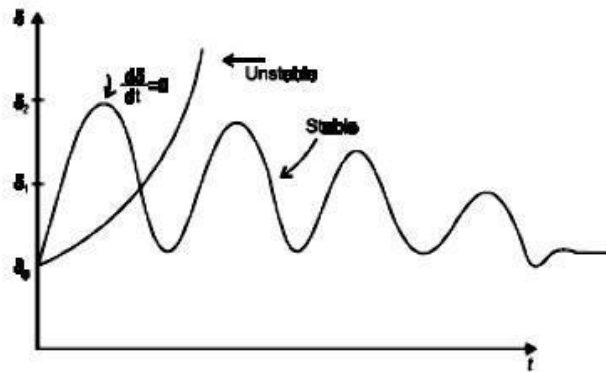


Fig. 11.6: A plot of  $\delta(t)$ .

Multiplying eqn. (11.39) by  $\frac{2d\delta}{dt}$ , we have

$$\frac{2d\delta}{dt} \cdot \frac{d^2\delta}{dt^2} = \frac{2P_a}{M} \frac{d\delta}{dt} \quad \dots(11.40)$$

which, upon integration with respect to time, gives

$$\left(\frac{d\delta}{dt}\right)^2 = \frac{2}{M} \int_{\delta_0}^{\delta} P_a d\delta \quad \dots(11.41)$$

Note that  $P_a = P_i - P_e =$  accelerating power and  $\delta_0$  is the initial power angle before the rotor begins to swing because of a disturbance. The stability criterion  $\frac{d\delta}{dt} = 0$  (at some moment) implies that

$$\int_{\delta_0}^{\delta} P_a d\delta = 0 \quad \dots(11.42)$$

This condition requires that, for stability, the area under the graph of accelerating power  $P_a$  versus  $\delta$  must be zero for some value of  $\delta$ ; that is, the positive (or accelerating) area under the graph must be equal to the negative (or decelerating) area. This criterion is therefore known as the equal-area criterion for stability and it is shown in Fig. 11.7.

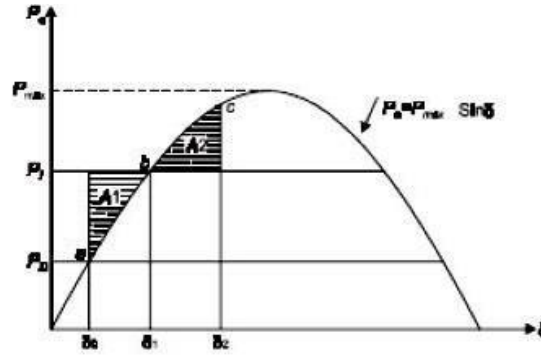


Fig. 11.7: Power angle characteristic.

In Fig.11.7, point 'a' corresponding to the  $\delta_0$  is the initial steady-state operating point. At this point, the input power to the machine,  $P_{i0} = P_{e0}$ . Where  $P_{e0}$  is the developed power. When a sudden increase in shaft input power occurs to  $P_1$ , the accelerating power,  $P_a$ , becomes positive and the rotor moves towards point 'b'. We have assumed that the machine is connected to a large power system so that  $|V_1|$  does not change and also that  $x_d$  does not change and that a constant field current maintains  $|E_f|$  constant. Consequently, the rotor accelerates and the

In Fig.11.7, point 'a' corresponding to the  $\delta_0$  is the initial steady-state operating point. At this point, the input power to the machine,  $P_{i0} = P_{e0}$ . Where  $P_{e0}$  is the developed power. When a sudden increase in shaft input power occurs to  $P_1$ , the accelerating power,  $P_a$ , becomes positive and the rotor moves towards point 'b'. We have assumed that the machine is connected to a large power system so that  $|V_1|$  does not change and also that  $x_d$  does not change and that a constant field current maintains  $|E_f|$  constant. Consequently, the rotor accelerates and the power angle begins to increase. At point 'b',  $P_i = P_e$  and  $\delta = \delta_1$ . But  $\frac{d\delta}{dt}$  is still positive and  $\delta$  overshoots 'b', the final steady-state operating point. Now  $P_a$  is negative and  $\delta$  ultimately reaches a maximum value  $\delta_2$ , or point 'c' and then swing back towards 'b'. Therefore, the rotor settles to the point 'b', which is ultimate steady-state stable operating point as shown in Fig. 11.7. In accordance with eqn. (11.42), the equal-area criterion requires that, for stability,

$$\text{Area } A1 = \text{Area } A2$$

$$\text{or} \quad \int_{\delta_0}^{\delta_1} (P_1 - P_{\max} \sin \delta) d\delta = \int_{\delta_1}^{\delta_2} (P_{\max} \sin \delta - P_1) d\delta \quad \dots(11.43)$$

$$\text{or} \quad P_1 (\delta_1 - \delta_0) + P_{\max} (\cos \delta_1 - \cos \delta_0) = P_1 (\delta_1 - \delta_2) + P_{\max} (\cos \delta_1 - \cos \delta_2) \quad \dots(11.44)$$

But  $P_1 = P_{\max} \sin \delta_1$ , which when substituted in eqn. (11.44), we get

$$P_{\max} (\delta_1 - \delta_0) \sin \delta_1 + P_{\max} (\cos \delta_1 - \cos \delta_0) = P_{\max} (\delta_1 - \delta_2) \sin \delta_1 + P_{\max} (\cos \delta_1 - \cos \delta_2) \quad \dots(11.45)$$

Upon simplification, eqn. (11.45) becomes

$$(\delta_2 - \delta_0) \sin \delta_1 + \cos \delta_2 - \cos \delta_0 = 0 \quad \dots(11.46)$$

A single line diagram of a system is shown in fig. All the values are in per unit on a common base. The power delivered into bus 2 is 1.0 p.u at 0.80 power factor lagging. Obtain the power angle equation and the swing equation for the system. Neglect all losses.



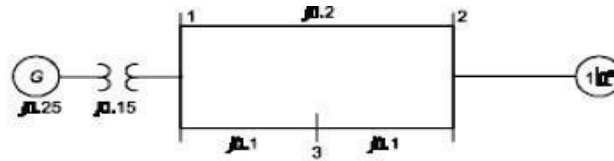


Fig. 11.3: Single line diagram of Example 11.5.

**Solution:**

Fig. 11.4 shows equivalent impedance diagram.

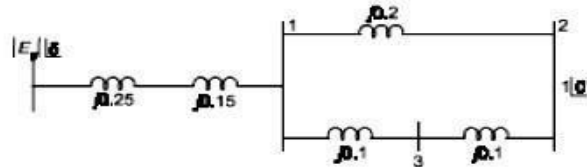


Fig. 11.4: Equivalent impedance diagram.

$$x_{eq} = 0.25 + 0.15 + \frac{0.2 \times 0.2}{0.4} = 0.50 \text{ pu}$$

$$\cos \Phi = 0.8, \Phi = 36.87^\circ \text{ (lagging)}$$

current into bus 2 is

$$I = \frac{1.0}{1 \times 0.8} \angle -36.87^\circ = 1.25 \angle -36.87^\circ \text{ pu}$$

The voltage  $E_g$  is then given by

$$|E_g| \angle \delta = |V_2| \angle 0^\circ + jx_{eq} I$$

$$\therefore |E_g| \angle \delta = 1 \angle 0^\circ + 0.5 \angle 90^\circ \times 1.25 \angle -36.87^\circ$$

$$\therefore |E_g| \angle \delta = 1 + 0.625 \angle 53.13^\circ$$

$$\therefore |E_g| \angle \delta = 1.375 + j 0.5$$

$$\therefore |E_g| \angle \delta = 1.463 \angle 20^\circ$$

$$\therefore |E_g| = 1.463, \delta = 20^\circ$$

$$\therefore P_e = \frac{E_g \cdot V_2}{x_{eq}} \sin \delta = \frac{1.463 \times 1}{0.5} \sin(\delta)$$

$$\therefore P_e = 2.926 \sin \delta$$

From eqn. (11.20),

$$\frac{H}{\pi f} \frac{d^2\delta}{dt^2} = P_i - P_e \quad \dots(i)$$

If it is desired to work in electrical degrees, then eqn. (i) can be written as

$$\frac{H}{180f} \frac{d^2\delta}{dt^2} = P_i - P_e \quad \dots(ii)$$

Here  $P_i = 1.0$  pu mechanical power input to the generator.

$$\therefore \frac{H}{180f} \frac{d^2\delta}{dt^2} = 1 - 2.926 \sin \delta \quad \text{Ans.}$$

As a verification of the result, at steady-state

$$P_i = P_e = 1 \quad \therefore 2.926 \sin \delta = 1 \quad \therefore \delta = 20^\circ$$

**CRITICAL CLEARING ANGLE AND CRITICAL CLEARING TIME IN TRANSIENT STABILITY.**

If a fault occurs in a system,  $\delta$  begins to increase under the influence of positive accelerating power, and the system will become unstable if  $\delta$  becomes very large. There is a critical angle within which the fault must be cleared if the system is to remain stable and the equal-area criterion is to be satisfied. This angle is known as the critical clearing angle. Consider the system of Fig. 11.9 operating with mechanical input  $P_i$  at steady angle  $\delta_0$  ( $P_i = P_e$ ) as shown by the point 'a' on the power angle diagram of Fig. 11.10.

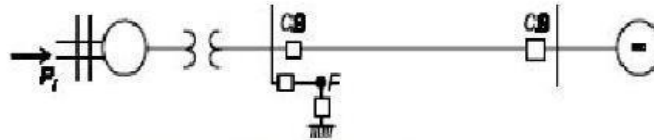


Fig. 11.9: Single machine infinite bus system.

Now if a three phase short circuit occurs at the point  $F$  of the outgoing radial line, the terminal voltage goes to zero and hence the electrical power output of the generator instantly reduces to zero, i.e.,  $P_e = 0$  and the state point drops to 'b'. The acceleration area  $A_1$  starts to increase while the state point moves along  $bc$ . At time  $t_c$  corresponding clearing angle  $\delta_c$  the fault is cleared by the opening of the line circuit breaker.  $t_c$  is called clearing time and  $\delta_c$  is called clearing angle. After the fault is cleared, the system again becomes healthy and transmits power  $P_e = P_{max} \sin \delta$ , i.e., the state point shifts to "d" on the power angle curve. The rotor now decelerates and the decelerating area  $A_2$  begins to increase while the state point moves along  $de$ .

For stability, the clearing angle,  $\delta_c$  must be such that area  $A_1 = \text{area } A_2$ .

Expressing area  $A_1 = \text{area } A_2$  mathematically, we have

$$P_i (\delta_c - \delta_0) = \int_{\delta_c}^{\delta_1} (P_c - P_i) d\delta$$

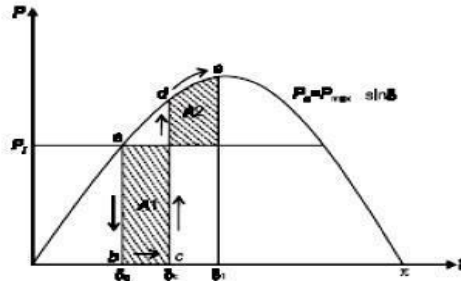


Fig. 11.10:  $P_e - \delta$  characteristic.

$$\begin{aligned} \therefore P_i(\delta_c - \delta_0) &= \int_{\delta_c}^{\delta_1} P_{\max} \sin \delta \cdot d\delta - P_i(\delta_1 - \delta_c) \\ \therefore P_i\delta_c - P_i\delta_0 &= P_{\max}(-\cos\delta_1 + \cos\delta_0) - P_i\delta_1 + P_i\delta_c \\ \therefore P_{\max}(\cos\delta_c - \cos\delta_1) &= P_i(\delta_1 - \delta_0) \end{aligned} \quad \dots(11.47)$$

Also

$$P_i = P_{\max} \sin\delta_0 \quad \dots(11.48)$$

Using eqns. (11.47) and (11.48) we get

$$\begin{aligned} P_{\max}(\cos\delta_c - \cos\delta_1) &= P_{\max}(\delta_1 - \delta_0) \sin\delta_0 \\ \therefore \cos\delta_c &= \cos\delta_1 + (\delta_1 - \delta_0) \sin\delta_0 \end{aligned} \quad \dots(11.49)$$

To reiterate, with reference to Fig. 11.10, the various angles in eqn.(11.49) are:  $\delta_c$  = clearing angle;  $\delta_0$  = initial power angle; and  $\delta_1$  = power angle to which the rotor advances (or overshoots) beyond  $\delta_c$ .

In order to determine the clearing time, we re-write eqn.(11.20), with  $P_e = 0$ , since we have a three phase fault,

$$\frac{d^2\delta}{dt^2} = \frac{\pi f}{H} P_i \quad \dots(11.50)$$

Integrating eqn. (11.50) twice and utilizing the fact that when  $t = 0$ ,  $\frac{d\delta}{dt} = 0$  yields

$$\delta = \frac{\pi f P_i}{2H} t^2 + \delta_0 \quad \dots(11.51)$$

If  $t_c$  is a clearing time corresponding to a clearing angle  $\delta_c$ , then we obtain from eqn. (11.51),

$$\begin{aligned} \delta_c &= \frac{\pi f P_i}{2H} t_c^2 + \delta_0 \\ \therefore t_c &= \sqrt{\frac{2H(\delta_c - \delta_0)}{\pi f P_i}} \end{aligned} \quad \dots(11.52)$$

Note that  $\delta_c$  can be obtained from eqn. (11.49). As the clearing of the faulty line is delayed,  $A_1$  increases and so does  $\delta_1$  to find  $A_2 = A_1$  till  $\delta_1 = \delta_m$  as shown in Fig. 11.11. For a clearing

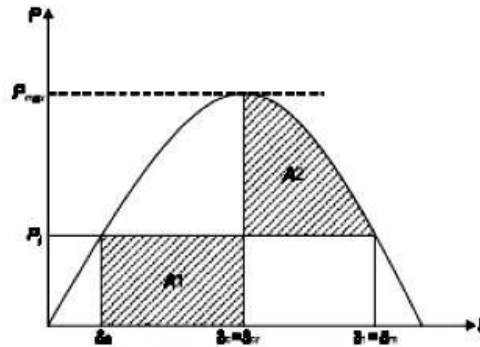


Fig. 11.11: Critical clearing angle.

angle (or clearing time) larger than this value, the system would be unstable. The maximum allowable value of the clearing angle and clearing time for the system to remain stable are known as critical clearing angle and critical clearing time respectively.

From Fig. 11.11,  $\delta_m = \pi - \delta_0$ , we have upon substitution into eqn. (11.49)

$$\begin{aligned} \cos\delta_{cr} &= \cos\delta_m + (\delta_m - \delta_0) \sin\delta_0 \\ \therefore \cos\delta_{cr} &= \cos\delta_m + (\pi - \delta_0 - \delta_0) \sin\delta_0 \\ \therefore \cos\delta_{cr} &= \cos(\pi - \delta_0) + (\pi - 2\delta_0) \sin\delta_0 \\ \therefore \cos\delta_{cr} &= (\pi - 2\delta_0) \sin\delta_0 - \cos\delta_0 \\ \therefore \delta_{cr} &= \cos^{-1}[(\pi - 2\delta_0) \sin\delta_0 - \cos\delta_0] \end{aligned} \quad \dots(11.53)$$

Using eqn. (11.52), critical clearing time can be written as:

$$t_{cr} = \sqrt{\frac{2H(\delta_{cr} - \delta_0)}{\pi f P_i}} \quad \dots(11.54)$$