

# **A Course Module**

**on**

**AC MACHINES**

**(20A02402T)**

**Prepared by**

**Dr.B.THRIVIKRAM**

**Assoc. Professor**

**Department of EEE**



**SREE RAMA ENGINEERING COLLEGE**

Approved by AICTE, New Delhi – Affiliated to JNTUA, Ananthapuramu

Accredited by NAAC with 'A' Grade

An ISO 9001:2015 & ISO 14001:2015 certified Institution

Rami Reddy Nagar, Karakambadi road, Tirupati-517507

**JAWAHARLAL NEHRU TECHNOLOGICAL UNIVERSITY ANANTAPUR**  
**(Established by Govt. of A.P., ACT No.30 of 2008)**  
**ANANTHAPURAMU – 515 002 (A.P) INDIA**



**ELECTRICAL AND ELECTRONICS ENGINEERING**

Course Code	AC MACHINES		L	T	P	C
20A02402T			3	0	0	3
Pre-requisite	Electrical circuits, Magnetic circuits, DC machines and transformers	Semester	IV			
<b>Course Objectives:</b>						
The students will be able to: <ul style="list-style-type: none"> <li>Understand the fundamentals of AC machines, know equivalent circuit performance characteristics.</li> <li>Understand the methods of starting of Induction motors.</li> <li>Understand the methods of starting of Synchronous motors.</li> <li>Understand the parallel operation of Alternators.</li> </ul>						
<b>Course Outcomes (CO):</b>						
At the end of this course, students will be able to: <ul style="list-style-type: none"> <li>Understand the basics of ac machine windings, construction, principle of working, equivalent circuit of induction and synchronous machines.</li> <li>Analyze the phasor diagrams of induction and synchronous machine, parallel operation of alternators, synchronization and load division of synchronous generators.</li> <li>Apply the concepts to determine V and inverted V curves and power circles of synchronous motor.</li> <li>Analyze the various methods of starting in both induction and synchronous machines.</li> </ul>						
UNIT - I	<b>Fundamentals of AC machine windings</b>	9Hrs				
Physical arrangement of windings in stator and cylindrical rotor; slots for windings; single turn coil - active portion and overhang; full-pitch coils, concentrated winding, distributed winding, winding axis, Air-gap MMF distribution with fixed current through winding - concentrated and distributed, Sinusoidally distributed winding, winding distribution factors.						
UNIT - II	<b>Induction Machines</b>	10 Hrs				
Operating principle, Construction, Types (squirrel cage and slip-ring), Starting and Maximum Torque, Equivalent circuit, Phasor Diagram, Torque-Slip Characteristics, power flow in induction machines, Losses and Efficiency, No load and blocked rotor test, Circle diagram, performance characteristics, Numerical problems. Methods of starting, braking and speed control for induction motors, Doubly-Fed Induction Machines, crawling and cogging. Analysis of 3 phase induction motors with single phasing operation.						
UNIT - III	<b>Synchronous generators</b>	10 Hrs				
Constructional features, cylindrical rotor synchronous machine - generated EMF, equivalent circuit and phasor diagram, armature reaction, synchronous impedance, voltage regulation, EMF, MMF, ZPF and ASA methods. Operating characteristics of synchronous machines, Salient pole machine - two reaction theory, analysis of phasor diagram, power angle characteristics. Parallel operation of alternators - synchronization and load division.						
UNIT - IV	<b>Synchronous motors</b>	10 Hrs				
Principle of operation, methods of starting, Phasor diagram of synchronous motor, variation of current and power factor with excitation, V and inverted V curves, Hunting and use of damper bars, Synchronous condenser and power factor correction, Excitation and power circles.						
UNIT - V	<b>Single-phase induction motors</b>	9 Hrs				
Constructional features, double revolving field theory, equivalent circuit, determination of parameters. Split-phase starting methods and its applications, capacitor start and run single phase						

**JAWAHARLAL NEHRU TECHNOLOGICAL UNIVERSITY ANANTAPUR**  
**(Established by Govt. of A.P., ACT No.30 of 2008)**  
**ANANTHAPURAMU – 515 002 (A.P) INDIA**



**ELECTRICAL AND ELECTRONICS ENGINEERING**

motors, reluctance single phase motors, stepper motors, BLDC motors.

**Textbooks:**

1. A. E. Fitzgerald and C. Kingsley, "Electric Machinery", McGraw Hill Education, 2013.
2. P. S. Bimbhra, "Electrical Machinery", Khanna Publishers, 2011.

**Reference Books:**

1. M. G. Say, "Performance and design of AC machines", CBS Publishers, 2002.
2. I. J. Nagrath and D. P. Kothari, "Electric Machines", McGraw Hill Education, 2010.
3. A. S. Langsdorf, "Alternating current machines", McGraw Hill Education, 1984.
4. P. C. Sen, "Principles of Electric Machines and Power Electronics", John Wiley & Sons, 2007.

**Online Learning Resources:**

- [https://onlinecourses.nptel.ac.in/noc21\\_ee13/preview](https://onlinecourses.nptel.ac.in/noc21_ee13/preview)

**AC MACHINES**  
**(20A02402T)**

**UNIT-I**

**Fundamentals of**  
**AC Machine Windings**

**LECTURE NOTES**

## UNIT – I

### Armature Windings in Alternator & Types of Armature Windings

#### What are Armature Windings?

The winding through which a current is passed to produce the main flux is called the field winding. The winding in which voltage is induced is called the armature winding.

For an alternator, the armature is kept stationary on the stator. The stationary armature has its several advantages over rotating armature. The armature winding is placed on the slots of the stator.

The armature winding of dc motor is of closed circuit type but in case of alternator, it is either closed giving delta connection or open giving star connection. But however, the general principles governing armature winding of dc machine and alternator are the same.

Some Basic terms related to the armature winding are defined as follows

**1) Conductor:** The part of the wire, which is under the influence of the magnetic field and responsible for the induced emf is called active length of the conductor. The conductors are placed in the armature slots.

**2) Turn:** A conductor in one slot, when connected to a conductor in another slot forms a turn. So two conductors constitute a turn. This is shown in the below figure (a).

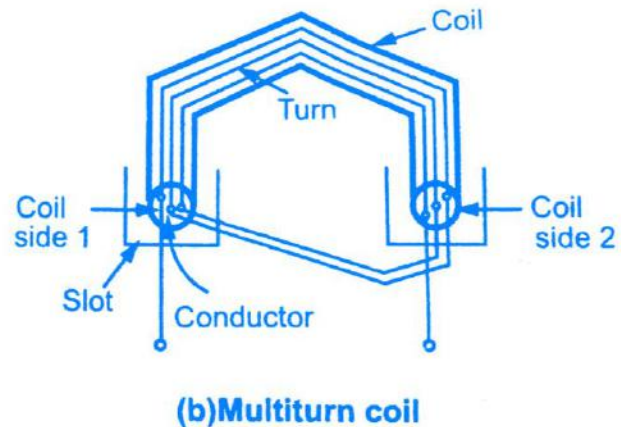
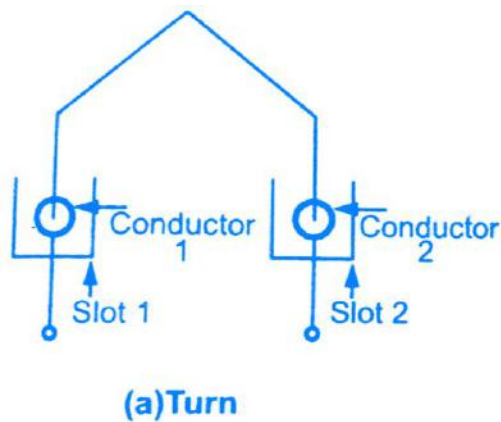

**3) Coil:** As there are a number of turns, for simplicity the number of turns are grouped together to form a coil. Such a coil is called a multi-turn coil. A coil may consist of single turn called single turn coil. Figure(b) shows a multi-turn coil.

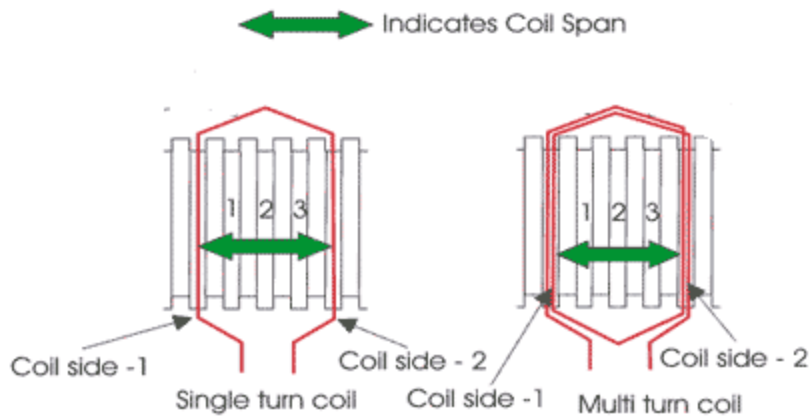

**4) Coil Side:** Coil consists of many turns. Part of the coil in each slot is called coil side of a coil as shown in the above figure(b).

**5) Pole Pitch:** It is centre to centre distance between the two adjacent poles. We have seen that for one rotation of the conductors, 2 poles are responsible for  $360^\circ$  electrical of emf, 4 poles are responsible for  $720^\circ$  electrical of emf and so on. So 1 pole is responsible for  $180^\circ$  electrical of induced emf.

**Key Point:** So  $180^\circ$  electrical is also called one pole pitch. Practically how many slots are under one pole which is responsible for  $180^\circ$  electrical, are measured to specify the pole pitch. For example let us consider 2 poles, 18 slots armature of an alternator. Then under slots are responsible for producing a phase difference of  $180^\circ$  between the emfs induced in different conductors.

This number of slots/pole is denoted as 'n'.

$$\begin{aligned}
 \text{Pole pitch} &= 180^\circ \text{ electrical} \\
 &= \text{slots per. Pole (no. of slots/P)} \\
 &= n
 \end{aligned}$$

**COIL PITCH :** The distance between the two sides of a coil is called the coil span or coil pitch.

A pole pitch always  $180^\circ$  electrical degrees regardless of the number of poles on the machine.

**6) Slot angle ( $\beta$ ):** The phase difference contributed by one slot in degrees electrical is called slot angle. As slots per pole contribute  $180^\circ$  electrical which is denoted as 'n', we can write,

$$1 \text{ slot angle} = 180^\circ/n$$

$$\beta = 180^\circ/n$$

In the above example,

$$n = 18/2 = 9, \text{ while } \beta = 180^\circ/n = 20^\circ$$

**Note:** This means that if we consider an induced e.m.f. in the conductors which are placed in the slots which are adjacent to each other, there will exist a phase difference of  $\beta$  between them. While if e.m.f. induced in the conductors which are placed in slots which are 'n' slots distance away, there will exist a phase difference of  $180^\circ$  between them.

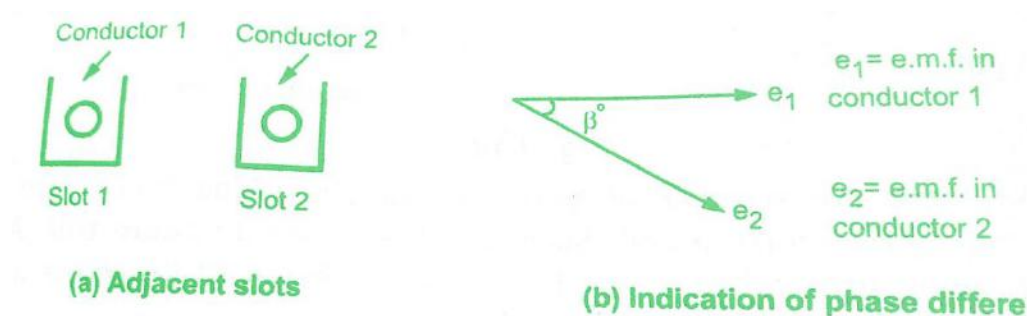

### Types of Armature Windings in Alternator:

The different types of armature windings in alternators are,

- 1) Single layer and double layer winding
- 2) Full pitch and short pitch winding
- 3) Concentrated and distributed winding

#### 1) Single Layer and Double Layer Winding:

If a slot consists of only one coil side, winding is said to be a single layer. This is shown in figure(a). While there are two coil sides per slot, one, at the bottom and one at the top the winding is called double layer as shown in figure(b). A lot of space gets wasted in single layer hence in practice generally double layer winding is preferred.

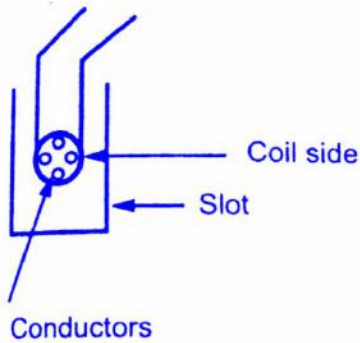

**(a) Single layer**

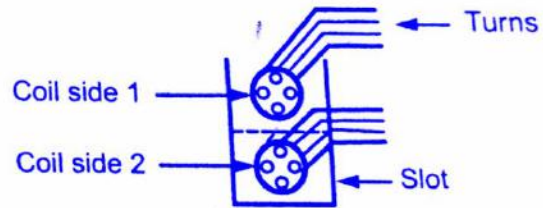

**(b) Double layer**

## 2) Full Pitch and Short Pitch Winding:

As seen earlier, one pole pitch is  $180^\circ$  electrical. The value of 'n', slots per pole indicates how many slots are contributing  $180^\circ$  electrical phase difference. So if coil side in one slot is connected to a coil side in another slot which is one pole pitch distance away from the first slot, the winding is said to be full pitch winding and coil is called full pitch coil.

i.e

$$\text{Coil Span} = \text{Pole pitch} = 180^\circ \text{ electrical} = \text{Slots} / \text{Poles} = \text{Full pitch coil}$$

For example, in 2 poles, 18 slots *alternator*, the pole pitch is  $n = 18/2 = 9$  slots.

So (1+9 = 10 Slot) if coil side in slot No. 1 is connected to coil side in slot No. 10 such that two slots No. 1 and No. 10 are one pole pitch or n slots or  $180^\circ$  electrical apart, the coil is called full pitch coil.

Here we can define one more term related to a coil called coil span.

### Coil Span:



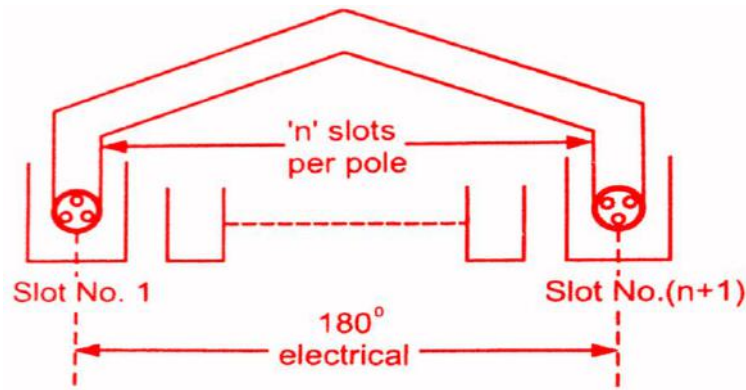

It is the distance on the periphery of the armature, between two coil sides of a coil. It is usually expressed in terms of number of slots or degrees electrical. So if coil span is 'n' slots or  $180^\circ$  electrical the coil is called  $180^\circ$  full pitch coil. This is shown in the figure to left. As against this if coils are used in such a way that coil span is slightly less than a pole pitch i.e. less than  $180^\circ$  electrical, the coils are called, short pitched coils or fractional pitched coils. Generally, coils are shorted by one or two slots.

Coil span =  $180^\circ - \alpha$  ( $\alpha$  is called **short pitch angle or chording angle**)

So in 18 slots, 2 pole alternator instead of connecting a coil side in slot No 1 to slot No.10, it is connected to a coil side in slot No.9 or slot No. 8, the coil is said to be short pitched coil and winding are called short pitch winding. This is shown in the below figure.

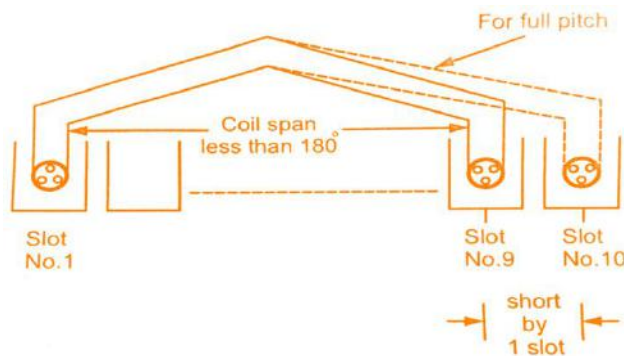

Fig: Short pitch coils

### Advantages of Short Pitch Coils:

In actual practice, short pitch coils are used as it has following advantages,

1) The length required for the end connections of coils is less i.e. the inactive length of winding is less. So less copper is required. Hence economical.

2) Short pitching eliminates high frequency harmonics which distort the sinusoidal nature of e.m.f. Hence waveform of an induced e.m.f. is more sinusoidal due to short pitching.

3) As high frequency harmonics get eliminated, eddy current and hysteresis losses which depend on frequency also get minimised. This increases the efficiency.

### **3) Concentrated and Distributed winding:**

In three phase alternators, we have seen that there are three different sets of windings, each for a phase. So depending upon the total number of slots and number of poles, we have certain slots per phase available under each pole. This is denoted as 'm'.

$m = \text{Slots per pole per phase} = n/\text{number of phases}$

$= n/3$  (generally no. of phases is 3)

For example in 18 slots, 2 pole alternator

we have,  $n = 18/2 = 9$  and  $m = 9/3$

**So we have 3 slots per pole per phase available.** Now let 'x' number of conductors per phase are to be placed under one pole. And we have 3 slots per pole per phase available. But if all 'x' conductors per phase are placed in one slot keeping remaining 2 slots per pole per phase empty then the winding is called concentrated winding.

**Key Point: So in a concentrated winding, all conductors or coils belonging to a phase are placed in one slot under every pole.**

But in practice, an attempt is always made to use all the 'm' slots per pole per phase available for distribution of the winding. So if 'x' conductors per phase are distributed amongst the 3 slots per phase available under every pole, the winding is called distributed winding. So in distributed type of winding all the coils belonging to a phase are well distributed over the 'm' slots per phase, under every pole. Distributed winding makes the waveform of the induced e.m.f. more sinusoidal in nature. Also in concentrated winding due to a large number of conductors per slot, heat dissipation is poor.

**Key Point: So in practice, double layer, short pitched and distributed type of armature winding is preferred for the alternators.**

Full pitch coils are to be used so if phase 1 says R is started in slot 1, it is to be connected to a coil in slot 7. So that coil span will be 6 slots i.e. 'n' slots i.e. 1 pole pitch. As distributed winding is to be used, both the slots per pole per phase ( $m = 2$ ) available are to be used to place the coils. And all coils for one phase are to be connected in series.

So from slot No.7 we have to connect it to coil slot No.2 and slot No.2 second end to slot No.8 and so on. After finishing all slots per phase available under the first pair of pole, we will connect the coil to slot No.13 under next pole and winding will be repeated in a similar fashion. The starting end  $R_s$  and final end  $R_f$  winding for R-phase are taken out finally. Connections for R-phase only are shown in the below figure.

Now, we want to have a phase difference of  $120^\circ$  between 'R' and 'Y'. Each slot contributes  $30^\circ$  as  $\beta = 30^\circ$ . So start of 'Y' phase should be  $120^\circ$  apart from the start of 'R' i.e. 4 slots away from the start of R. So start of 'Y' will be in slot 5 and will get connected to slot No.11 to have full pitch coil. Similarly, the start of 'B' will be further  $120^\circ$  apart from 'Y' i.e. 4 slots apart start of 'Y' i.e. will be in slot No.9 and will continue similar to 'R'.

Finally, all six terminals of three sets will be brought out which are connected either in star or delta to get three ends R, Y and B outside to get three phase supply. The entire winding diagram with star connected windings is shown in the below figure.

### **Integral Slot Winding:**

The value of slots per pole per phase decides the class of the winding.

$$m = \text{slots / pole / phase}$$

**Key Point:** When the value of  $m$  is an integer, then the winding is called Integral slot winding.

Consider 2 pole, 12 slots alternator

$$\text{hence, } n = \text{slots / pole} = 12/2 = 6$$

$$\text{Pole pitch} = 180^\circ = 6 \text{ slots}$$

$$m = n/3 = 6/3 = 2$$

As  $m$  is an integer, the type of winding is integral slot winding. This winding can be **full pitch winding** or **short pitch winding**.

Let, the winding is full pitch winding. For integral slot winding, coils of one coil group lying under one pole pair are connected in series. Thus the end of the first coil is connected to start of the next coil lying to the right of the first coil. The alternate coil groups must be reversely

connected such that EMF is induced in them is additive in nature. Any slot contains the coil sides which belong to the same phase. Such a winding is shown in the below figure.

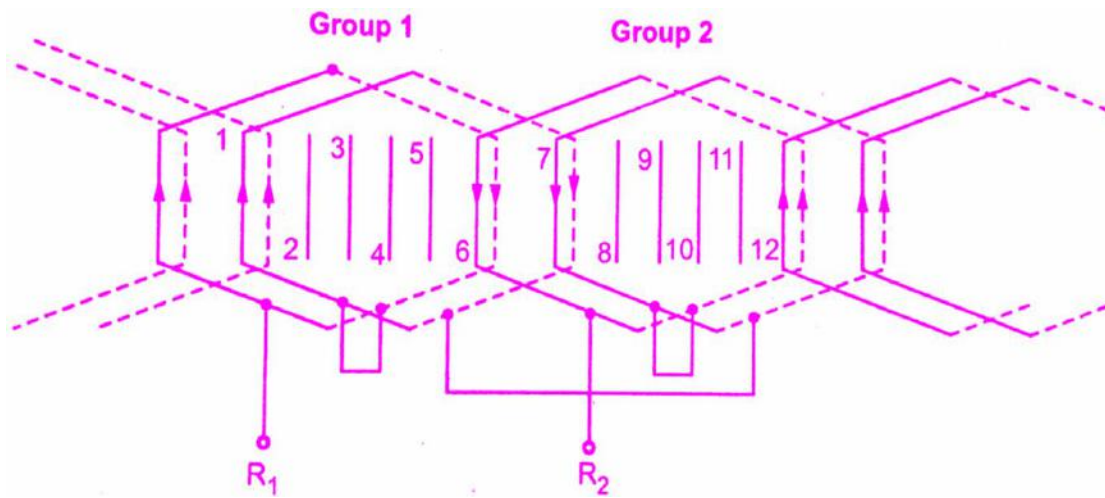

Fig: Double layer integral slot winding

If the short pitch coils are used for **integral slot winding** then in each group of the slots per pole phase, the coil sides of different phases exist.

### Fractional Slot Winding:

This is another **type of winding** which depends on the value of  $m$ .

**Key Point: The winding in which slots per pole per phase ( $m$ ) is a fractional number is called fractional slot winding.**

In such a winding, the number of slots ( $S$ ) must be divisible by 3. Thus slots per phase is an integer which is necessary to obtain symmetrical three phase winding. But slots per pole ( $n$ ) and slots per pole per phase ( $m$ ) both are fractional. As  $n$  is a fraction, the coils cannot be full pitch. Thus if there are 54 slots and 8 poles then the slots per pole  $n = 54/8 = 6.75$  hence coil span can be 7 or 6. Generally, short pitch coils are used. Such a fractional slot winding can be easily achieved with double layer winding.

In a balanced three phase winding, a basic unit under a pole pair (N and S) is repeated for remaining pole pairs where  $m$  is an integer. In fractional slot winding, the  $m$  is reduced to an irreducible fraction by taking out highest common factor in number of slots and poles.

Let

S = Number of slots

P = Number of poles

then for a 3 phase winding,

$$m = \frac{S}{3P} = \frac{k \left( \frac{S}{3k} \right)}{k \left( \frac{P}{k} \right)} = \frac{k S_k}{k P_k} = \frac{S_k}{P_k}$$

where

k = Highest common factor in S and P

$S_k/P_k$  = Characteristic ratio

The number k indicates the number of repeatable units and number of possible parallel paths. The characteristic ratio indicates that there are  $S_k$  coils per phase distributed among  $P_k$  poles. Thus the winding is to be considered only of  $P_k$  poles out of P poles and for other poles it is repeated.

Similarly, the winding arrangement is to be considered for  $S_k$  slots out of total S slots and for other slots it is repeated. In a double layer winding, only the arrangement of the top layer is to be considered. This gets repeated in the bottom layer in which the corresponding coil sides are located one coil span away.

### **Advantages of Fractional slot Windings:**

The various advantages of fractional slot winding are,

1. Though appearing to be complicated, easy to manufacture.
2. The number of armature slots (S) need not be an integral multiple of number of poles (P).
3. The number of slots can be selected for which notching gear is available, which is economical.
4. There is saving in machine tools.
5. High frequency harmonics are considerably reduced
6. The voltage waveform available is sinusoidal in nature.

### **Pitch Factor or Coil Span Factor**

Pitch Factor or Coil Span Factor is definite as the ratio of emf generated in short pitch coil to the emf generated in full pitch coil. It is denoted by  $K_p$  and its value is always less than unity. This factor basically represents the effect of short pitch winding on generated emf across the winding terminals of electrical machine.

As per the definition, the formula for pitch factor is given as below.

$$K_p = \frac{\text{emf generated in short pitch coil}}{\text{emf generated in full pitch coil}} \dots\dots\dots(1)$$

### Calculation of Pitch Factor or Coil Span Factor

To calculate the value of pitch factor, first of all we need to calculate the value of emf generated in short pitch coil and that in full pitch coil. Let us now calculate the emf generated in a short pitch coil. Figure below shows a short pitch coil.

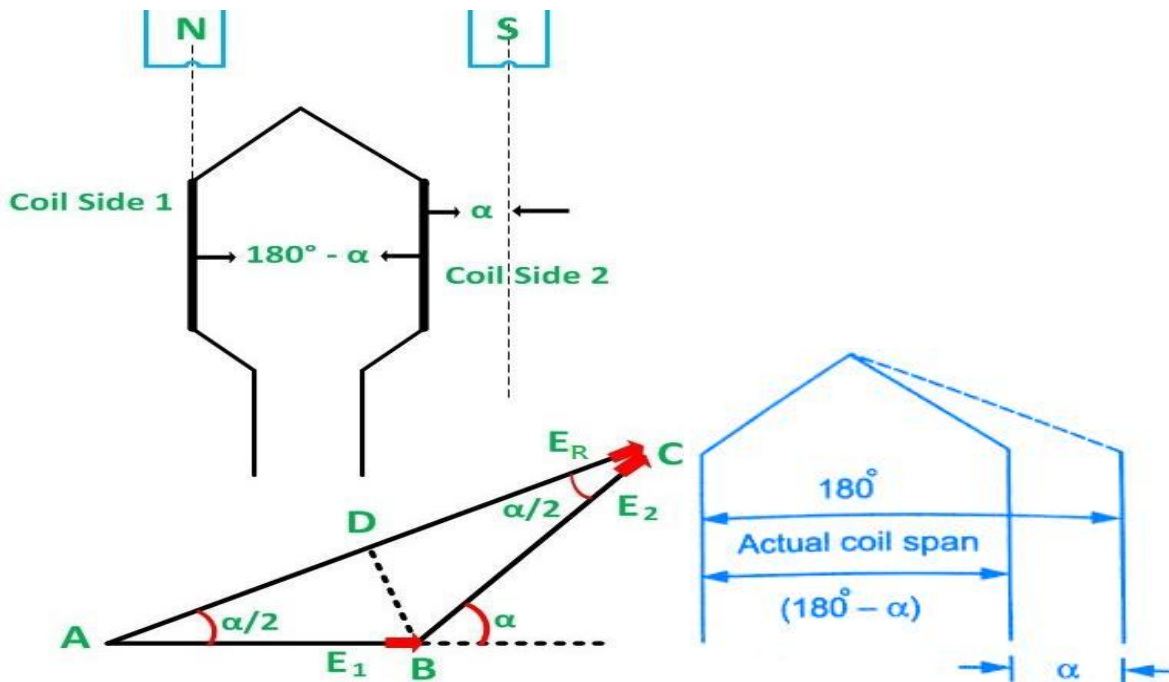

Let  $E_1$ ,  $E_2$  and  $E_R$  be the emf induced in coil side lying under North Pole, South Pole and resultant of emf generated in both the active lengths of coil. As the two coil sides are separated in space by an angle of  $(180-\alpha)$  i.e. the coil span is  $(180-\alpha)$ , therefore the emf induced in these coil sides will also be separated by this angle. This means, the angle between  $E_1$  and  $E_2$  phasor will be equal to  $\alpha$  as shown in figure below.

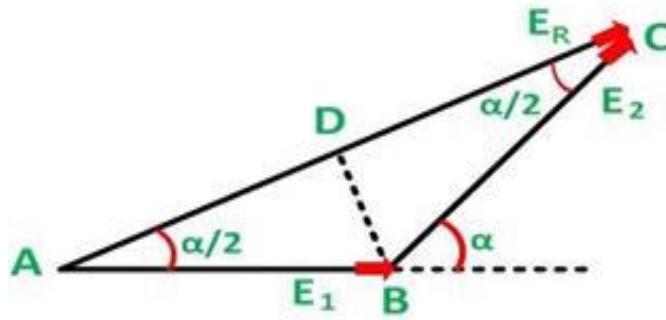

Since the magnitude of emf generated in both the coil sides are equal, therefore  $E_1 = E_2 = E$  (say). As the resultant emf  $E_R$  is the phasor sum of  $E_1$  and  $E_2$ , therefore

$$\begin{aligned}
 E_R &= \sqrt{(E_1)^2 + (E_2)^2 + 2E_1E_2\cos\epsilon} \\
 &= \sqrt{(E)^2 + (E)^2 + 2(E)^2\cos\epsilon} \\
 &= E\sqrt{2(1 + \cos\epsilon)} \\
 &= E\sqrt{2 \times 2\cos^2\left(\frac{\epsilon}{2}\right)} \\
 &= 2E\cos(\epsilon/2) \quad \dots\dots\dots(2)
 \end{aligned}$$

Above expression gives the emf induced in a single turn short pitch coil with chording angle  $\alpha$ . Since the chording angle for full pitch coil is 0 degree, therefore from the above expression (2), emf generated in a full pitch coil =  $2E$

Thus from (1),

$$\begin{aligned}
 \text{Pitch Factor, } K_p &= \frac{2E\cos(\alpha/2)}{2E} \\
 &= \cos(\alpha/2)
 \end{aligned}$$

Hence, pitch factor or coil span factor  $K_p = \cos(\alpha/2)$ .

For a **full pitch coil**, the value of pitch factor is **unity** whereas for its value is also **unity** for **concentrated coils**.

The pitch factor or coil span factor  $r^{\text{th}}$  harmonics is given as

$$K_p = \text{Cos} (r \alpha/2)$$

*The nth harmonic becomes zero, if,*

$$K_p = \text{Cos} (r \alpha/2)$$

$$\text{Cos} (r \alpha/2) = 0 \text{ or } r \alpha/2 = 90^\circ$$

*In 3 phase alternator, the 3<sup>rd</sup> harmonic is suppressed by star or delta connection as in the case of 3 phase transformer. Total attention is given for designing a 3 phase alternator winding design, for 5<sup>th</sup> and 7<sup>th</sup> harmonics.*

*For 5<sup>th</sup> harmonic*

$$\frac{5\alpha}{2} = 90^\circ \Rightarrow \alpha = \frac{180^\circ}{5} = 36^\circ$$

*For 7<sup>th</sup> harmonic*

$$\frac{7\alpha}{2} = 90^\circ \Rightarrow \alpha = \frac{180^\circ}{7} = 25.7^\circ$$

*Hence, by adopting a suitable chording angle of  $\alpha = 30^\circ$ , we make most optimized design*

## **DISTRIBUTION FACTOR OR BREADTH FACTOR**

The **Distribution Factor** or the **Breadth Factor** is defined as the ratio of the actual voltage obtained to the possible voltage if all the coils of a polar group were concentrated in a single slot. It is denoted by  $K_d$  and is given by the equation shown below.

If all the coil sides of any one phase under one pole are bunched in one slot, the winding obtained is known as concentrated winding and the total emf induced is equal to the arithmetic sum of the emfs induced in all the coils of one phase under one pole.

But in practical cases, for obtaining smooth sinusoidal voltage waveform, armature winding of alternator is not concentrated but distributed among the different slots to form polar groups under each pole. In distributed winding, coil sides per phase are displaced from each other by an angle equal to the angular displacement of the adjacent slots. Hence, the induced emf per coil side is not an angle equal to the angular displacement of the slots.

So, the resultant emf of the winding is the phasor sum of the induced emf per coil side. As it is



phasor sum, must be less than the arithmetic sum of these induced emfs. Resultant emf would be an arithmetic sum if the winding would have been a concentrated one.

As per definition, distribution factor is a measure of resultant emf of a distributed winding in compared to a concentrated winding.

We express it as the ratio of the phasor sum of the emfs induced in all the coils distributed in some slots under one pole to the arithmetic sum of the emfs induced. Distribution factor is,

$$k_d = \frac{\text{EMF induced in distributed winding}}{\text{EMF induced if the winding would have been concentrated}}$$

$$= \frac{\text{Phasor sum of component emfs}}{\text{Arithmetic sum of component emfs}}$$

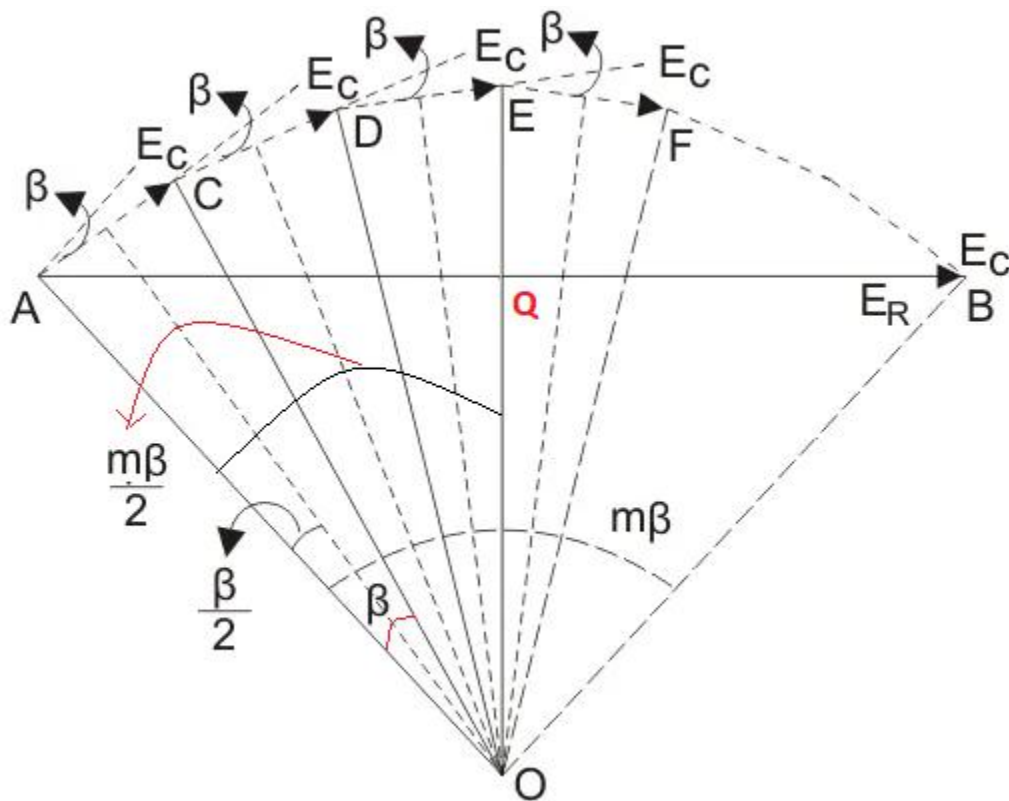

As pitch factor, distribution factor is also always less than unity.

Let the number of slots per pole is n.

The number of slots per pole per phase is m.

Induced emf per coil side is  $E_c$ .

Angular displacement between the slots,

$$\beta = \frac{180^\circ}{n}$$

Let us represent the emfs induced in different coils of one phase under one pole as AC, DC, DE, EF and so on. They are equal in magnitude, but they differ from each other by an angle  $\beta$ .

If we draw bisectors on AC, CD, DE, EF ———. They would meet at common point O.

Emf induced in each coil side,

From  $\Delta AOP$

$$\sin(\beta/2) = AP/OA$$

$$\sin(\beta/2) = (AC/2)/OA$$

$$AC/2 = OA \sin(\beta/2)$$

$$AC = 2 OA \sin(\beta/2)$$

$$E = AC = 2 \cdot OA \sin \frac{\beta}{2}$$

As the slot per pole per phase is  $m$ , the total arithmetic sum of all induced emfs per coil sides per pole per phase,

$$\text{Arithmetic sum} = m \times 2 \times OA \sin \frac{\beta}{2}$$

The resultant emf would be AB, as represented by the figure,

Hence, the resultant emf

$$\sin(m\beta/2) = AQ/OA$$

$$\sin(m\beta/2) = (AB/2)/OA$$

$$AB/2 = OA \sin(m\beta/2)$$

$$AB = 2 OA \sin(m\beta/2)$$

$$E_R = 2 OA \sin(m\beta/2)$$

*Therefore, Distribution Factor*

$$K_d = \frac{\text{Phasor sum of component emfs}}{\text{Arithmetic sum of component emfs}}$$
$$= \frac{2 \times OA \sin \frac{m\beta}{2}}{m \times 2 \times OA \sin \frac{\beta}{2}} = \frac{\sin \frac{m\beta}{2}}{m \sin \frac{\beta}{2}}$$

$m\beta$  is also known as the phase spread in electrical degree.

The distribution factor  $K_d$  given by equation is for the fundamental component of emf. If the flux distribution contains space harmonics the slot angular pitch  $\beta$  on the fundamental scale, would become  $r\beta$  for the  $r^{\text{th}}$  harmonic component and thus the distribution factor for the  $r^{\text{th}}$  harmonic would be.

$$K_{dr} = \frac{\sin \frac{rm\beta}{2}}{m \sin \frac{r\beta}{2}}$$

*Therefore, Winding Factor*

$$K_w = K_p \times K_d = \cos \frac{\alpha}{2} \times \frac{\sin \frac{m\beta}{2}}{m \sin \frac{\beta}{2}}$$

**AC MACHINES**  
**(20A02402T)**

**UNIT-II**  
**Induction Machines**

**LECTURE NOTES**

## UNIT-II

### THREE-PHASE INDUCTION MOTORS

Polyphase Induction Motors-Constructional Details of Cage and Wound Rotor Machines-Production of Rotating Magnetic Field - Principle of Operation – Slip - Rotor Emf and Rotor Frequency - Rotor Reactance, Rotor Current and Power factor at Standstill and under running conditions - Rotor Power Input, Rotor Copper Loss and Mechanical Power Developed and Their Inter Relationship.

#### **Three Phase Induction Motor Definition & Working Principle**

An electrical motor is such an electromechanical device which converts electrical energy into a mechanical energy. In case of three phase AC operation, most widely used motor is **three phase induction motor** as this type of motor does not require any starting device or we can say they are self-starting induction motors.

The stator of the motor consists of overlapping winding offset by an electrical angle of  $120^\circ$ . When we connect the primary winding, or the stator to a 3 phase AC source, it establishes rotating magnetic field which rotates at the synchronous speed.

According to Faraday's law an emf induced in any circuit is due to the rate of change of magnetic flux linkage through the circuit. As the rotor winding in an induction motor are either closed through an external resistance or directly shorted by end ring, and cut the stator rotating magnetic field, an emf is induced in the rotor copper bar and due to this emf a current flows through the rotor conductor.

Here the relative speed between the rotating flux and static rotor conductor is the cause of current generation; hence as per Lenz's law, the rotor will rotate in the same direction to reduce the cause, i.e., the relative velocity.

Thus from the **working principle of three phase induction motor**, it may be observed that the rotor speed should not reach the synchronous speed produced by the stator. If the speeds become equal, there would be no such relative speed, so no emf induced in the rotor, and no current would be flowing, and therefore no torque would be generated. Consequently, the rotor cannot reach the synchronous speed. The difference between the stator (synchronous speed) and rotor speeds is called the slip. The rotation of the magnetic field in an induction motor has the advantage that no electrical connections need to be made to the rotor.

Thus the **three phase induction motor** is:

- Self-starting.
- Less armature reaction and brush sparking because of the absence of commutators and brushes that may cause sparks.
- Robust in construction.
- Economical.
- Easier to maintain.

**Rotating Magnetic Field**

A three phase induction motor consists of three phase winding as its stationary part called stator. The three phase stator winding is connected in star or delta. The three phase windings are displaced from each other by 120°. The windings are supplied by a balanced three phase a.c. supply. This is shown in the Fig. 1. The three phase windings are denoted as R-R', Y-Y' and B-B'.

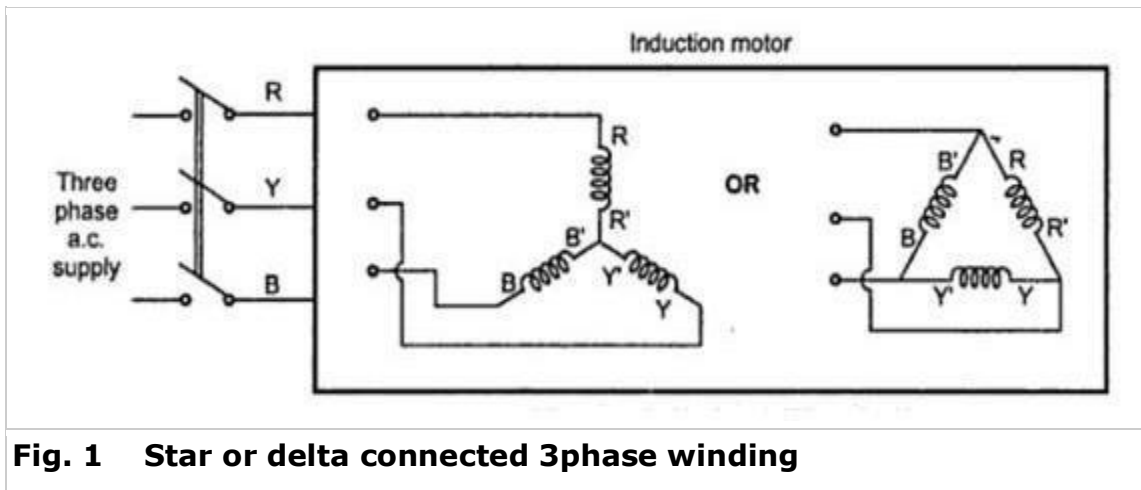

**Fig. 1 Star or delta connected 3phase winding**

The three phase currents flow simultaneously through the windings and are displaced from each other by 120° electrical. Each alternating phase current produces its own flux which is sinusoidal. So all three fluxes are sinusoidal and are separated from each other by 120°. If the phase sequence of the windings is R-Y-B, then mathematical equations for the instantaneous values of the three fluxes  $\Phi_R$ ,  $\Phi_Y$  and  $\Phi_B$  can be written as,

$$\Phi_R = \Phi_m \sin(\Phi t) = \Phi_m \sin \theta \quad \dots\dots\dots(1)$$

$$\Phi_Y = \sin (\Phi t - 120^\circ) = \Phi_m \sin (\theta - 120^\circ) \quad \dots\dots\dots(2)$$

$$\Phi_B = \Phi_m \sin (\Phi t - 240^\circ) = \Phi_m \sin (\theta - 240^\circ) \quad \dots\dots\dots(3)$$

As windings are identical and supply is balanced, the magnitude of each flux is  $\Phi_m$ . Due to phase sequence R-Y-B, flux lags behind  $\Phi_R$  by  $120^\circ$  and  $\Phi_B$  lags  $\Phi_Y$  by  $120^\circ$ . So  $\Phi_B$  ultimately lags  $\Phi_R$  by  $240^\circ$ . The flux  $\Phi_R$  is taken as reference while writing the equations.

The Fig. 2(a) shows the waveforms of three fluxes in space. The Fig.2 (b) shows the Phasor diagram which clearly shows the assumed positive directions of each flux. Assumed positive direction means whenever the flux is positive it must be represented along the direction shown and whenever the flux is negative it must be represented along the opposite direction to the assumed positive direction.

Let  $\Phi_R$ ,  $\Phi_Y$  and  $\Phi_B$  be the instantaneous values of the three fluxes. The resultant flux  $\Phi_T$  is the Phasor addition of  $\Phi_R$ ,  $\Phi_Y$  and  $\Phi_B$ .

Let us find  $\Phi_T$  at the instants 1, 2, 3 and 4 as shown in the Fig. 2(a) which represents the values of  $\Phi$  as  $0^\circ$ ,  $60^\circ$ ,  $120^\circ$  and  $180^\circ$  respectively. The Phasor addition can be performed by obtaining the values of  $\Phi_R$ ,  $\Phi_Y$  and  $\Phi_B$  by substituting values of  $\Phi$  in the equation (1), (2) and (3).

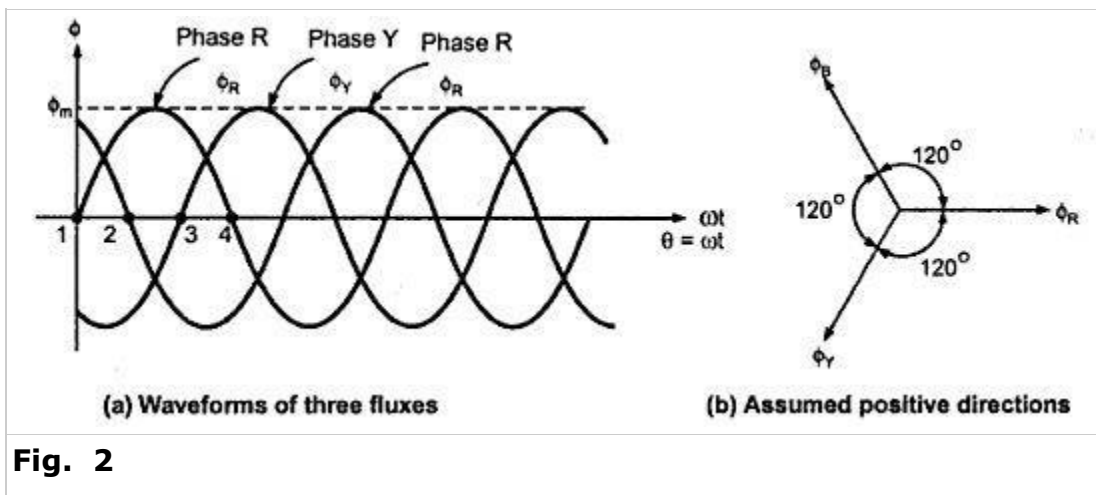

**Fig. 2**

**Case 1 :**  $\theta = 0^\circ$

Substituting in the equations (1), (2) and (3) we get,

$$\Phi_R = \Phi_m \sin 0^\circ = 0$$

$$\Phi_Y = \Phi_m \sin(-120^\circ) = -0.866 \Phi_m$$

$$\Phi_B = \Phi_m \sin(-240^\circ) = + 0.866 \Phi_m$$

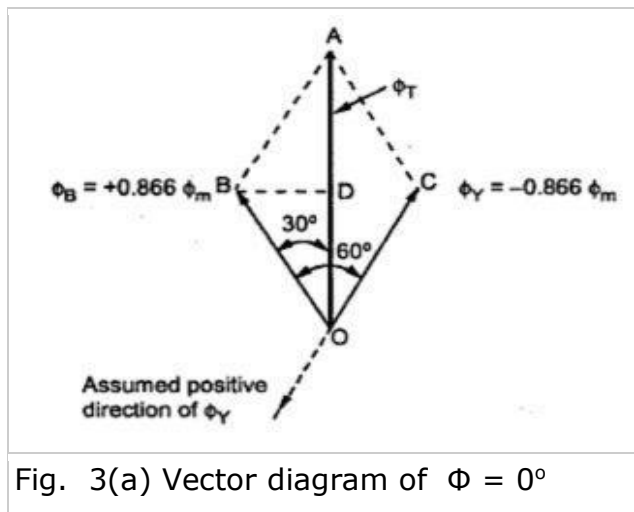

Fig. 3(a) Vector diagram of  $\Phi = 0^\circ$

The phasor addition is shown in the Fig. 3(a). The positive values are shown in assumed positive directions while negative values are shown in opposite direction to the assumed positive directions of the respective fluxes. Refer to assumed positive directions shown in the Fig 3(b).

BD is drawn perpendicular from B on  $\Phi_T$ . It bisects  $\Phi_T$ .

$$\therefore OD = DA = \Phi_T/2$$

In triangle  $\angle OBD = 30^\circ$

$$\therefore \cos 30^\circ = OD/OB = (\Phi_T/2)/(0.866 \Phi_m)$$

$$\begin{aligned} \therefore \Phi_T &= 2 \times 0.866 \Phi_m \times \cos 30^\circ \\ &= 1.5 \Phi_m \end{aligned}$$

So magnitude of  $\Phi_T$  is  $1.5 \Phi_m$  and its position is vertically upwards at  $\Phi = 0^\circ$ .

### Case 2 $\theta = 60^\circ$

Equation (1),(2) and (3) give us,

$$\Phi_R = \Phi_m \sin 60^\circ = +0.866 \Phi_m$$

$$\Phi_Y = \Phi_m \sin (-60^\circ) = -0.866 \Phi_m$$

$$\Phi_B = \Phi_m \sin (-180^\circ) = 0$$

So  $\Phi_R$  is positive and  $\Phi_Y$  is negative and hence drawing in appropriate directions we get phasor diagram as shown in the Fig. 3(b).



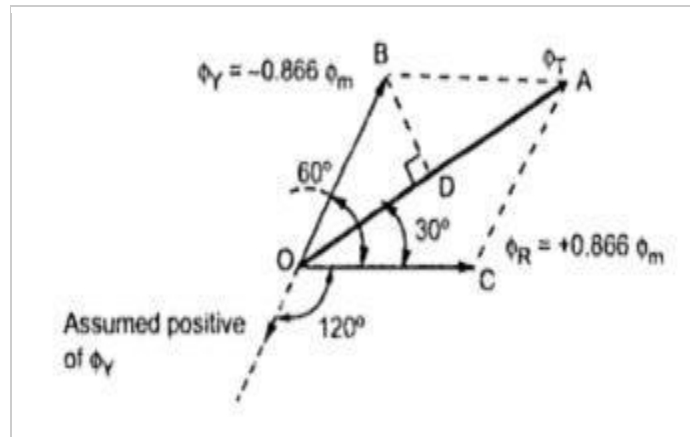

Fig 3(b) Vector diagram of  $\Phi = 60^\circ$

Doing the same construction, drawing perpendicular from B on at D we get the same result as,

$$\Phi_T = 1.5 \Phi_m$$

But it can be seen that though its magnitude is  $1.5 \Phi_m$  it has rotated through  $60^\circ$  in space, in clockwise direction, from its previous position.

**Case 3**  $\theta = 120^\circ$

Equations (1),(2) and (3) give us,

$$\Phi_R = \Phi_m \sin 120^\circ = +0.866 \Phi_m$$

$$\Phi_Y = \Phi_m \sin 0^\circ = 0$$

$$\Phi_B = \Phi_m \sin (-120^\circ) = -0.866 \Phi_m$$

So  $\Phi_R$  is positive and  $\Phi_B$  is negative. Showing  $\Phi_R$  and  $\Phi_B$  in the appropriate directions, we get the Phasor diagram as shown in the Fig.3 (c).

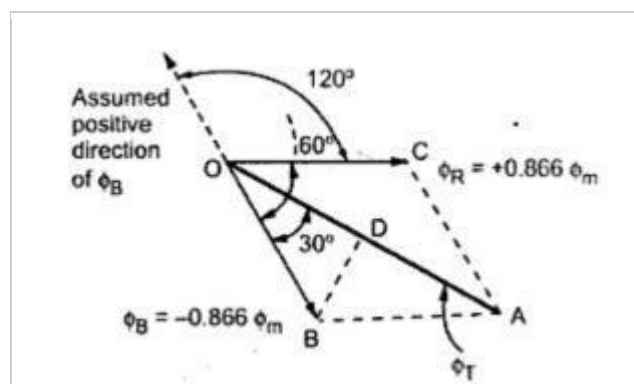

Fig. 3(c) Vector diagram of  $\Phi = 120^\circ$

After doing the construction same as before i.e. drawing perpendicular from B on  $\Phi_T$ , it can be provided again that,  $\Phi_T = 1.5 \Phi_m$

But the position of  $\Phi_T$  is such that it has rotated further through  $60^\circ$  from its previous position, in clockwise direction. And from its position at  $\Phi = 0^\circ$ , it has rotated through  $120^\circ$  in space, in clockwise direction.

**Case 4 :**  $\theta = 180^\circ$

From equations (1),(2) and (3),

$$\Phi_R = \Phi_m \sin (180^\circ) = 0$$

$$\Phi_Y = \Phi_m \sin (60^\circ) = +0.866 \Phi_m$$

$$\Phi_B = \Phi_m \sin (-60^\circ) = -0.866 \Phi_m$$

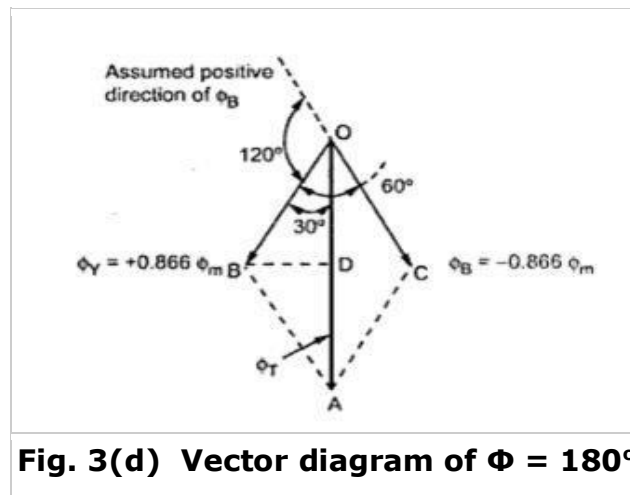

So  $\Phi_R = 0$  ,  $\Phi_Y$  is positive and  $\Phi_B$  is negative. Drawing  $\Phi_Y$  and  $\Phi_B$  in the appropriate directions, we get the phasor diagram as shown in the Fig. 3(d).

From phasor diagram, it can be easily proved that,

$$\Phi_T = 1.5 \Phi_m$$

Thus the magnitude of  $\Phi_T$  once again remains same. But it can be seen that it has further rotated through  $60^\circ$  from its previous position in clockwise direction.

So for an electrical half cycle of  $180^\circ$ , the resultant  $\Phi_T$  has also rotated through. This is applicable for the windings from the above discussion we have following conclusions:

- a) The resultant of the three alternating fluxes, separated from each other by, has constant amplitude of  $1.5 \Phi_m$  where  $\Phi_m$  is maximum amplitude of an individual flux due to any phase.
- b) The resultant always keeps on rotating with a certain speed in space.

### **Speed of R.M.F.**

There exists a fixed relation between frequency  $f$  of a.c. supply to the windings, the number of poles  $P$  for which winding is wound and speed  $N$  r.p.m. of rotating magnetic field. For a standard frequency whatever speed of R.M.F. results is called synchronous speed, in case of induction motors. It is denoted as

$$N_s = \frac{120f}{P} = \text{Speed of R.M.F.}$$

Where

$f$  = Supply frequency in Hz

$P$  = Number of poles for which winding is wound

### **Constructional Details**

The three basic parts of an induction motor are the stator, rotor, and enclosure.

The stator and the rotor are electrical circuits that perform as electromagnets.

### **STATOR**

- ☐ The stator is the stationary electrical part of the motor.
- ☐ The stator core of a induction motor is made up of several hundred thin laminations.
- ☐ Stator laminations are stacked together forming a hollow cylinder. Coils of insulated wire are inserted into slots of the stator core.
- ☐ Each grouping of coils, together with the steel core it surrounds, form an electromagnet. The stator windings are connected directly to the power source.

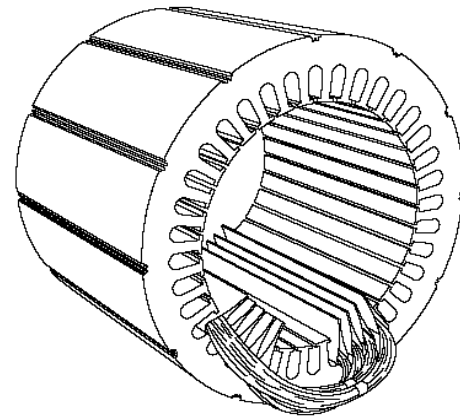
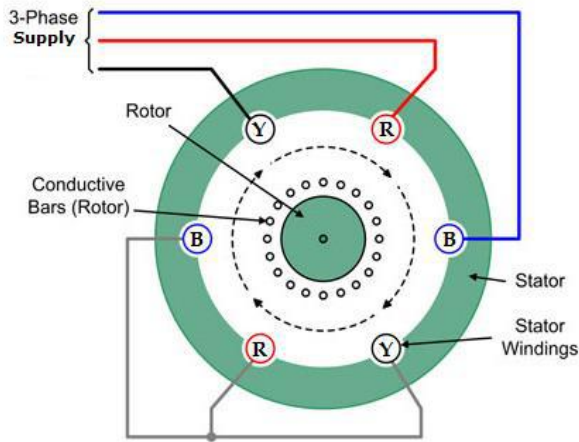

## **ROTOR**

It is the part of the motor which will be in a rotation to give mechanical output for a given amount of electrical energy. The rated output of the motor is mentioned on the nameplate in horsepower. It consists of a shaft, short-circuited copper/aluminum bars, and a core.

The rotor core is laminated to avoid power loss from eddy currents and hysteresis. Conductors are skewed to prevent cogging during starting operation and gives better transformation ratio between stator and rotor.

The rotor is the rotating part of the electromagnetic circuit.

It can be found in two types:

- Squirrel cage
- Wound rotor(Slip ring)

However, the most common type of rotor is the "squirrel cage" rotor.

## **SQUIRREL CAGE ROTOR**

- Rotor winding is composed of copper bars embedded in the rotor slots and shorted at both end by end rings
- Simple, low cost, robust, low maintenance

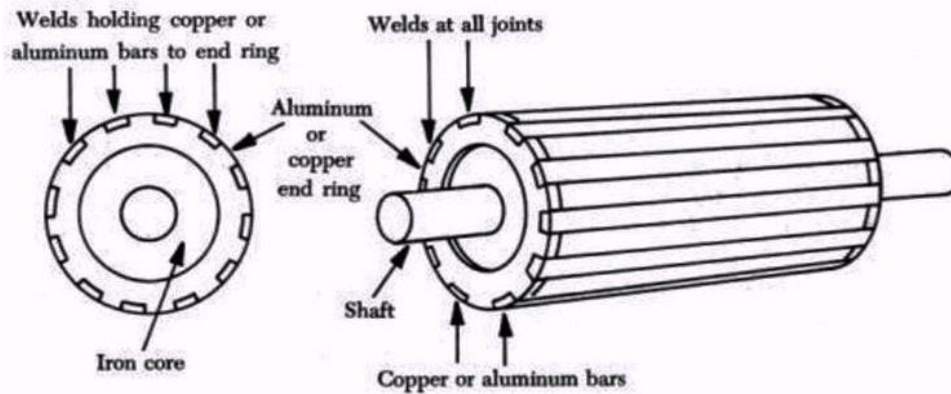
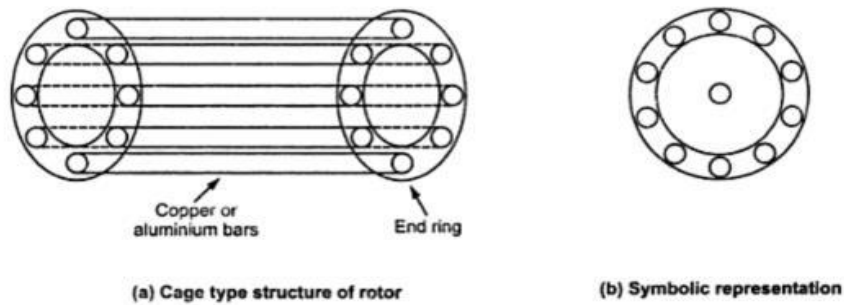

### **Application of Squirrel cage induction motors**

These are commonly used in many industrial applications. They are particularly suited for applications where the motor must maintain a constant speed, be self-starting, or there is a desire for low maintenance.

- These motors are commonly used in:
- Centrifugal pumps
- Industrial drives (e.g. to run conveyor belts)
- Large blowers and fans
- Machine tools
- Lathes and other turning equipment

### **Advantages of Squirrel Cage Induction Rotor**

1. Its construction is very simple and rugged.
2. As there are no brushes and slip ring, these motors requires less maintenance.

## WOUND ROTOR (SLIP RING)

- Rotor winding is wound by wires.
- The winding terminals can be connected to external circuits through slip rings and brushes.
- Easy to control speed, more expensive.

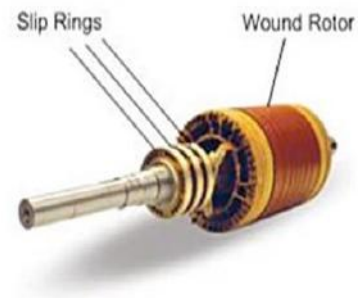
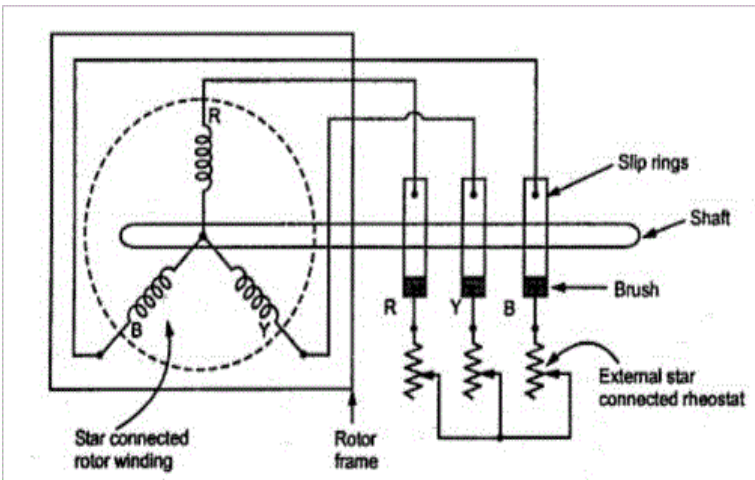

### **Application of Slip Ring Induction Motor**

Slip ring induction motor are used where high starting torque is required

- Hoists
- Cranes
- elevator etc.

### **Advantages of Slip Ring Induction Motor**

1. It has high starting torque and low starting current.
2. Possibility of adding additional resistance to control speed.

### **Difference between Slip Ring and Squirrel Cage Induction Motor**

Slip ring or phase wound Induction motor	Squirrel cage induction motor
Construction is complicated due to presence of slip ring and brushes	Construction is very simple
The rotor winding is similar to the stator winding	The rotor consists of rotor bars which are permanently shorted with the help of end rings

We can easily add rotor resistance by using slip ring and brushes	Since the rotor bars are permanently shorted, its not possible to add external resistance
Due to presence of external resistance high starting torque can be obtained	Starting torque is low and cannot be improved
Slip ring and brushes are present	Slip ring and brushes are absent
Frequent maintenance is required due to presence of brushes	Less maintenance is required
The construction is complicated and the presence of brushes and slip ring makes the motor more costly	The construction is simple and robust and it is cheap as compared to slip ring induction motor
This motor is rarely used only 10% industry uses slip ring induction motor	Due to its simple construction and low cost. The squirrel cage induction motor is widely used
Rotor copper losses are high and hence less efficiency	Less rotor copper losses and hence high efficiency
Speed control by rotor resistance method is possible	Speed control by rotor resistance method is not possible
Slip ring induction motor are used where high starting torque is required i.e in hoists, cranes, elevator etc	Squirrel cage induction motor is used in lathes, drilling machine, fan, blower printing machines etc

## **Slip**

**Slip in Induction Motor is the relative speed between the rotating magnetic flux and rotor expressed in terms of per unit synchronous speed.** It is a dimensionless quantity. The value of slip in induction motor is can never be zero

If  $N_s$  and  $N_r$  being the synchronous speed of rotating magnetic flux and rotor speed respectively, then the relative speed between them is equal to  $(N_s - N_r)$ . Therefore, slip is defined as

$$\text{Slip (s)} = (N_s - N_r) / N_s$$

As we know that, the speed of rotor cannot be equal to synchronous speed i.e.  $N_r < N_s$ , the value of slip  $s$  is always less than one. For induction motor,  $0 < s < 1$ .

Value of Slip ( $s$ )	Significance
$s = 0$ (Zero Slip)	<p>Zero slip means that rotor speed is equal to synchronously rotating magnetic flux. Under this condition, there will not be any relative motion between the rotor coils and rotating magnetic flux. Therefore, there will not be any flux cutting action of rotor coils. Hence, no emf will be generated in rotor coils to produce rotor current. This means no electromagnetic torque will be produced. Induction motor will not work. Therefore, it very important for induction motor to have a positive value of slip. This is the reason; slip is never zero in an induction motor.</p>
$s = 1$ (Slip equal to 1)	<p>Slip = 1, means that rotor is stationary.</p>
$s = \text{Negative}$ (Negative Slip)	<p>Negative value of slip in induction motor can be achieved when the rotor speed is more than the synchronously rotating magnetic flux. This is only possible, when the rotor is rotated in the direction of rotating magnetic flux by some prime mover. Under this condition, the machine operates as an Induction Generator. Read Torque Slip Characteristics for detail.</p>



$s > 1$  (Slip greater than 1)

Slip more than 1 implies that, rotor is rotating in a direction opposite to the direction of rotation of magnetic flux. This means if magnetic flux is rotating in clockwise direction, then rotor is rotating in anticlockwise direction or vice versa. Therefore, the relative speed between them will be  $(N_s + N_r)$ . In Plugging or Braking of Induction motor, slip more than 1 is achieved to quickly bring the rotor at rest.

### **Losses and Efficiency of Induction Motor**

There are two types of losses occur in three phase induction motor. These losses are,

1. Constant or fixed losses,
2. Variable losses.

#### **1. Constant or Fixed Losses**

Constant losses are those losses which are considered to remain constant over normal working range of induction motor. The fixed losses can be easily obtained by performing no-load test on the three phase induction motor. These losses are further classified as-

- a) Iron or core losses,
- b) Mechanical and Brush friction losses.

#### **a)Iron or Core Losses**

Iron or core losses are further divided into hysteresis and eddy current losses. Eddy current losses are minimized by using lamination on core. Since by laminating the core, area decreases and hence resistance increases, which results in decrease in eddy currents. Hysteresis losses are minimized by using high grade silicon steel. The core losses depend upon frequency of the supply voltage. The frequency of stator is always supply frequency,  $f$  and the frequency of rotor is slip times the supply frequency,  $(sf)$  which is always less than the stator frequency. For stator

frequency of 50 Hz, rotor frequency is about 1.5 Hz because under normal running condition slip is of the order of 3 %. Hence the rotor core loss is very small as compared to stator core loss and is usually neglected in running conditions.

## **b) Mechanical and Brush Friction Losses**

Mechanical losses occur at the bearing and brush friction loss occurs in wound rotor induction motor. These losses are zero at start and with increase in speed these losses increases. In three phase induction motor the speed usually remains constant. Hence these losses almost remains constant.

## **2.Variables Losses**

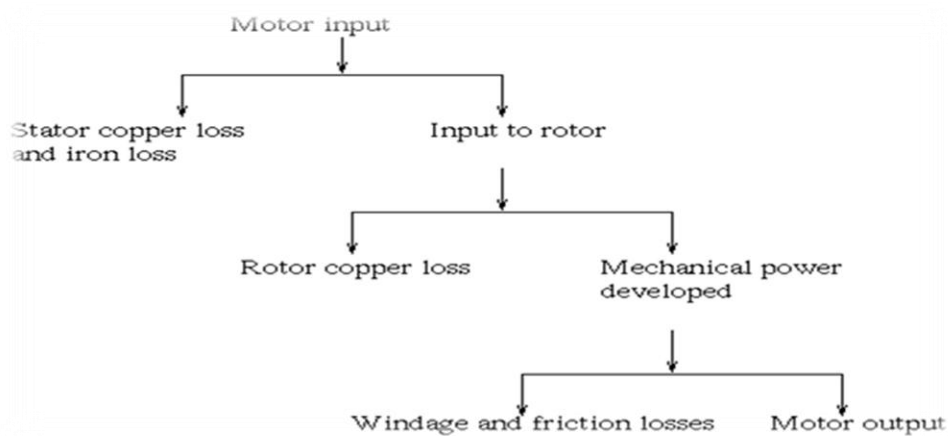

These losses are also called copper losses. These losses occur due to current flowing in stator and rotor windings. As the load changes, the current flowing in rotor and stator winding also changes and hence these losses also changes. Therefore these losses are called variable losses. The copper losses are obtained by performing blocked rotor test on three phase induction motor.

## Power Flow Diagram of Induction Motor

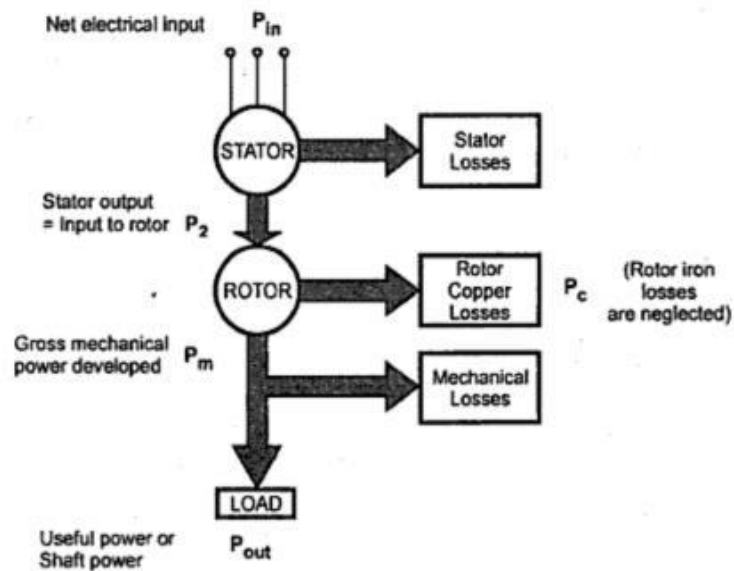

The main function of induction motor is to convert an electrical power into mechanical power. During this conversion of electrical energy into mechanical energy the power flows through different stages.

This power flowing through different stages is shown by power flow diagram. As we all know the input to the three phase induction motor is three phase supply. So, the three phase supply is given to the stator of three phase induction motor.

Let,  $P_{in}$  = electrical power supplied to the stator of three phase induction motor,

$V_L$  = line voltage supplied to the stator of three phase induction motor,

$I_L$  = line current,

$\cos\phi$  = power factor of the three phase induction motor.

Electrical power input to the stator,

$$P_{in} = \sqrt{3}V_L I_L \cos\phi$$

A part of this power input is used to supply stator losses which are stator iron loss and stator copper loss.

The remaining power i.e (input electrical power – stator losses) are supplied to rotor as rotor input.

So, rotor input  $P_2 = P_{in} - \text{stator losses}$  (stator copper loss and stator iron loss).

Now, the rotor has to convert this rotor input into mechanical energy but this complete input cannot be converted into mechanical output as it has to supply rotor

losses. As explained earlier the rotor losses are of two types rotor iron loss and rotor copper loss. Since the iron loss depends upon the rotor frequency, which is very small when the rotor rotates, so it is usually neglected. So, the rotor has only rotor copper loss. Therefore the rotor input has to supply these rotor copper losses. After supplying the rotor copper losses, the remaining part of Rotor input,  $P_2$  is converted into mechanical power,  $P_m$ .

**Let  $P_c$  be the rotor copper loss,**

**$I_2$  be the rotor current under running condition,**

**$R_2$  is the rotor resistance,**

**$P_m$  is the gross mechanical power developed.**

$$P_c = 3I_2^2R_2$$

$$P_m = P_2 - P_c$$

Now this mechanical power developed is given to the load by the shaft but there occur some mechanical losses like friction and windage losses. So, the gross mechanical power developed has to be supplied to these losses. Therefore the net output power developed at the shaft, which is finally given to the load is  $P_{out}$ .  
 $P_{out} = P_m - \text{Mechanical losses (friction and windage losses)}$ .

$P_{out}$  is called the shaft power or useful power.

### **Efficiency of Three Phase Induction Motor**

Efficiency is defined as the ratio of the output to that of input,

$$\text{Efficiency, } \eta = \frac{\text{output}}{\text{input}}$$

Rotor efficiency of the three phase induction motor ,

$$= \frac{\text{rotor output}}{\text{rotor input}}$$

= Gross mechanical power developed / rotor input

$$= \frac{P_m}{P_2}$$

Three phase induction motor efficiency,

$$= \frac{\text{power developed at shaft}}{\text{electrical input to the motor}}$$

Three phase induction motor efficiency

$$\eta = \frac{P_{out}}{P_{in}}$$

**Relation between P<sub>2</sub>, P<sub>c</sub> and P<sub>m</sub>**

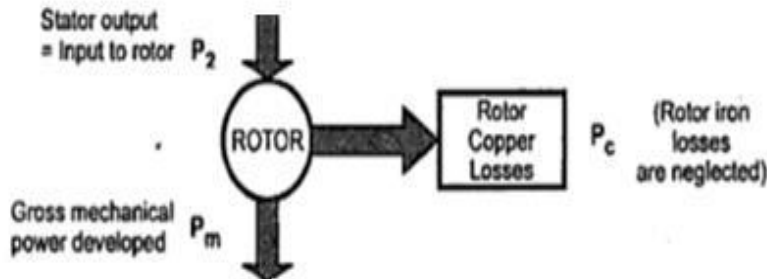

The rotor input P<sub>2</sub>, rotor copper loss P<sub>c</sub> and gross mechanical power developed P<sub>m</sub> are related through the slip s. Let us derive this relationship.

Let T = Gross torque developed by motor in N-m.

We know that the torque and power are related by the relation,

$$P = T \times \omega$$

where P = Power

$\omega$  = angular speed

$$= (2\pi N)/60, N = \text{speed in r.p.m.}$$

Now input to the rotor P<sub>2</sub> is from stator side through rotating magnetic field which is rotating at synchronous speed N<sub>s</sub>.

So torque developed by the rotor can be expressed in terms of power input and angular speed at which power is inputted i.e.  $\omega_s$  as,

$$P_2 = T \times \omega_s \quad \text{where } \omega_s = (2\pi N_s)/60 \text{ rad/sec}$$

$$P_2 = T \times (2\pi N_s)/60 \quad \text{where } N_s \text{ is in r.p.m.} \quad \dots\dots\dots(1)$$

The rotor tries to deliver this torque to the load. So rotor output is gross mechanical power developed P<sub>m</sub> and torque T. But rotor gives output at speed N and not N<sub>s</sub>. So from output side P<sub>m</sub> and T can be related through angular speed  $\omega$  and not  $\omega_s$ .

$$P_m = T \times \omega \quad \text{where } \omega = (2\pi N)/60$$

$$P_m = T \times (2\pi N)/60 \quad \dots\dots\dots(2)$$

The difference between P<sub>2</sub> and P<sub>m</sub> is rotor copper loss P<sub>c</sub>.

$$P_c = P_2 - P_m = T \times (2\pi N_s/60) - T \times (2\pi N/60)$$

$$P_c = T \times (2\pi/60)(N_s - N) = \text{rotor copper loss} \quad \dots\dots\dots(3)$$

Dividing (3) by (1),

$$\frac{P_c}{P_2} = \frac{T \times \frac{2\pi}{60} (N_s - N)}{T \times \frac{2\pi}{60} \times N_s} = \frac{N_s - N}{N_s}$$

$$P_c/P_2 = s$$

$$P_c = s \times P_2$$

Thus total rotor copper loss is slip times the rotor input.

Now  $P_2 - P_c = P_m$

$$P_2 - sP_2 = P_m$$

$$(1 - s)P_2 = P_m$$

Thus gross mechanical power developed is (1 - s) times the rotor input

The relationship can be expressed in the ratio form as,

<b><math>P_2 : P_c : P_m</math></b>	<b>is</b>	<b><math>1 : s : 1 - s</math></b>
-------------------------------------	-----------	-----------------------------------

The ratio of any two quantities on left hand side is same as the ratio of corresponding two sides on the right hand side.

For example,	$\frac{P_c}{P_m} = \frac{s}{1-s}, \quad \frac{P_2}{P_c} = \frac{1}{s} \quad \text{and so on.}$
--------------	--

This relationship is very important and very frequently required to solve the problems on the power flow diagram.

A three-phase, 20 hp, 208 V, 60 Hz, six pole, wye connected induction motor delivers 15 kW at a slip of 5%.

Calculate:

- Synchronous speed
- Rotor speed
- Frequency of rotor current

**Solution**

- Synchronous speed:  $n_s = 120 f / p = (120 \cdot 60) / 6 = 1200 \text{ rpm}$
- Rotor speed:  $n_r = (1-s) n_s = (1 - 0.05) (1200) = 1140 \text{ rpm}$
- Frequency of rotor current:  $f_r = s f = (0.05) (60) = 3 \text{ Hz}$

**Example**

A three-phase, 460 V, 100 hp, 60 Hz four-pole induction machine delivers rated output power at a slip of 0.05 (this can be stated as a slip of 5%). Determine the

- synchronous speed.
- motor speed.
- frequency of the rotor circuit.
- slip speed.

(a)  $n_s = 120 \frac{f}{P} = 120 \frac{60}{4} = 1800 \text{ rpm}$

(b)  $n = n_s (1 - s) = 1800 (1 - 0.05) = 1710 \text{ rpm}$

(c)  $f_r = s f = (0.05)(60) = 3 \text{ Hz}$

(d)  $n_{slip} = s n_s = (0.05)(1800) = 90 \text{ rpm}$

►► **Example 5.21 :** A three phase, 50 Hz, 500 V induction motor develops 20 B.H.P. at a slip of 5 %. The mechanical losses are 1 H.P. The stator losses are 1000 W. Calculate its efficiency.

**Solution :** The given values are,

$$s = 5\% \text{ i.e. } 0.05, P_{\text{out}} = 20 \text{ B.H.P.}, \text{ Mechanical loss} = 1 \text{ H.P.}$$

$$f = 50 \text{ Hz}, E_{\text{line}} = 500 \text{ V}, \text{ stator loss} = 1000 \text{ W}$$

Now  $1 \text{ B.H.P.} = 1 \text{ H.P.} = 735.5 \text{ W}$

$$\therefore P_{\text{out}} = 20 \times 735.5 = 14710 \text{ W and mechanical loss} = 735.5 \text{ W}$$

Now  $P_{\text{out}} = P_m - \text{mechanical loss}$

$$\therefore P_m = P_{\text{out}} + \text{mechanical loss} = 14710 + 735.5 = 15445.5 \text{ W}$$

Now  $P_2 : P_c : P_m$  is  $1 : s : 1 - s$

$$\therefore \frac{P_2}{P_m} = \frac{1}{1 - s}$$

$$\therefore P_2 = \frac{P_m}{1 - s} = \frac{15445.5}{(1 - 0.05)}$$

$$= 16258.421 \text{ W} = \text{rotor input}$$

Net input,  $P_{\text{in}} = P_2 + \text{stator loss} = 16258.421 + 1000$

$$= 17258.421 \text{ W}$$

$$\therefore \% \eta = \frac{P_{\text{out}}}{P_{\text{in}}} \times 100 = \frac{14710}{17258.421} \times 100 = 85.23 \%$$

►► **Example 5.22 :** A 4 pole, 30 H.P., three phase, 400 V, 50 Hz induction motor operates at an efficiency of 0.8 with a p.f. of 0.75 lagging. Calculate the current drawn by the motor from the mains.

**Solution :** The given values are,

$$P = 4, f = 50 \text{ Hz}, P_{\text{out}} = 30 \text{ H.P.}, V_L = \text{Line voltage} = 400 \text{ V}$$

$$\cos \phi = 0.75, \quad \eta = 0.8$$

$$P_{\text{out}} = 30 \times 735.5 = 22065 \text{ W}$$

$$\eta = \frac{P_{\text{out}}}{P_{\text{in}}} = \frac{22065}{0.8} = 27581.25 \text{ W}$$

Now  $P_{\text{in}} = \sqrt{3} V_L I_L \cos \phi$

$$\therefore 27581.25 = \sqrt{3} \times 400 \times I_L \times 0.75$$

$$\therefore I_L = 53.08 \text{ A}$$



## Torque Equation of Three Phase Induction Motor

The torque produced by [three phase induction motor](#) depends upon the following three factors:

1. The magnitude of rotor current
2. The [flux](#) which interact with the rotor of three phase induction motor and is responsible for producing emf in the rotor part of [induction motor](#)
3. The [power factor](#) of rotor of the three phase induction motor.

Combining all these factors, we get the equation of torque as-

$$T \propto \phi I_{2r} \cos\theta_{2r}$$

$$T = k \phi I_{2r} \cos\theta_{2r}$$

where,

$\phi$  = flux per stator pole,

$I_2$  = rotor current at standstill,

$\theta_2$  = angle between rotor emf and rotor current,

k = a constant.

The flux  $\phi$  produced by the stator is proportional to stator emf  $E_1$ .

$$\text{i.e } \phi \propto E_1$$

We know that transformation ratio K is defined as the ratio of secondary [voltage](#) (rotor voltage) to that of primary voltage (stator voltage).

$$K = \frac{E_2}{E_1}$$

$$\text{or, } K = \frac{E_2}{\phi}$$

$$\text{or, } E_2 = \phi$$

Rotor [current](#)  $I_2$  is defined as the ratio of rotor induced emf under running condition,  $sE_2$  to total impedance,  $Z_2$  of rotor side,

$$I_{2r} = \frac{sE_2}{Z_{2r}}$$

and total impedance  $Z_2$  on rotor side is given by ,

$$Z_{2r} = \sqrt{R_2^2 + (sX_2)^2}$$

Putting this value in above equation we get,

$$I_{2r} = \frac{sE_2}{\sqrt{R_2^2 + (sX_2)^2}}$$

s = slip of [induction motor](#)

We know that [power factor](#) is defined as ratio of [resistance](#) to that of impedance. The power factor of the rotor circuit is

$$\cos \theta_{2r} = \frac{R_2}{Z_{2r}} = \frac{R_2}{\sqrt{R_2^2 + (sX_2)^2}}$$

Putting the value of [flux](#)  $\phi$ , rotor current  $I_2$ , power factor  $\cos \theta_2$  in the equation of torque we get,

$$T \propto E_2 \frac{sE_2}{\sqrt{R_2^2 + (sX_2)^2}} \times \frac{R_2}{\sqrt{R_2^2 + (sX_2)^2}}$$

Combining similar term we get,

$$T \propto sE_2^2 \frac{R_2}{R_2^2 + (sX_2)^2}$$

Removing proportionality constant we get,

$$T = K sE_2^2 \frac{R_2}{R_2^2 + (sX_2)^2}$$

*This constant*  $K = \frac{3}{2\pi n_s}$

Where,  $n_s$  is synchronous speed in r. p. s,

$$n_s = N_s / 60.$$

So, finally the equation of torque becomes,

$$T = sE_2^2 \times \frac{R_2}{R_2^2 + (sX_2)^2} \times \frac{3}{2\pi n_s} N - m$$

### **Starting torque**

The torque developed at the instant of starting of a motor is called as starting torque. Starting torque may be greater than running torque in some cases, or it may be lesser.

We know that at the start the rotor speed, N is zero.

$$\text{So, slip } s = \frac{N_s - N}{N_s} \text{ becomes } 1$$

So, the equation of starting torque is easily obtained by simply putting the value of  $s = 1$  in the equation of torque of the three phase induction motor,

$$T_{st} = \frac{k E_2^2 R_2}{R_2^2 + (X_2)^2}$$

The starting torque is also known as standstill torque.

### **Maximum Torque Condition for Three-Phase Induction Motor**

In the equation of torque,

$$T = K s E_2^2 \frac{R_2}{R_2^2 + (sX_2)^2}$$

The rotor resistance, rotor inductive reactance and synchronous speed of induction motor remain constant. The supply voltage to the [three phase induction motor](#) is usually rated and remains constant, so the stator emf also remains the constant. We define the transformation ratio as the ratio of rotor emf to that of stator emf. So if stator emf remains constant, then rotor emf also remains constant.

If we want to find the maximum value of some quantity, then we have to differentiate that quantity concerning some variable parameter and then put it equal to zero. In this case, we have to find the condition for maximum torque, so we have to differentiate torque concerning some variable quantity which is the slip, s in this case as all other parameters in the equation of torque remains constant.

So, for torque to be maximum

$$\frac{dT}{ds} = 0$$

$$\frac{d}{ds} \left[ K \frac{s E_2^2 R_2}{R_2^2 + (s X_2)^2} \right] = 0$$

$$K \frac{d}{ds} \left[ \frac{s E_2^2 R_2}{R_2^2 + (s X_2)^2} \right] = 0$$

$$K \left[ \frac{[R_2^2 + (s X_2)^2] (E_2^2 R_2) - (s E_2^2 R_2) (0 + 2s X_2 X_2)}{R_2^2 + (s X_2)^2} \right] = 0$$

$$\left\{ \text{since } \frac{d\left(\frac{U}{V}\right)}{ds} = \frac{V \frac{du}{ds} - U \frac{dv}{ds}}{V^2} \right\}$$

Now differentiate the above equation by using division rule of differentiation. On differentiating and after putting the terms equal to zero we get,

$$s^2 = \frac{R_2^2}{X_2^2}$$

Neglecting the negative value of slip we get

$$s = \frac{R_2}{X_2}$$

So, when slip  $s = R_2 / X_2$ , the torque will be maximum and this slip is called maximum slip  $S_m$  and it is defined as the ratio of rotor resistance to that of rotor reactance.

**NOTE: At starting  $S = 1$ , so the maximum starting torque occur when rotor resistance is equal to rotor reactance.**

## Equation of Maximum Torque

The equation of torque is

$$T = K s E_2^2 \frac{R_2}{R_2^2 + (sX_2)^2}$$

The torque will be maximum when slip  $S_m = R_2 / X_2$

$$T_m = \frac{k \left( \frac{R_2}{X_2} \right) E_2^2 R_2}{R_2^2 + \left( \frac{R_2}{X_2} X_2 \right)^2}$$

$$T_m = \frac{k E_2^2}{2X_2} \text{ N-m.}$$

In order to increase the starting torque, extra [resistance](#) should be added to the rotor circuit at start and cut out gradually as motor speeds up.

Conclusion

From the above equation it is concluded that

- The maximum torque is directly proportional to square of rotor induced emf at the standstill.
- The maximum torque is inversely proportional to rotor reactance.
- The maximum torque is independent of rotor resistance.
- The slip at which maximum torque occur depends upon rotor resistance,  $R_2$ . So, by varying the rotor resistance, maximum torque can be obtained at any required slip.

## Full-load Torque and Maximum Torque

Let  $s_f$  be the slip corresponding to full-load torque, then

$$T_f \propto \frac{s_f R_2}{R_2^2 + (s_f X_2)^2} \quad \text{and} \quad T_{\max} \propto \frac{1}{2 \times X_2}$$

$$\frac{T_f}{T_{\max}} = \frac{2s_f R_2 X_2}{R_2^2 + (s_f X_2)^2}$$

Dividing both the numerator and the denominator by  $X_2^2$ , we get

$$\frac{T_f}{T_{\max}} = \frac{2s_f \cdot R_2 / X_2}{(R_2 / X_2)^2 + s_f^2} = \frac{2as_f}{a^2 + s_f^2}$$

where  $a = R_2 / X_2 = \text{resistance/standstill reactance}$

## Starting Torque and Maximum Torque

$$T_d \propto \frac{R_2}{R_2^2 + X_2^2}$$

$$T_{\max} \propto \frac{1}{2 X_2}$$

$$\frac{T_d}{T_{\max}} = \frac{2R_2 X_2}{R_2^2 + X_2^2} = \frac{2R_2 / X_2}{1 + (R_2 / X_2)^2} = \frac{2a}{1 + a^2}$$

$$a = \frac{R_2}{X_2} = \frac{\text{rotor resistance}}{\text{stand still reactance}} \text{ per phase}$$

## Torque Slip Characteristics of Induction Machine

Torque Slip Characteristics is the graphical relationship between the torque and slip of an Induction Machine. This characteristic is very useful for the stability analysis of the machine.

Electromagnetic torque in an Induction Machine is given as

**Full Load Torque Expression**

$$T = \frac{k_s E_2^2 R_2}{R_2^2 + (sX_2)^2}$$

$$\text{where } k = \frac{3}{2\pi n_s}$$

$$n_s = \frac{N_s}{60} \text{ Synchronous speed in RPS}$$

$X_2$  = Rotor reactance at standstill

$E_2$  = Induced EMF in rotor at standstill

$R_2$  = Rotor resistance

$s$  = slip

From the above equation, the variation of electromagnetic torque can be plotted for different values of slip while assuming that the motor is connected to a constant frequency voltage source. This plot so obtained, also called Torque Slip Characteristics, is shown in figure below.

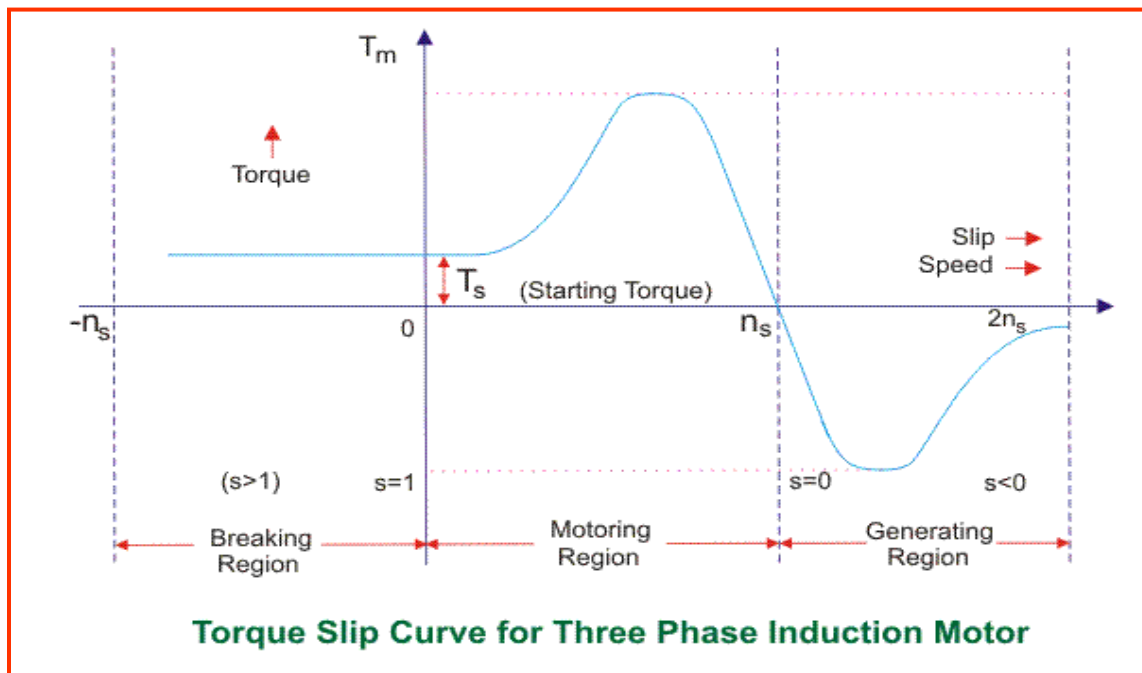

From the above, torque slip characteristics, it can be said that, there are three regions of operation of induction machine i.e. when  $s < 0$ ,  $s > 1$  and  $0 < s < 1$ . We will consider each of the regions in the following discussion.

### Case1: $0 < s < 1$ i.e. Motoring Mode

As the slip is less than 1, this means that the speed of rotor is less than synchronous speed and the rotor is rotating in the direction of rotating magnetic field. Also, electromagnetic torque for this region of operation of induction motor is positive as clear from the characteristics. This means that, this region of operation, is the normal operation of machine and that too, as Induction Motor.

It must be noted that, when  $s = 0$ , electromagnetic torque is zero just because the machine rotor is rotating at the synchronous speed in the direction of rotating magnetic flux, hence the relative speed between them is zero which causes no emf to be developed in the rotor and hence no torque is produced.

Also, note that, at the starting i.e.  $s = 1$ , there exists some finite torque, this finite torque corresponds to the no load torque requirement of the machine due to inertia of rotor and windage, friction and bearing losses.

### **Case2: $s < 0$ i.e. Generating Mode**

As the name suggest, the machine should be producing electrical power. But electrical energy can only be produced if we supply input mechanical energy, this means in Generating mode, we must be using prime mover to rotate the rotor and stator is connected to constant frequency voltage source. Now if the rotor is rotated at a speed more than the synchronous speed, the slip will be negative and as per equation (1), electromagnetic torque will be negative which means that electromagnetic torque is opposing the prime mover torque. This opposition is necessary for the conversion of mechanical energy to electrical energy.

It shall be noted that, even though rotor is rotated a super synchronous speed but stator is not connected to constant voltage source then there will not be any generation action.

### **Case3: $s > 1$ i.e. Braking Mode**

Slip more than 1 means the rotor is revolving opposite to the direction of rotating magnetic field; this means the electromagnetic torque will act in a direction opposite to the direction of rotation of rotor. But how can we achieve  $s > 1$ ?

Well, we can use prime mover and can rotate the rotor in a direction opposite to the rotating magnetic field. But this method is rarely used. Rather the practical application of  $s > 1$  is exploited in quick stopping to induction motor by just changing any of the two phase leads.

Suppose the rotor of induction motor is revolving in clockwise direction which means magnetic flux is also rotating in clockwise direction. Meanwhile we change any two phase leads. Changing the phase leads will cause change in direction of rotation of magnetic field i.e. anticlockwise direction. This change in direction of magnetic flux will cause electromagnetic torque to reverse its direction but due to inertia the rotor will continue to rotate in clockwise direction. Thus, electromagnetic torque is anticlockwise and rotor is rotating in clockwise direction. Therefore rotor will rotate in deceleration and will soon come to a stop. But as soon as the motor come to a stop, the stator must be disconnected from supply else the rotor will start rotating in anticlockwise direction. This method of Braking is known as Plugging. The Braking region in torque slip characteristics is marked in the figure below.



## Equivalent Circuit

Induction motor is a well-known device which works on the principle of transformer. So it is also called the rotating transformer.

That is, when an voltage is supplied to its stator, then as a result of electromagnetic induction, a EMF is induced in its rotor. So an induction motor is said to be a transformer with rotating secondary. Here, primary of transformer resembles stator winding of an induction motor and secondary resembles rotor.

The equivalent circuit of any machine shows the various parameter of the machine such as its ohmic losses and also other losses.

The losses are modeled just by inductor and resistor. The copper losses are occurred in the windings so the winding resistance is taken into account. Also, the winding has inductance for which there is a voltage drop due to inductive reactance and also a term called power factor comes into the picture.

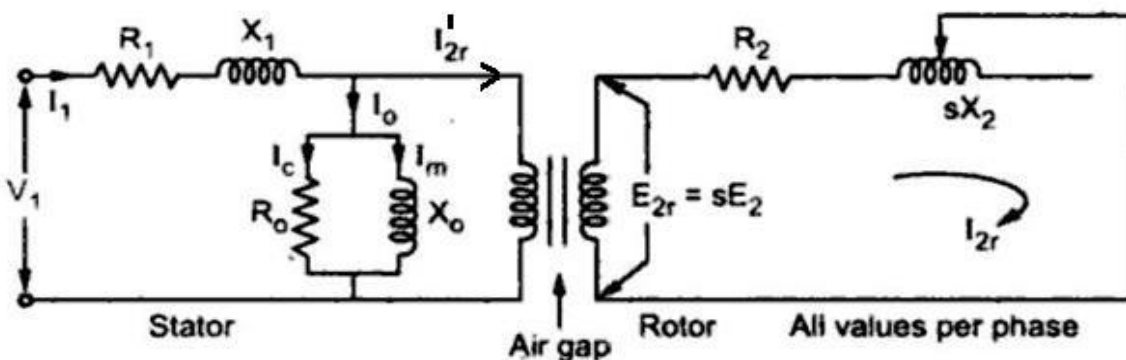
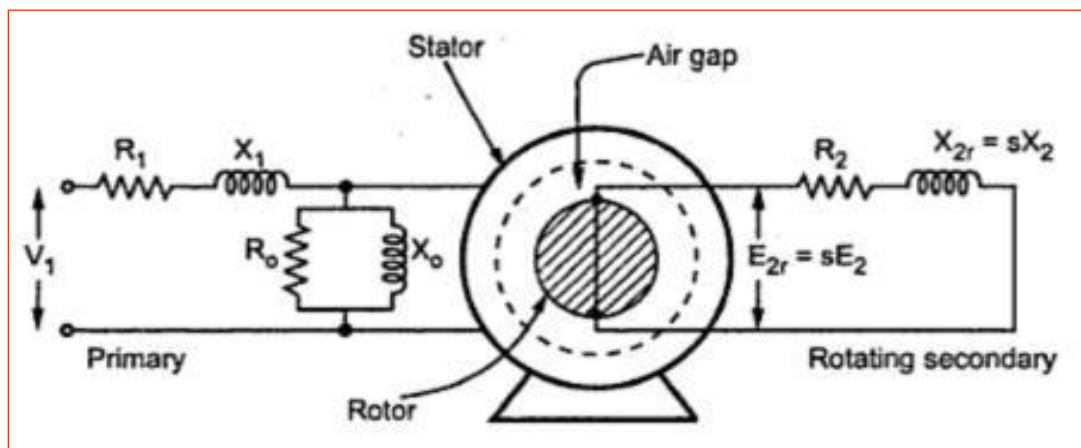

**Basic Equivalent Circuit**

Here,

- $R_1$  is the winding resistance of the stator.

- $X_1$  is the inductance of the stator winding.
- $R_0$  is the core loss component.
- $X_0$  is the magnetizing reactance of the winding.

If we draw the circuit with referred to the stator then the circuit will look like-

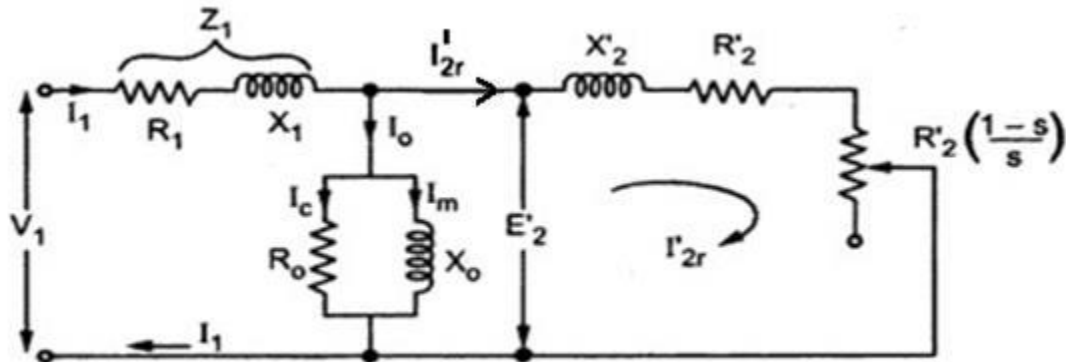

**Fig. Equivalent circuit referred to stator**

Here

- $R_2'$  is the rotor winding resistance with referred to stator winding.
- $X_2'$  is the rotor winding inductance with referred to stator winding.
- $R_2'(1 - s) / s$  is the resistance which shows the power which is converted to mechanical
- Power output or useful power.
- The power dissipated in that resistor is the useful power output or shaft power.
- The phasor diagram of loaded induction motor is similar to the loaded transformer. The only difference is the secondary of induction motor is rotating and short circuited while transformer secondary is stationary and connected to load.
- The load on induction motor is mechanical while load on transformer is electrical. Still by finding electrical equivalent of mechanical load on the motor, the phasor diagram of induction motor can be developed.

### **Phasor Diagram of Induction Motor**

The phasor diagram of loaded induction motor is similar to the loaded transformer. The only difference is the secondary of induction motor is rotating and short circuited while transformer secondary is stationary and connected to load. The load on induction motor is mechanical while load on transformer is electrical. Still by finding electrical equivalent of mechanical load on the motor, the phasor diagram of induction motor can be developed.

Let  $\Phi$  = Magnetic flux links with both primary and secondary

$E_1$  = Self induced e.m.f. in the stator

$E_{2r}$  = Mutually induced e.m.f. in the rotor.

$R_1$  = Stator resistance per phase.

$X_1$  = Stator reactance per phase

The stator voltage per phase  $V_1$  has to counter balance self induced e.m.f.  $E_1$  and has to supply voltage drops  $I_1 R_1$  and  $I_1 X_1$ . So on stator side we can write,

$$\overline{V_1} = -\overline{E_1} + \overline{I_1 R_1} + j\overline{I_1 X_1} = \overline{E_1} + \overline{I_1} (\overline{R_1} + j\overline{X_1}) = -\overline{E_1} + \overline{I_1} \overline{Z_1}$$

The rotor induced e.m.f. in the running condition has to supply the drop across impedances as rotor short circuited.

$$\therefore \overline{E_{2r}} = \overline{I_{2r} R_2} + j\overline{I_{2r} X_2} = \overline{I_{2r}} (\overline{R_2} + j\overline{X_2}) = \overline{I_{2r}} \overline{Z_{2r}}$$

The value of  $E_{2r}$  depends on the ratio of rotor turns to stator turns.

The rotor current in the running condition is  $I_{2r}$  which lags  $E_{2r}$  by rotor p.f. angle  $\Phi_{2r}$ .

The reflected rotor current  $I_{2r}'$  on stator side is the **effect of load** and is given by,

$$I_{2r}' = K I_{2r}$$

The induction motor draws no load current  $I_0$  which is phasor sum of  $I_c$  and  $I_m$ . The total stator current drawn from supply is,

$$\overline{I_1} = \overline{I_0} + \overline{I_{2r}'}$$

The  $\Phi_1$  is angle between  $V_1$  and  $I_1$  and  $\cos \Phi_1$  gives the power factor of the induction motor.

Thus using all above relations the phasor diagram of induction motor on load can be obtained.

**The steps to draw phasor diagram are,**

- 1. Takes  $\Phi$  as reference phasor.**
- 2. The induced voltage  $E_1$  lags  $\Phi$  by  $90^\circ$ .**
- 3. Show  $-E_1$  by reversing voltage phasor.**
- 4. The phasor  $E_{2r}$  is in phase with  $E_1$ . So  $I_{2r}$  show lagging  $E_{2r}$  i.e.  $E_1$  direction by  $\Phi_{2r}$ .**
- 5. Show  $I_{2r} R_2$  in phase with  $I_{2r}$  and  $I_{2r} X_{2r}$  leading the resistive drop by  $90^\circ$ , to get exact location of.**
- 6. Reverse  $I_{2r}$  to get  $I_{2r}'$ .**
- 7.  $I_m$  is in phase with  $\Phi$  while  $I_c$  is at leading with. Add  $I_m$  and  $I_c$  to get  $I_0$ .**
- 8. Add  $I_0$  and  $I_{2r}'$  to get  $I_1$ .**

9. From tip of  $-E_1$  phasor, add  $I_1 R_1$  in phase with  $I_1$  and  $I_1 X_1$  at  $90^\circ$  leading to  $I_1$  to  $V_1$  get phasor.

10. Angle between  $V_1$  and  $I_1$  is  $\Phi_1$ .

The phasor diagram is shown in the Fig.

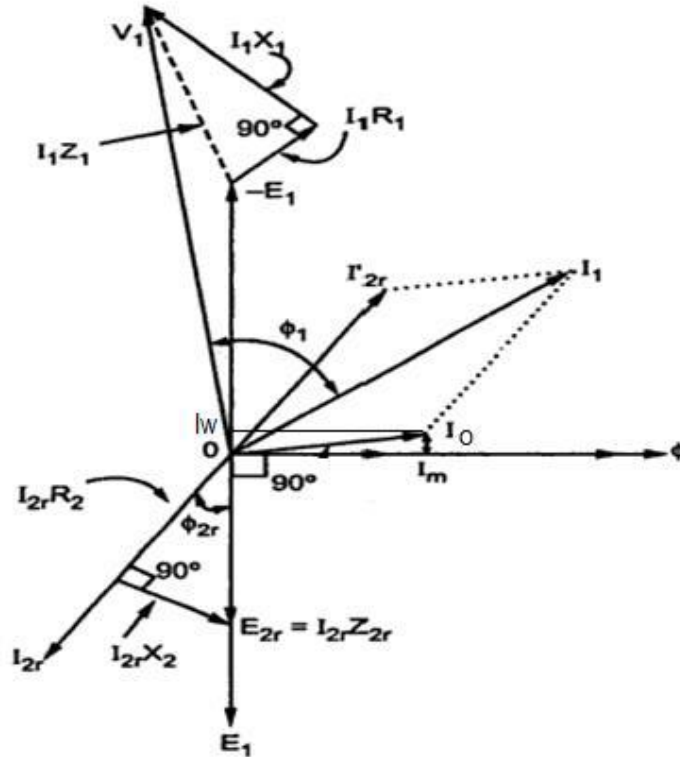

### Crawling of Induction Motor

Sometimes, squirrel cage induction motors exhibit a tendency to run at very slow speeds (as low as one-seventh of their synchronous speed). This phenomenon is called as crawling of an induction motor. This action is due to the fact that, flux wave produced by a stator winding is not purely sine wave.

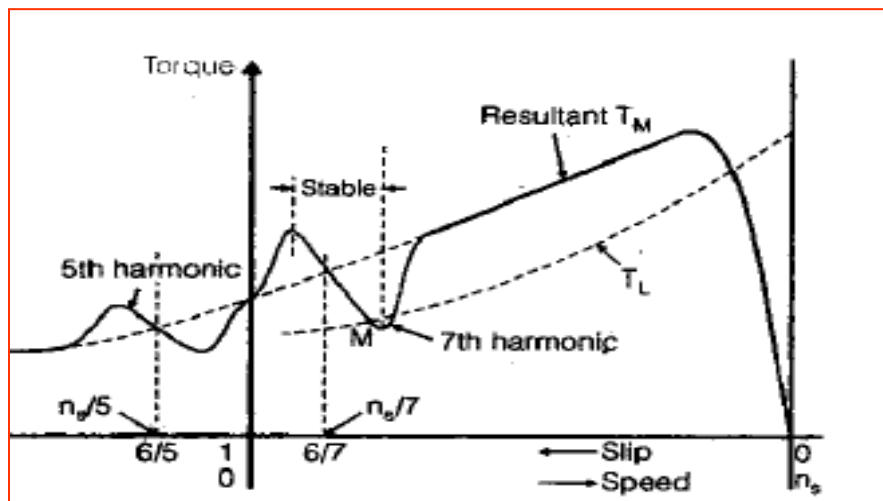

The resultant speed is nearly  $1/7$ th of its synchronous speed. Now the question arises why this happens? This action is due to the fact that harmonics fluxes produced in the gap of the stator winding of odd harmonics like 3rd, 5th, 7th etc. These harmonics create additional torque fields in addition to the synchronous torque.

The torque produced by these harmonics rotates in the forward or backward direction at  $N_s/3$ ,  $N_s/5$ ,  $N_s/7$  speed respectively. Here we consider only 5th and 7th harmonics and rest are neglected. The torque produced by the 5th harmonic rotates in the backward direction. This torque produced by fifth harmonic which works as a braking action is small in quantity, so it can be neglected. Now the seventh harmonic produces a forward rotating torque at synchronous speed  $N_s/7$ . Hence, the net forward torque is equal to the sum of the torque produced by 7th harmonic and fundamental torque. The torque produced by 7th harmonic reaches its maximum positive value just below  $1/7$  of  $N_s$  and at this point slip is high. At this stage motor does not reach up to its normal speed and continue to rotate at a speed which is much lower than its normal speed.

This causes crawling of the motor at just below  $1/7$  synchronous speed and creates the racket. The other speed at which motor crawls is  $1/13$  of synchronous speed.

### **Methods to overcome crawling**

- In cage rotor motors cogging and crawling can be reduced by proper choice of coil span and skewing (slightly twisting the rotor teeth).
- By choosing proper combination of stator and rotor slots we can minimize crawling.

### **Cogging of Induction Motor**

The phenomenon of Magnetic Locking between the stator and the rotor teeth is called Cogging or Teeth Locking. Even after applying full voltage to the stator winding, the rotor of a 3 phase induction motor fails to start.

Sometimes it happens because of low supply voltage. But the main reason for starting problem in the motor is because of cogging in which the slots of the stator get locked up with the rotor slots. As we know that there is series of slots in the stator and rotor of the induction motor. When the slots of the rotor are equal in number with slots in the stator, they align themselves in such way that both face to each other and at this stage the reluctance of the magnetic path is minimum and motor refuse to start. This characteristic of the induction motor is called cogging. Apart from this, there is one more reason for cogging.

If the harmonic frequencies coincide with the slot frequency due to the harmonics present in the supply voltage then it causes torque modulation. As a result, cogging occurs. This characteristic is also known as magnetic teeth locking of the induction motor.

### Methods to overcome Cogging

This problem can be easily solved by adopting several measures. These solutions are as follows:

- The number of slots in rotor should not be equal to the number of slots in the stator.
- Skewing of the rotor slots, that means the stack of the rotor is arranged in such a way that it angled with the axis of the rotation.

### NO LOAD AND BLOCKED ROTOR TESTS

These two tests are performed to predetermine the performance characteristics of the motor at any load. Predetermine means finding or estimating the performance of motor at any specified load without actually loading it. Actually by performing the no-load and blocked rotor test where we supply only a small amount of energy to supply core loss and copper loss, we can obtain the parameters of the equivalent circuit of the motor, from which we obtain its performance characteristics.

#### No-Load test or Open-Circuit Test:

- The no-load test of an induction motor is similar to the open-circuit test of a transformer.
- The motor is not connected from its load, and the rated voltage at the rated frequency is applied to the stator to run the motor without a load.
- The 2-wattmeter method measures the input power of the system.

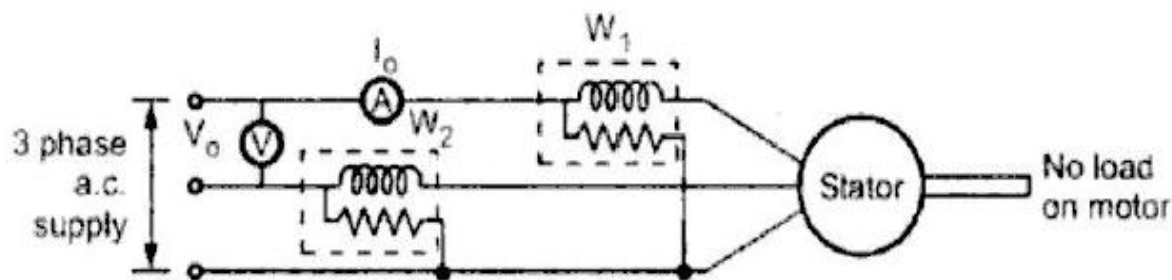

**Fig. No load test**

**Figure: Circuit diagram for no-load test on a 3-phase induction motor.**

- The voltmeter measures the standard-rated supply voltage and an ammeter measures the no-load current.

- Since the motor is running at no-load, total power is equal to the constant iron loss, friction and winding losses of the motor.

The total power input  $W_o$  is the algebraic sum of the two wattmeter readings. The observation table is,

$V_o$ volts Rated line voltage	$I_o$ Amp No load current	$W_o = W_1 + W_2$ (Algebraic sum) in watts

The calculations are,

$$W_o = \sqrt{3} V_o I_o \cos \phi_o$$

$$\therefore \cos \phi_o = \frac{W_o}{\sqrt{3} V_o I_o} \quad \text{where } V_o, I_o \text{ are line values}$$

This is **no load power factor**.

- Since the power factor of the induction motor under a no-load condition is generally less than 0.5, one wattmeter will show a negative reading. Therefore, it is, necessary to reverse the direction of current-coil terminals to take the reading.

$V_o$  = input line voltage

$W_o$  = total 3-phase input power at no-load

$I_o$  = input line current.

$W_{in} = \sqrt{3} V_o I_o \cos \Phi_o$

$I_w = I_o \cos \Phi_o$

$I_\mu = I_o \sin \Phi_o$

$R_o = V_o / I_w$

$X_o = V_o / I_\mu$

### **Blocked Rotor or Short-Circuit Test:**

- The blocked rotor test of an induction motor is same as the short-circuit test of a transformer.
- In this test, the shaft of the motor is connected so that it cannot move and rotor winding is short-circuited.
- In a slip-ring motor, the rotor winding is short-circuited through slip-rings and in cage motors, the rotor bars are permanently short-circuited. This test is also called the locked-Rotor test.

If under short circuit condition

- $\Rightarrow$  Primary is excited with rated voltage  $\Rightarrow$  A large short circuit current can flow which is dangerous from the windings point of view.
- So similar to the transformer short circuit test  $\Rightarrow$  The reduced voltage (about 5 to 10% of rated voltage) just enough such that stator carries rated current is applied.

$V_{sc}$  = Short circuit reduced voltage (Line value)

$I_{sc}$  = Short circuit current (Line value)

$W_{sc}$  = Short circuit input power

$$W_{sc} = \sqrt{3} V_{sc} I_{sc} \cos \Phi_{sc}$$

$$\Rightarrow \cos \Phi_{sc} = W_{sc} / \sqrt{3} V_{sc} I_{sc}$$

This is the short circuit power factor.

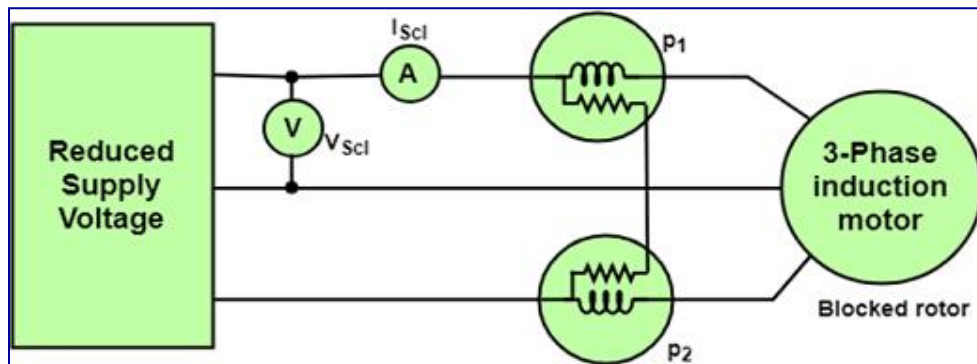

**Figure: Circuit diagram for blocked rotor test**

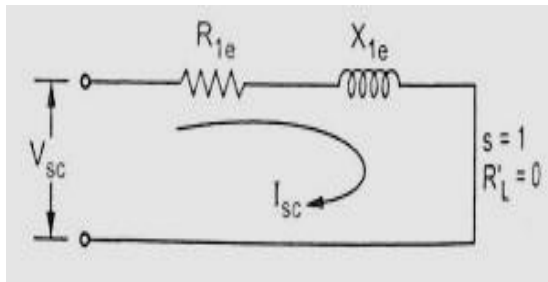

$$\Rightarrow W_{sc} = 3 (I_{sc})^2 R_{1e}$$

Where  $I_{sc}$  per phase value.

$\Rightarrow$  (Equivalent resistance referred to stator)

$$R_{1e} = W_{sc} / 3 (I_{sc})^2$$

$$Z_{1e} = V_{sc} \text{ (Per phase)} / I_{sc} \text{ (Per phase)}$$

$\Rightarrow$  (Equivalent reactance referred to stator)

$$X_{1e} = \sqrt{(Z_{1e})^2 - (R_{1e})^2}$$



► **Example 5.36 :** A 50 Hz, 8 pole induction motor has full load slip of 4 %. The resistance/phase = 0.01 Ω and stand still reactance per phase = 0.1 Ω. Find the ratio of maximum to full load torque and the speed at which maximum torque occurs.

[Madras Univ. April 2000]

**Solution :** The given values are

$$P = 8, f = 50 \text{ Hz}, s_f = 4 \% = 0.04$$

$$R_2 = 0.01 \Omega$$

$$X_2 = 0.1 \Omega$$

Now,  $T \propto \frac{sR_2}{R_2^2 + (sX_2)^2}$  with  $E_2$  constant

$$T_{F.L.} \propto \frac{s_f R_2}{R_2^2 + (s_f X_2)^2}$$

and  $T_m \propto \frac{s_m R_2}{R_2^2 + (s_m X_2)^2}$

$$s_m = \frac{R_2}{X_2} = \frac{0.01}{0.1} = 0.1$$

Taking ratio of  $T_{F.L.}$  and  $T_m$

$$\begin{aligned} \frac{T_m}{T_{F.L.}} &= \frac{s_m R_2}{R_2^2 + (s_m X_2)^2} \cdot \frac{R_2^2 + (s_f X_2)^2}{s_f R_2} \\ &= \frac{s_m [R_2 + (s_f X_2)^2]}{s_f [R_2 + (s_m X_2)]^2} = \frac{0.1 [0.01 + (0.04 \times 0.1)^2]}{0.04 [0.01 + (0.1 \times 0.1)^2]} \\ &= 2.48 \end{aligned}$$

$$s_m = 0.1 = \text{Slip at which } T_m \text{ occurs}$$

$$N_s = \frac{120 f}{P} = \frac{120 \times 50}{8} = 750 \text{ r.p.m.}$$

$$N = N_s (1 - s_m)$$

$$= 750 (1 - 0.1) = 750 (0.9)$$

$$\therefore N = 675 \text{ r.p.m.}$$

This is the speed at which maximum torque occurs.

## Features of Motor Starters

Today, motor starters are used on a large scale due to their list of beneficial features. The following are some features of these highly useful electrical devices:

1. They facilitate the starting and stopping of the motor.
2. The starters are rated by power (horsepower, kilowatt) and current (amperes).
3. They provide the necessary overload protection for the motor.
4. The electrical device facilitates remote on/off control feature.
5. These devices allow you to make and break current rapidly (plugging and jogging).

## Fundamental Functions of Motor Starters

The following are the most fundamental functions that a starter has to perform:

1. **Control:** The control function is mainly carried out by the contactor component of a starter. It is controlling the opening and closing of the power electrical circuit. The switching is done by the main contacts (poles) of the contactor. An electromagnetic coil is energized, which open or close the contacts. This electromagnetic coil has a nominal control voltage, and can either be an AC or DC voltage.
2. **Short-Circuit Protection:** In industrial applications, normal load current can be up to thousands of amperes. In the case of a short-circuit fault, the fault current can go over 100,000 amperes. This can cause severe damage to the equipment. The short-circuit protection disconnects the supply and prevents the potential damage in a safe manner. Short circuit protection is provided by fuses or circuit breakers in a Combination Motor Controller.
3. **Overload Protection:** When a motor draws more current than it is designed to, an overload condition is caused. The main objective of an overload relay is to detect the excess currents. When an overload is detected, the auxiliary contact of the overload relay opens the circuit and prevents the motor from burning out or overheating. Electronic or electromechanical overload relays are used in combination with a contactor to provide the required overload protection.
4. **Disconnecting and Breaking:** In order to prevent an unintended restart, it is required to disconnect the motor from the main power circuit. In order to safely perform maintenance on a motor or starter, a motor must be able to switch off and be isolated from the power. The disconnect switch of the circuit provides this function. Disconnecting and breaking is provided by a disconnect switch or circuit breaker in a Combination Motor Controller (or can be installed remotely from the starter).

## NECESSITY OF A STARTER IN A THREE PHASE INDUCTION MOTOR

The three phase induction motors are self starting due to rotating magnetic field. But the motors have a tendency to draw very high current at the time of starting. **Such a current can be five to eight times the rated current and can damage the motor winding.** Hence a starter is used which can limit such high starting current. In a three phase induction motor, the magnitude of an induced e.m.f. in the rotor circuit depends on the slip of the induction motor. This induced e.m.f. effectively decides the magnitude of the rotor current. The rotor current in the running condition is given by,

$$I_{2r} = \frac{sE_2}{\sqrt{R_2^2 + (sX_2)^2}}$$

At start, the speed of the motor is zero and slip is at its maximum i.e. unity. So magnitude of rotor induced e.m.f. is very large at start. As rotor conductors are short circuited, the large induced e.m.f. circulates very high current through rotor at start. In a three phase induction motor, when rotor current is high, the stator draws a very high current from the supply. This current can be of the order of 5 to 8 times the full load current, at start.

Due to such heavy inrush of current at start

- There is possibility of damage of the motor winding.
- Causes large line voltage.
- Other appliances connected to the same line may be subjected to voltage spikes which may affect their working.

To avoid such effects, it is necessary to limit the current drawn by the motor at start. The starter is a device which is basically used to limit high starting current by supplying reduced voltage to the motor at the time of starting. Such a reduced voltage is applied only for short period and once rotor gets accelerated, full normal rated voltage is applied.

### Functions of a Starter:

- limits the starting current
- provides the protection against overloading
- Provides the protection against low voltage situations.
- provides protection against single phasing

## FOUR TYPES OF STARTING METHODS ARE EMPLOYED:

There are primarily two methods of starting the induction motor:-

a) Full voltage starting.

b) Reduced voltage starting.

**Full voltage starting methods consist of:-**

i) DOL (Direct-on-line) starting

**Reduced voltage starting methods consists of:-**

i) Stator resistor starting.

ii) Auto-transformer starting.

iii) Star-delta starting.

**For slip ring Induction motor:-**

i) Rotor resistance starting

Squirrel Cage Induction Motor	Slip Ring Induction Motor
<ul style="list-style-type: none"><li>• DOL (Direct-on-line) starting</li><li>• Stator resistor starting (Primary resistors)</li><li>• Auto-transformer starting</li><li>• Star-delta starting.</li></ul>	<ul style="list-style-type: none"><li>• DOL (Direct-on-line) starting</li><li>• Stator resistor starting (Primary resistors)</li><li>• Auto-transformer starting</li><li>• Star-delta starting.</li><li>• Rotor resistance starting</li></ul>

**i. DOL (Direct-on-line starting)**

### Working Of Direct On Line Starter

If large rating induction motors are connected directly to the supply, a heavy starting current can damage the motor and also cause disturbance of voltage, i.e., voltage dip on mains supply. This can lead malfunctioning of other equipments connected to the same supply.

Thus DOL starters are limited to small rating motors where distribution system (mains supply) can withstand high starting currents without excessive voltage dips.

DOL starter consists of MCCB, contactor, and overload relay. It acts as a switch under normal working condition by providing the means to switch ON and switch OFF the motor.

The wiring diagram for a DOL starter is shown below. A direct online starter consists of two buttons, a GREEN button for starting and a RED for stopping purpose of the motor. The **DOL starter** comprises of an MCCB or [circuit breaker](#), contactor and an overload relay for protection. These two buttons, i.e. Green and Red or start and stop buttons control the contacts.

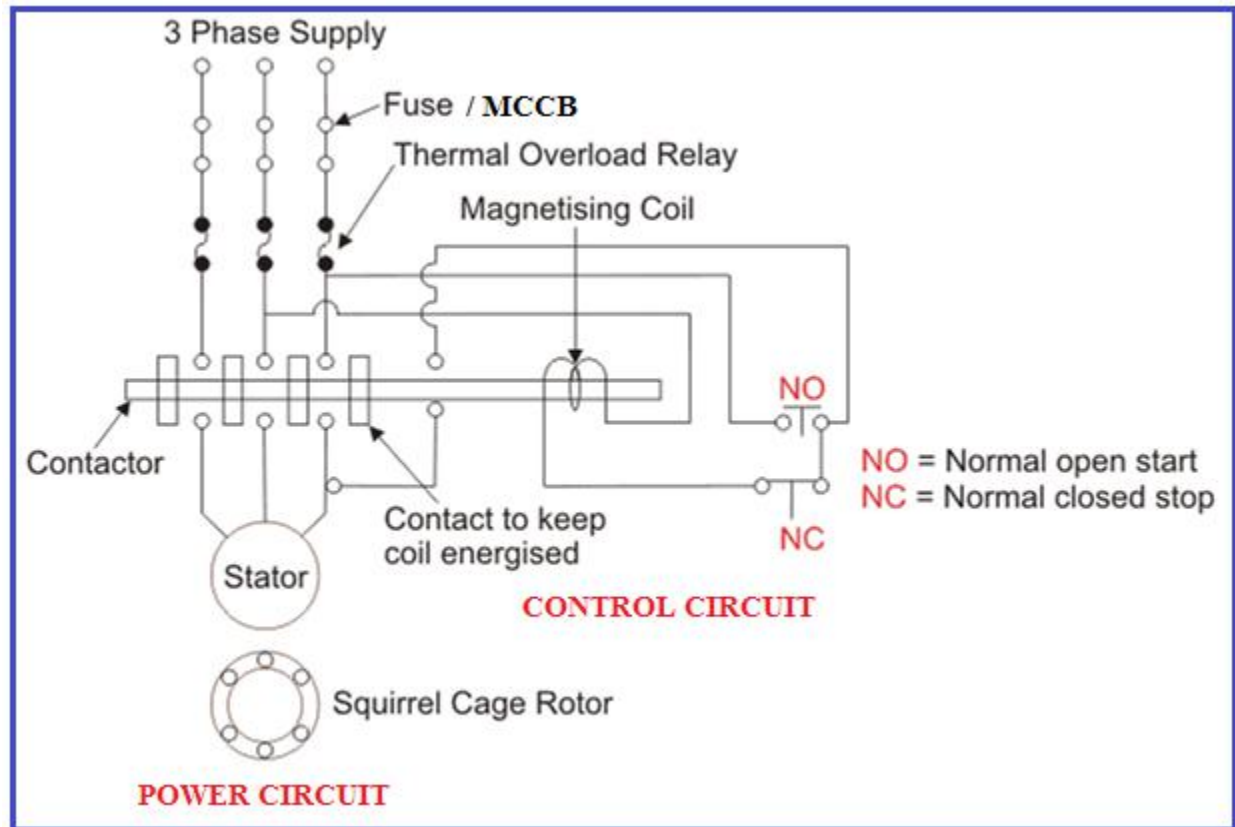

When the start button is pressed, current will flow through one phase to the control circuit and the contactor coil to the other phase. This current energizes the contactor coil which makes to close the contacts thereby three phase supply is connected to the motor. Since the start button is of pushbutton, when it is released the control circuit still maintains the supply through hold-on contact.

If we press the stop button, the current through the contact becomes discontinued, hence supply to the motor will not be available, and the similar thing will happen when the overload relay operates. Since the supply of motor breaks, the machine will come to rest. The contactor coil (Magnetizing Coil) gets supply even though we release start button because when we release start button, it will get supply from the primary contacts as illustrated in the diagram of the Direct Online Starter.

The thermal overload protection relay operates depending on the heating effect of the load current. When the load current heats the thermal coils, bimetallic strip inside of it expands such that it trips out the spring-loaded contact in the control circuit. The speed at which relay operates decided by the current adjustment. Typically it will be four to five times the rated motor current.

### **Advantages of DOL Starter**

1. Simple and most economical starter.
2. More comfortable to design, operate and control.
3. Provides nearly full starting torque at starting.
4. Easy to understand and troubleshoot.
5. DOL starter connects the supply to the delta winding of the motor.

### **Disadvantages of DOL Starter**

1. High starting current (5-8 times of full load current).
2. DOL Starter causes a significant dip in voltage, hence suitable only for small motors.
3. **DOL Starter** reduces the lifespan of the machine.
4. Mechanically tough.
5. Unnecessary high starting torque

### **DOL Starter Applications**

- The applications of DOL starters are primarily motors where a high inrush current does not cause excessive voltage drop in the supply circuit (or where this high voltage drop is acceptable).
- Direct on line starters are commonly used to start small water pumps, conveyor belts, fans, and compressors. In the case of an asynchronous motor (such as the 3-phase squirrel-cage motor) the motor will draw a high starting current until it has run up to full speed.

#### **i. Stator resistor starting.**

In order to apply the reduced voltage to the stator of the induction motor, three resistances are added in series with each phase of the stator winding. Initially the resistances are kept maximum in the circuit. Due to this, large voltage gets dropped across the resistances. Hence a reduced voltage gets applied to the stator which reduces the high starting current. The schematic diagram showing stator resistances is shown in the Fig.

When the motor starts running, the resistances are gradually cut-off from the stator circuit. When the resistances are entirely removed from the stator circuit i.e. rheostats in RUN position then rated voltage gets applied to the stator Motor runs with normal speed.

- The starter is simple in construction and cheap.
- It can be used for both star and delta connected stator.
- Large power losses due to resistances.
- The starting torque of the motor reduces due to reduced voltage applied to the stator.

Given below is the figure for the starting [resistor](#) method:

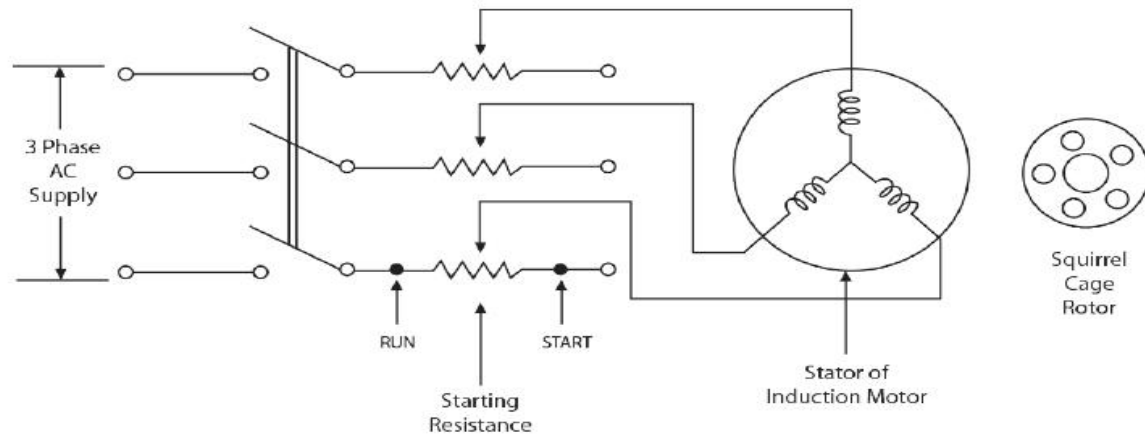

- In this method we add resistor or a reactor in each phase as shown in the diagram (between the motor terminal and the supply mains). Thus by adding resistor we can control the supply voltage.
- Only a fraction of the voltage ( $x$ ) of the supply voltage is applied at the time of starting of the [induction motor](#). The value of  $x$  is always less than one.
- Due to the drop in the voltage the starting torque also decreases.
- We will derive the expression for the starting torque in terms of the voltage fraction  $x$  in order to show the variation of the starting torque with the value of  $x$ .
- As the motor speeds up the reactor or resistor is cut out from the circuit and finally the resistors are short circuited when the motor reaches to its operating speed.
- Now let us derive the expression for starting torque in terms of full load torque for the stator resistor starting method.
- Here various quantities that involved in the expression for the starting torques are written below:

$T_s$  as starting torque

$T_f$  as full load torque

$I_f$  as per phase rotor current at full load

$I_s$  as per phase rotor current at the time of starting

$S_f$  as full load slip

$S_s$  as starting slip

$R_2$  as rotor resistance

$N_s$  as synchronous speed of the motor

- Now we can directly write the expression for [torque of the induction motor](#) as

$$T = \frac{1}{N_s} \times I_s^2 \frac{R}{s}$$

From the help of the above expression we write the ratio of starting torque to full load torque as

$$\frac{T_s}{T_f} = \left( \frac{I_s}{I_f} \right)^2 \times s_f \dots \dots (i)$$

- Here we have assumed that the rotor resistance is constant and it does not vary with the frequency of the rotor current.
- From the above equation we can have the expression for the starting torque in terms of the full load torque.

Now at the time of starting the per phase voltage is reduced to  $xV_1$ , the per phase starting current is also reduced to  $xI_s$ . On substituting the value of  $I_s$  as  $xI_s$  in equation 1. We have

$$\frac{T_s}{T_f} = \left( \frac{xI_s}{I_f} \right)^2 \times s_f$$

$$\frac{T_s}{T_f} = \left( \frac{I_s}{I_f} \right)^2 \times s_f \times x^2$$

This shows the variation of the starting torque with the value of  $x$ . Now there are some considerations regarding this method. If we add series resistor then the energy losses are increased so it's better to use series reactor in place of resistor because it is more effective in reducing the voltage however series reactor is more costly than the series resistance.

### **The Advantages of Using Stator Resistance Motor Starters:**

- They are suitable for use in speed control applications.
- They have extremely flexible starting characteristics.
- They provide smooth acceleration.



## ii. Auto Transformer Starting Method

As the name suggests in this method we connect [auto transformer](#) in between the three phase power supply and the [induction motor](#) as shown in the given diagram:

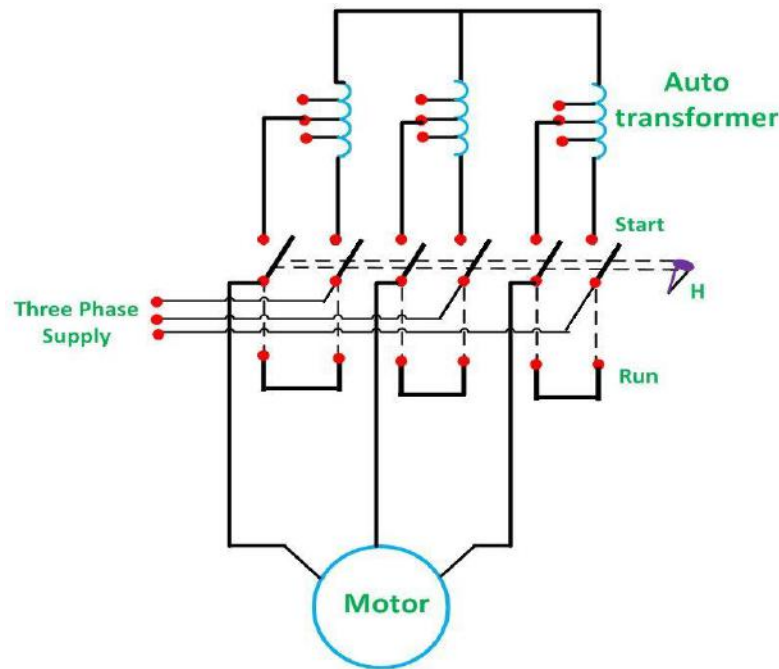

Circuit Globe

- An **Auto transformer Starter** is suitable for both star and delta connected motors.
- In this method, the starting current is limited by using a three-phase auto transformer to reduce the initial stator applied voltage.
- The figure above shows the motor with the **Auto transformer starter**.
- It is provided with a number of tapings. The starter is connected to one particular tapping to obtain the most suitable starting voltage.
- A double throw switch S is used to connect the auto transformer in the circuit for starting.
- When the **handle H** of the switch S in the **START** position.
- The primary of the auto transformer is connected to the supply line, and the motor is connected to the secondary of the auto transformer.
- When the motor picks up the speed of about 80 percent of its rated value, the handle H is quickly moved to the RUN position. Thus, the auto transformer is disconnected from the circuit, and the motor is directly connected to the line and achieve its full rated voltage. The handle is held in the RUN position by the under voltage relay.
- If the supply voltage fails or falls below a certain value, the handle is released and returns to the OFF position. Thermal overload relays provide the overload protection.

### The Advantages of Using Auto Transformer Motor Starters:

- They can be used for manual speed control, but with limited options.
- They have extremely flexible starting characteristics.
- They have a high output torque.

### iii. Star Delta Starter

The **Star Delta Starter** is a very common type of starter and is used extensively as compared to the other type of starting methods of the induction motor. A star delta is used for a cage motor designed to run normally on the delta connected stator winding. The connection of a three-phase induction motor with a star delta starter is shown in the figure below.

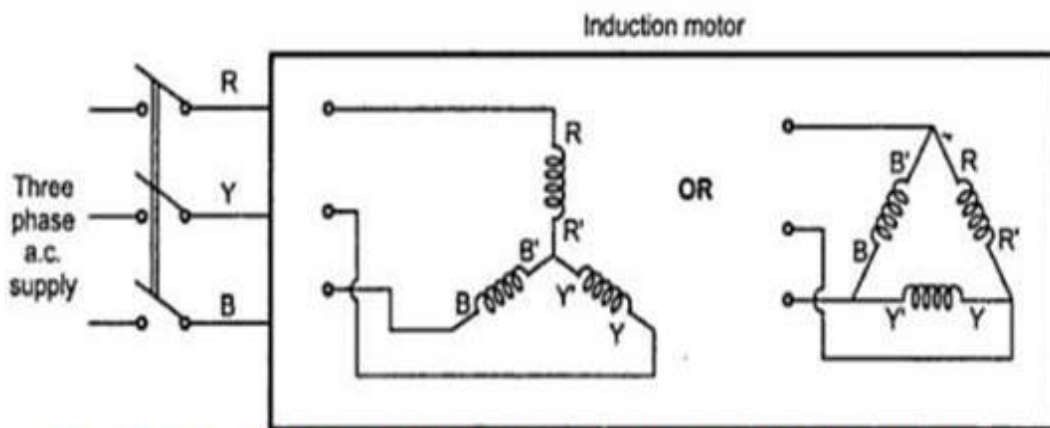

STAR OR DELTA CONNECTED THREE PHASE STATOR WINDING

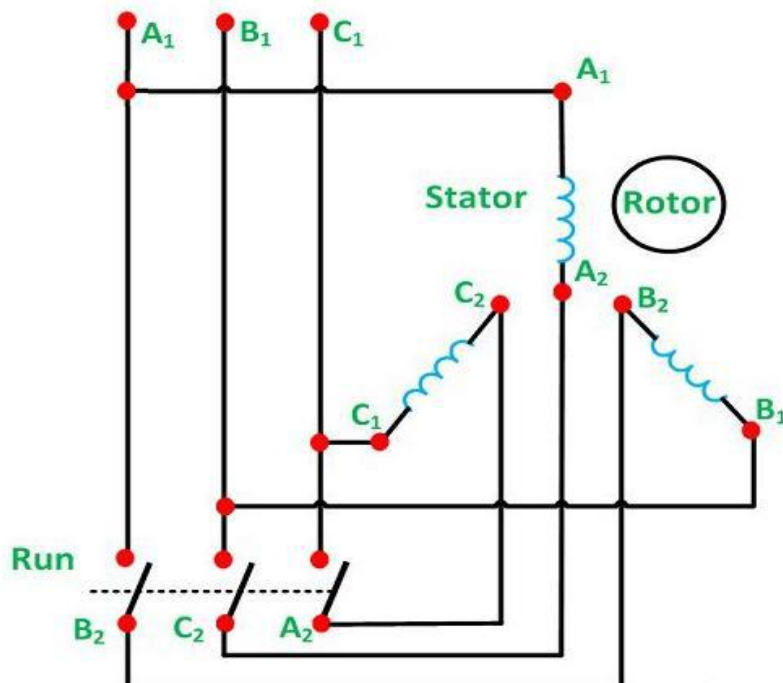

When the switch S is in the **START** position, the stator windings are connected in the star as shown below.

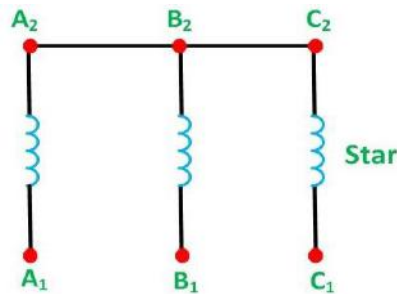

When the motor picks up the speed, about 80 percent of its rated speed, the switch S is immediately put into the **RUN** position. As a result, a stator winding which was in star connection is changed into **DELTA** connection now. The delta connection of the stator winding is shown in the figure below.

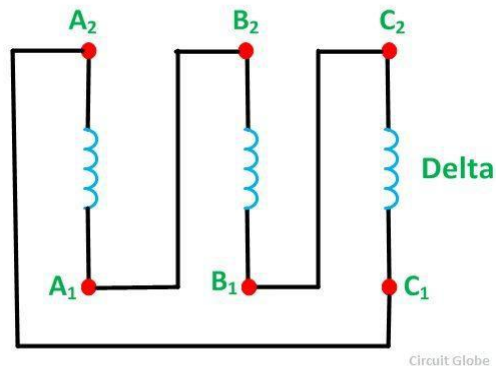

Firstly, the stator winding is connected in star and then in Delta so that the starting line current of the motor is reduced to one-third as compared to the starting current with the windings connected in delta. At the starting of an induction motor when the windings of the stator are star connected, each stator phase gets a voltage  $V_L/\sqrt{3}$ . Here  $V_L$  is the line voltage.

Since the developed torque is proportional to the square of the voltage applied to an induction motor. Star delta starter reduces the starting torque to one-third that is obtained by direct delta starting.

#### **The Advantages of Using Star Delta Motor Starters:**

- They are ideal for long acceleration times.
- They have a lower input surge current when compared to other starters.
- They have a simpler construction as compared to other starters.

### i. Rotor resistance starting

- In a slip-ring (wound rotor) induction motor, resistance can be inserted in the rotor circuit via slip rings, so as to increase the starting torque.
- The starting current in the rotor winding is

$$(I_2)_{st} = \frac{E_r}{\sqrt{(r_2 + R_{ext})^2 + (x_2)^2}}$$

where  $R_{ext}$  = Additional resistance per phase in the rotor circuit.

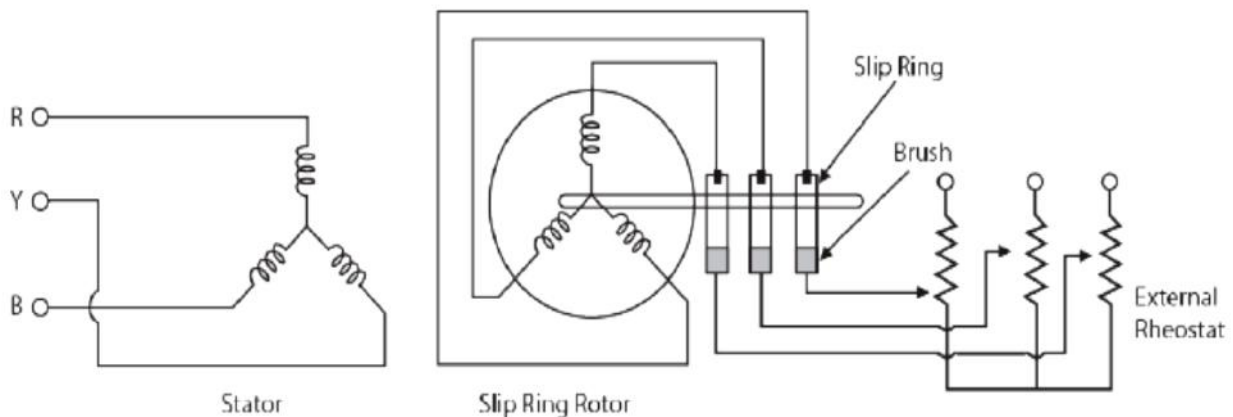

- The input (stator) current is proportional to the rotor current as shown earlier. The starting current (input) reduces, as resistance is inserted in the rotor circuit.
- But the starting torque,

$$[(T_0)_{st} = 3 \cdot [(I_2)_{st}]^2 \cdot (r_2 + R_{ext})]$$

increases, as the total resistance in the rotor circuit is increased.

- Though the starting current decreases, the total resistance increases, thus resulting in increase of starting torque.
- If the additional resistance is used only for starting, being rated for intermittent duty, the resistance is to be decreased in steps, as the motor speed increases. Finally, the external resistance is to be completely cut out, i.e. to be made equal to zero, thus leaving the slip-rings short-circuited.
- Here, also the additional cost of the external resistance with intermittent rating is to be incurred, which results in decrease of starting current, along with increase of starting torque, both being advantageous.

- Also it may be noted that the cost of a slip-ring induction is higher than that of IM with cage rotor, having same power rating.
- So, in both cases, additional cost is to be incurred to obtain the above advantages. This is only used in case higher starting torque is needed to start IM with high load torque.

### **The Advantages of Using Rotor Resistance Motor Starters:**

- They are cost-effective.
- They have a simple speed control method.
- They provide low starting current, large starting torque, and large pull-out torque.

### **SPEED CONTROL OF THREE PHASE INDUCTION MOTOR**

- An Induction motor is practically a constant speed motor that means, for the entire loading range, change in speed of the motor is quite small.
- Speed of a DC shunt motor can be varied very easily with good efficiency, but in case of Induction motors, speed reduction is accompanied by a corresponding loss of efficiency and poor power factor.
- The speed control of induction motor is done at the cost of decrease in efficiency and low electrical power factor.
- As induction motors are widely being used, their speed control may be required in many applications.

**We know that**

$$S = \frac{N_s - N}{N_s}$$

$$N = N_s(1 - S)$$

$$N_s = \frac{120f}{P}$$

$$N = \frac{120f}{P}(1 - S)$$

**N = Rotor speed or speed of Induction motor**

**N<sub>s</sub> = Synchronous speed**

**Speed of Induction motor depends on**

- i) slip**
- ii) Frequency of supply**
- iii) Number of poles for which the windings are made**

Different speed control methods of induction motor are explained below.

The speed control of three phase induction motor from **stator side** is classified as:

1. Controlling supply voltage (SCIM and SRIM)
2. Constant V / f control or frequency control (SCIM and SRIM)
3. Changing the number of stator poles (SCIM)
4. Adding rheostat in the stator circuit. (SCIM and SRIM)

The speed controls of three phase induction motor from **rotor side** are classified as:

1. Adding external resistance on rotor side (SRIM)
2. Cascade control method.
3. Injecting slip frequency emf into rotor side (SRIM)

## SPEED CONTROL FROM STATOR SIDE

### 1. Controlling Supply Voltage

The torque produced by running three phase induction motor is given by

$$T \propto \frac{sE_2^2 R_2}{R_2^2 + (sX_2)^2}$$

Rotor resistance  $R_2$  is constant and for low slip region  $(sX)^2$  is very very small as compared to  $R_2$ . So, it can be neglected.

So torque becomes

$$T \propto \frac{sE_2^2}{R_2}$$

Since rotor resistance,  $R_2$  is constant so the equation of torque further reduces to

$$T \propto sE_2^2$$

We know that Rotor induced emf  $E_2 \propto V$ .

So,  $T \propto sV^2$

- The equation above clears that if we decrease supply voltage torque will also decrease. But for providing the same load torque, the torque must remain the same, and it is only possible if we increase the slip and if the slip increases the motor will run at a reduced speed.
- This method, though the cheapest and the easiest, is rarely used because
- A large change in voltage is required for a relatively small change in speed

- Due to reduction in voltage, current drawn by the motor increases. Due to increased current, the motor may get overheated.
- This large change in voltage will result in a large change in the flux density thereby seriously disturbing the magnetic conditions of the motor.

## 2. V / f Control or Frequency Control

Whenever three phase supply is given to three phase induction motor rotating magnetic field is produced which rotates at synchronous speed given by

$$N_s = \frac{120f}{P}$$

In three phase induction motor emf is induced by induction similar to that of transformer which is given by

$$E_1 = V = 4.44\phi f N_1 K_w$$

$$\phi = \frac{V}{4.44 f N_1 K_w}$$

Where  $N_1$  is the number of series turns per phase in stator (constant)

$f$  is supply frequency

$K_w$  is winding factor (constant)

$$\phi \propto \frac{V}{f}$$

- Now if we change frequency synchronous speed changes but **with decrease in frequency flux will increase and this increase in value of flux causes saturation of rotor and stator cores which will further cause increase in no load current of the motor** .
- So, it is important to maintain flux,  $\phi$  constant and it is only possible if we change voltage. i.e if we decrease frequency flux increases but at the same time if we decrease voltage flux will also decrease causing no change in flux and hence it remains constant.
- So, here we are keeping the ratio of V/f as constant. Hence its name is V/ f method. For controlling the speed of three phase induction motor by V/f method we have to supply variable voltage and frequency which is easily obtained by using converter and inverter set.

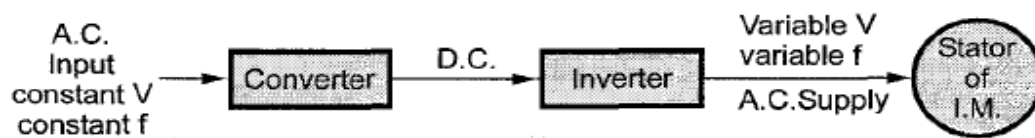

### 3. Changing the number of stator poles:

The stator poles can be changed by two methods

a. Consequent poles method

b. Multiple stator winding method.

c. Pole amplitude modulation method (PAM)

#### a. Consequent poles method

In this method, connections of the stator winding are changed with the help of simple switching. Due to this, the number of stator poles gets changed in the ratio 2:1. Hence either of the two synchronous speeds can be selected.

Consider the pole formation due to single phase of a three phase winding, as shown in the Fig. There are three tapping points to the stator winding. The supply is given to two of them and third is kept open.

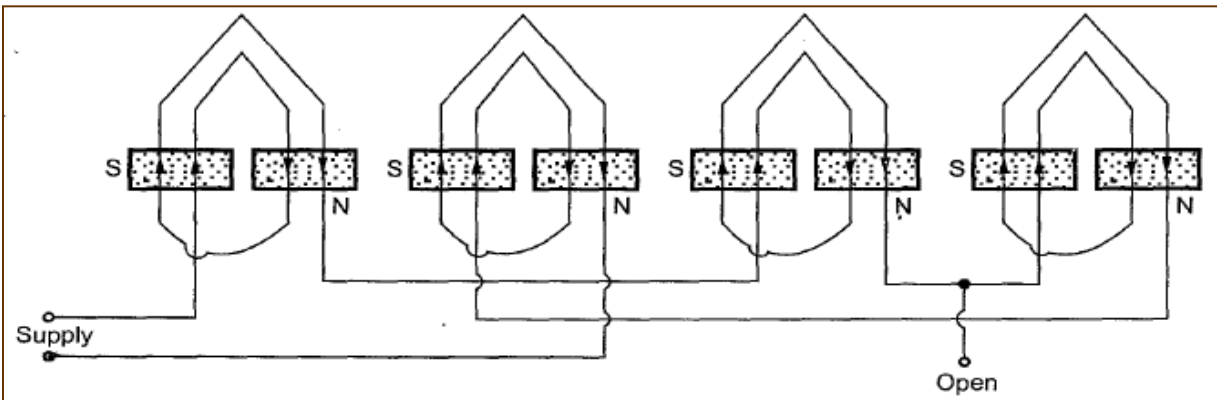

Fig.1

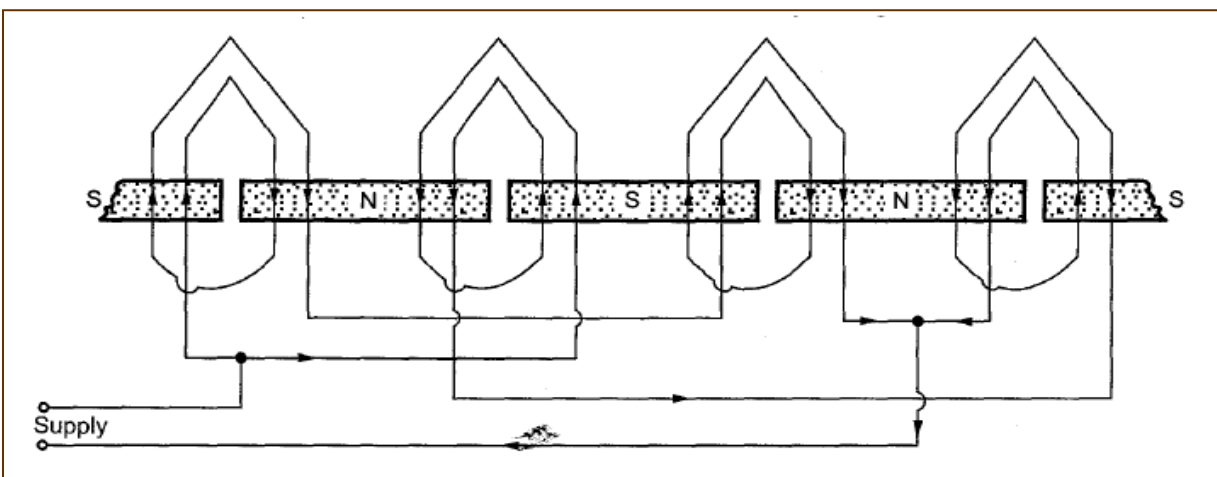

Fig.2



The current in all the parts of stator coil is flowing in one direction only. Due to this, 8 poles get formed as shown in the Fig.1 So synchronous speed possible with this arrangement with 50 Hz frequency is  $N = 750$  r.p.m.

If the two terminals to which supply was given earlier are joined together and supply is given between this common point and the open third terminal, the poles are formed as shown in the Fig.2

The direction of current through two coils is different than the direction of current through remaining two. Thus upward direction is forming say S pole and downward say N. In this case only 4 poles are formed. So the synchronous speed possible is 1500 r.p.m. for 50 Hz frequency.

### **Disadvantage**

1. The speed change is in step and smooth speed control is not possible.
2. The method can be used only for the squirrel cage type motors as squirrel cage rotor adjusts itself to same number of poles as stator which is not the case in slip ring induction motor.

### **Applications**

Elevators, traction motors and small motors to drive machine tools.

### **b. Multiple Stator Winding Method**

In this method of speed control of three phase induction motor, we provide two separate windings in the stator. These two stator windings are electrically isolated from each other and are wound for two different numbers of poles. Using a switching arrangement, at a time, supply is given to one winding only and hence speed control is possible. Disadvantages of this method are that the smooth speed control is not possible. This method is more costly and less efficient as two different stator windings are required. This method of speed control can only be applied to squirrel cage motor.

### **Limitations**

1. Can be applied to only squirrel cage motor.
2. Smooth speed control is not possible. Only step changes in speed are possible.
3. Two different stator windings are required to be wound which increases the cost of the motor.
4. Complicated from the design point of view.

### **c. Pole Amplitude Modulation Method (PAM)**

In this method of speed control of three phase induction motor the original sinusoidal mmf wave is modulated by another sinusoidal mmf wave having the different number of poles.

Let

$f_1(\theta)$  be the original mmf wave of induction motor whose speed is to be controlled.

$f_2(\theta)$  be the modulation mmf wave.

$P_1$  be the number of poles of induction motor whose speed is to be controlled.

$P_2$  be the number of poles of modulation wave.

$$f_1(\theta) = F_1 \sin \frac{P_1 \theta}{2}$$

$$f_2(\theta) = F_2 \sin \frac{P_2 \theta}{2}$$

After modulation resultant mmf wave

$$F_r(\theta) = F_1 F_2 \sin \frac{P_1 \theta}{2} \sin \frac{P_2 \theta}{2}$$

$$\text{Apply formula for } 2 \sin A \sin B = \cos \frac{A - B}{2} - \cos \frac{A + B}{2}$$

So we get, resultant mmf wave

$$F_r(\theta) = F_1 F_2 \frac{\cos \frac{(P_1 - P_2)\theta}{2} - \cos \frac{(P_1 + P_2)\theta}{2}}{2}$$

Therefore the resultant mmf wave will have two different number of poles

$$\text{i.e } P_{11} = P_1 - P_2 \text{ and } P_{12} = P_1 + P_2$$

Therefore by changing the number of poles we can easily change the speed of three phase induction motor.

#### **4. Adding Rheostat in Stator Circuit**

In this method of speed control of three phase induction motor rheostat is added in the stator circuit due to this voltage gets dropped. In case of three phase induction motor torque produced is given by  $T \propto sV_2^2$ . If we decrease supply voltage torque will also decrease. But for supplying the same load, the torque must remain the same and it is only possible if we increase the slip and if the slip increases the motor will run at reduced speed.

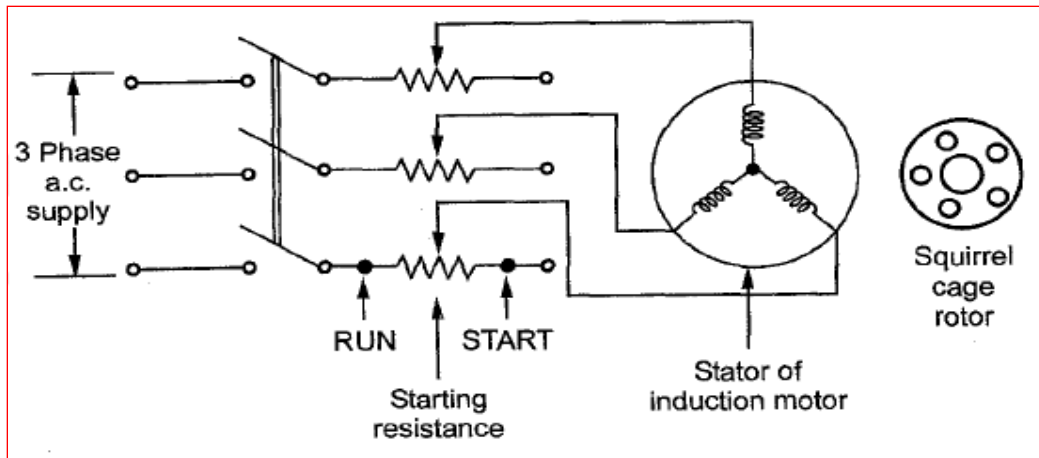

## SPEED CONTROL FROM ROTOR SIDE

### 1. Adding External Resistance on Rotor Side

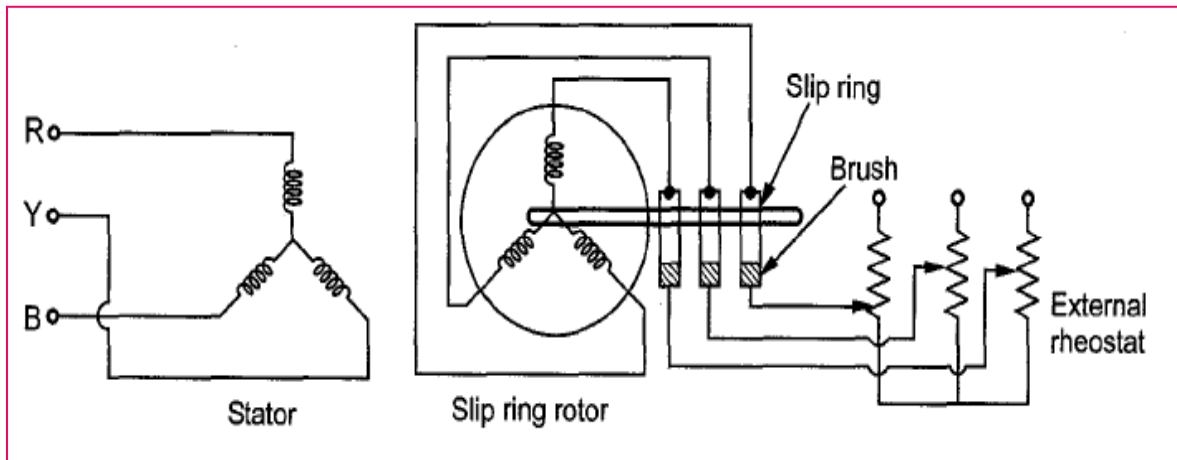

In this method of speed control of three phase induction motor external resistance are added on rotor side. The equation of torque for three phase induction motor is

$$T \propto \frac{sE_2^2 R_2}{R_2^2 + (sX_2)^2}$$

The three-phase induction motor operates in a low slip region. In low slip region term  $(sX)^2$  becomes very very small as compared to  $R_2$ . So, it can be neglected. And also  $E_2$  is constant.

So the equation of torque after simplification becomes,

$$T \propto \frac{s}{R_2}$$

Now if we increase rotor resistance,  $R_2$  torque decreases but to supply the same load torque must remain constant. So, we increase slip, which will further result in the decrease in rotor speed.

Thus by adding additional resistance in the rotor circuit, we can decrease the speed of the three-phase induction motor.

### Advantage

- By increasing the rotor resistance  $R_2$  speeds below normal value can be achieved.
- The starting torque of the motor increases proportional to rotor resistance.

### Disadvantage

- The large speed changes are not possible. This is because for large speed change, large resistance is required to be introduced in rotor which causes large rotor copper loss to reduce the efficiency.
- The method cannot be used for the squirrel cage induction motors.
- The speeds above the normal values cannot be obtained.
- Large power losses occur due to large  $I^2R$  loss.
- Sufficient cooling arrangements are required which make the external rheostats bulky and expensive.
- Due to large power losses, efficiency is low.

## 2. Cascade Control Method

In this method of speed control of three phase induction motor, the two three-phase induction motors are connected on a common shaft and hence called cascaded motor. One motor is called the main motor (motor A), and another motor is called the auxiliary motor (motor B). The three-phase supply is given to the stator of the main motor and the other motor is fed from the induced emf in first motor via slip-rings. The arrangement is as shown in following fig.

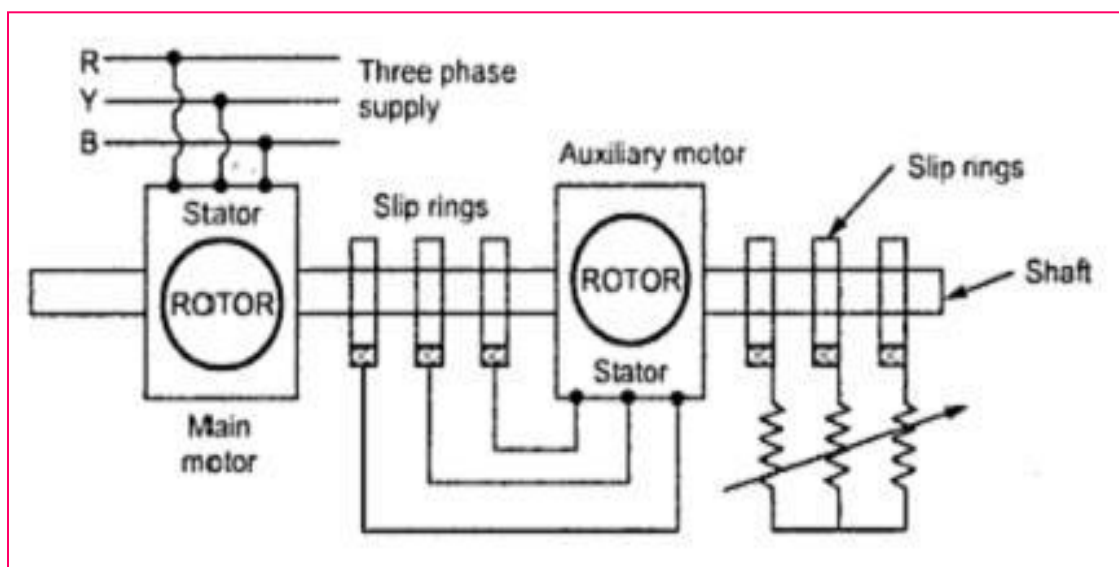

Let,  $N_{s1}$  = Synchronous Speed of motor A

$N_{s2}$  = Synchronous Speed of motor B

$P_1$  = number of poles stator of motor A

$P_2$  = number of stator poles of motor B

$N$  = speed of the set and same for both motors

$f$  = frequency of the supply

$f_1 = S_1 f$  = frequency of rotor induced emf of motor A

$f_1 = S_1 f$  = frequency of emf (voltage) applied to stator of motor B

Now,

$$N_{s1} = (120f) / P_1 \text{ -----(1)}$$

Slip of motor A,

$$S_1 = (N_{s1} - N) / N_{s1}$$

frequency of the rotor induced emf in motor A,

$$f_1 = S_1 f$$

Now, auxiliary motor B is supplied with the rotor induce emf

therefore,  $N_{s2} = (120f_1) / P_2$

$$N_{s2} = (120S_1 f) / P_2 \text{ -----(2)}$$

now putting the value of  $S_1 = (N_{s1} - N) / N_{s1}$  in equation (2)

$$N_{s2} = \frac{120f(N_{s1} - N)}{P_2 N_{s1}}$$

$$N_{s2} = \frac{120f}{P_2} \left[ \frac{N_{s1} - N}{N_{s1}} \right]$$

$$N_{s2} = \frac{120f}{P_2} \left[ \frac{N_{s1}}{N_{s1}} - \frac{N}{N_{s1}} \right]$$

$$= \frac{120f}{P_2} \left[ 1 - \frac{N}{N_{s1}} \right]$$

$$N_{s2} = \frac{120f}{P_2} - \frac{120f}{P_2} \frac{N}{N_{s1}}$$

Now, At no load rotor speed of auxiliary motor is almost equal to its synchronous speed

$$N = N_{s2}$$

$$N = \frac{120f}{P_2} - \frac{120f}{P_2} \frac{N}{N_{s1}}$$

$$N = \frac{120f}{P_2} - \frac{120f}{P_2} \times \frac{N \times P_1}{120f} \quad \left[ \because N_{s1} = \frac{120f}{P_1} \right]$$

$$\frac{120f}{P_2} = N + \frac{N P_1}{P_2}$$

$$\frac{120f}{P_2} = N \left[ 1 + \frac{P_1}{P_2} \right]$$

$$\frac{120f}{P_2} = N \left[ \frac{P_2 + P_1}{P_2} \right]$$

$$N = \frac{120f}{P_1 + P_2}$$

With this method, four different speeds can be obtained

1. when only motor A works, corresponding speed =  $N_{s1} = 120f / P_1$
2. when only motor B works, corresponding speed =  $N_{s2} = 120f / P_2$
3. if commulative cascading is done, speed of the set =  $N = 120f / (P_1 + P_2)$
4. if differential cascading is done, speed of the set =  $N = 120f / (P_1 - P_2)$

## Disadvantages

1. It requires two motors which makes the set expensive.
2. Smooth speed control is not possible.
3. Operation is complicated.
4. The starting torque is not sufficient to start the set.
5. Set cannot be operated if  $P1 = P2$ .

## 3. Injecting Slip Frequency EMF into Rotor Side

When the speed control of three phase induction motor is done by adding resistance in **rotor circuit**, some part of power called, the slip power is lost as  $I^2R$  losses. Therefore the efficiency of three phase induction motor is reduced by this method of speed control. This slip power loss can be recovered and supplied back to improve the overall efficiency of the three-phase induction motor, and this scheme of recovering the power is called slip power recovery scheme and this is done by connecting an external source of emf of slip frequency to the rotor circuit. The injected emf can either oppose the rotor induced emf or aids the rotor induced emf.

In this method, a voltage is injected in the rotor circuit. The frequency of rotor circuit is a slip frequency and hence the voltage to be injected must be at a slip frequency.

$$T = \frac{SE_2^2}{R_2} = \text{CONSTANT}$$

$$T = \frac{SE_r^2}{R_2} = \text{CONSTANT}$$

$E_r = \text{resultant emf or net emf}$

$E_r = E_2 + E_i$  injected emf is inphase with induced emf of rotor

$E_r = E_2 - E_i$  injected emf is phase opposition to the induced emf of rotor

In order to maintain torque constant, if emf  $E_r$  is change, Slip  $S$  is also change and there by speed  $N$  is changed.

The injected emf (voltage) may oppose the rotor induced e.m.f. or may assist the rotor induced e.m.f.

*Let us assume the emf injected ( $E_i$ ) at slip frequency is in phase with the emf induced ( $E_2$ ) which is already at slip frequency is injected into rotor circuit as a net emf ( $E_r = E_2 + E_i$ ) is increased automatically the slip should decrease to balance the torque. So when slip is decrease means the slip speed ( $N_s - N$ ) is decreased or  $N$  is increased.*

*Let us assume the emf injected ( $E_i$ ) at slip frequency is in phase opposition to the emf induced ( $E_2$ ) which is already at slip frequency is injected into rotor circuit as a net emf ( $E_r = E_2 - E_i$ ) is decreased automatically the slip should increase to balance the torque. So when slip is increased means the slip speed ( $N_s - N$ ) is increased or  $N$  is decreased.*

- If it is in the phase opposition effective rotor resistance increases.
- If it is in the phase of rotor induced e.m.f., effective rotor resistance decreases.

Thus by controlling the magnitude of the injected e.m.f., rotor resistance and effectively speed can be controlled. Practically two methods are available which use this principle. These methods are,

1. Kramer system
2. Scherbius system

### 1. KRAMER SYSTEM

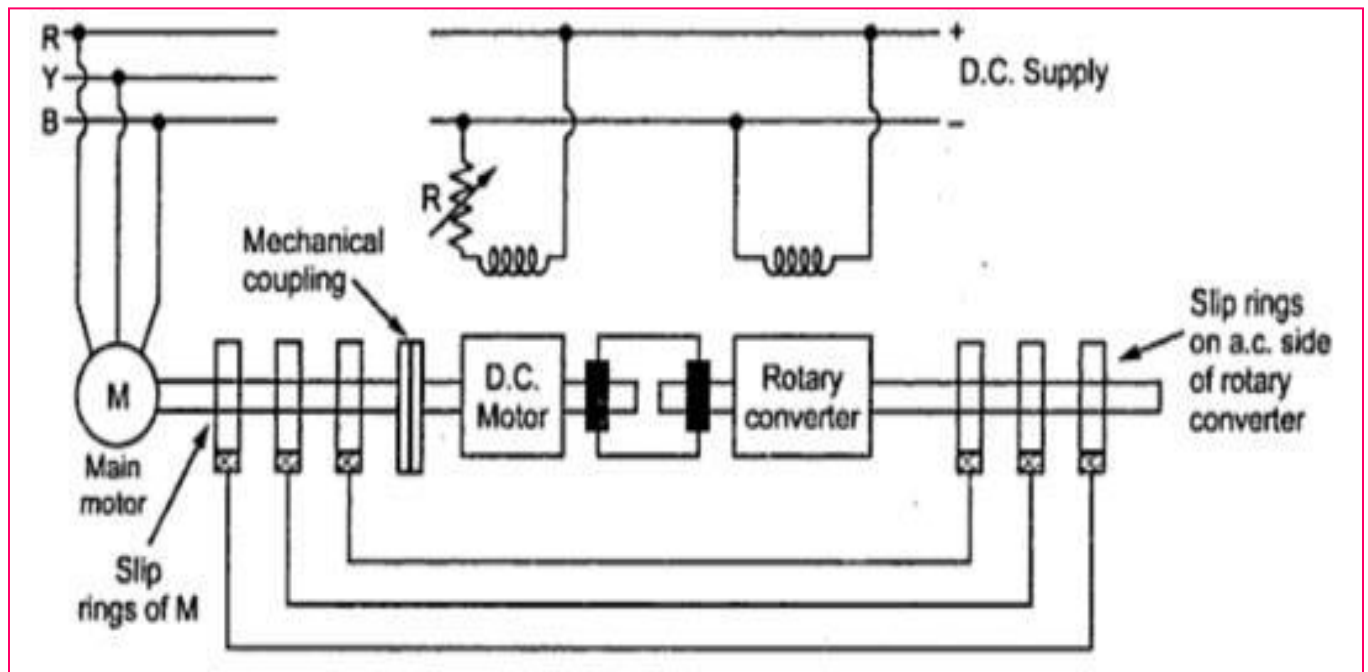

- It consists of main induction motor M, the speed of which is to be controlled. The two additional equipments are, d.c. motor and a rotary converter.
- The slip rings of the main motor are connected to the a.c. side of a rotary converter.
- The d.c. side of rotary converter feeds a d.c. shunt motor commutator, which is directly connected to the shaft of the main motor.



- A separate d.c. supply is required to excite the field winding of d.c. motor and exciting winding of a rotary converter.
- The variable resistance is introduced in the field circuit of a d.c. motor which acts as a field regulator.
- The speed of the set is controlled by varying the field of the d.c. motor with the rheostat R.
- When the field resistance is changed, the back e.m.f. of motor changes. Thus the d.c. voltage at the commutator changes. This changes the d.c. voltage on the d.c. side of a rotary converter.
- Now rotary converter has a fixed ratio between its a.c. side and d.c. side voltages. Thus voltage on its a.c. side also changes.
- This a.c. voltage is given to the slip rings of the main motor.
- So the voltage injected in the rotor of main motor changes which produces the required speed control.

### Advantages

- smooth speed control is possible
- wide range of speed control is possible
- the design of a rotary converter is practically independent of the speed control required
- if rotary converter is overexcited, it draws leading current and thus power factor improvement is also possible along with the necessary speed control
- Very large motors above 4000 kW such as steel rolling mills use such type of speed control.

## 2. SCHERBIUS SYSTEM

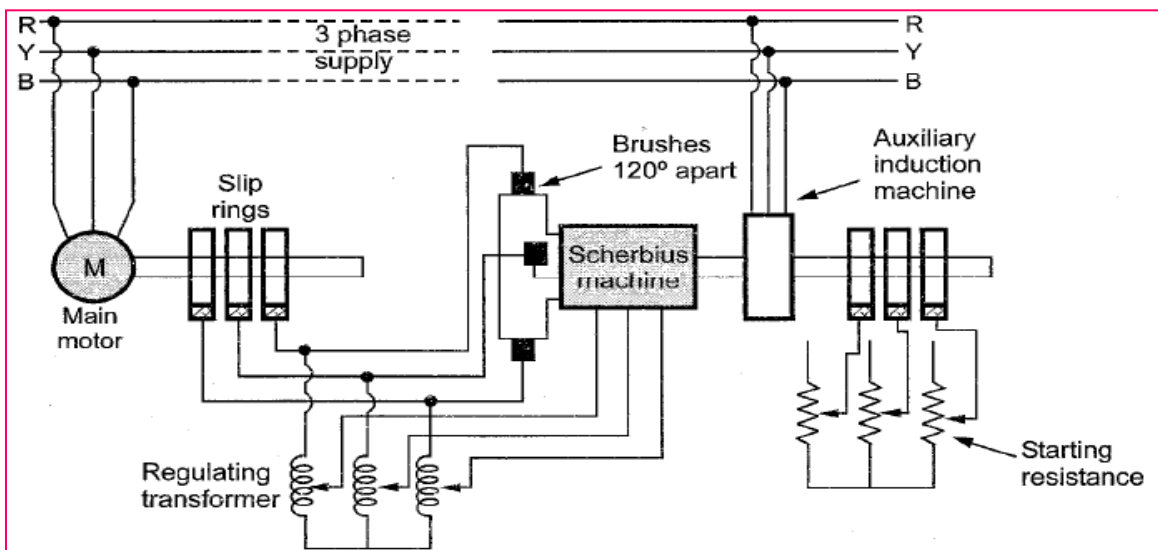

- This method requires an auxiliary 3 phase or 6 phase a.c. commutator machine which is called Scherbius machine.
- The difference between Kramer system and this system is that the Scherbius machine is not directly connected to the main motor, whose speed is to be controlled.
- The Scherbius machine is excited at slip frequency from the rotor of a main motor through a regulating transformer.
- The taps on the regulating transformer can be varied, this changes the voltage developed in the rotor of Scherbius machine, which is injected into the rotor of main motor. This controls the speed of the main motor.
- The Scherbius machine is connected directly to the induction motor supplied from main line so that its speed deviates from a fixed value only to the extent of the slip of the auxiliary induction motor.
- For any given setting of the regulating transformer, the speed of the main motor remains substantially constant irrespective of the load variations.

**Example 35.29.** The rotor of a 4-pole, 50-Hz slip-ring induction motor has a resistance of  $0.30 \Omega$  per phase and runs at 1440 rpm. at full load. Calculate the external resistance per phase which must be added to lower the speed to 1320 rpm, the torque being the same as before.

(Advanced Elect. Machines AMIE Sec.E1992)

**Solution.** The motor torque is given by  $T = \frac{K s R_2}{R_2^2 + (s X_2)^2}$

Since,  $X_2$  is not given,  $T = \frac{K s R_2}{R_2^2} = \frac{K s}{R_2}$

54303

In the first case,  $T_1 = K s_1 / R_2$ ; in the second case,  $T_2 = K s_2 / (R_2 + r)$

where  $r$  is the external resistance per phase, added to the rotor circuit

Since  $T_1 = T_2 \quad \therefore K s_1 / R_2 = K s_2 / (R_2 + r)$  or  $(R_2 + r) / R_2 = s_2 / s_1$

Now,  $N_s = 120 \times 50 / 4 = 1500$  rpm;  $N_1 = 1440$  rpm;  $N_2 = 1320$  rpm

$\therefore s_1 = (1500 - 1440) / 1500 = 0.04$ ;  $s_2 = (1500 - 1320) / 1500 = 0.12$

$\therefore \frac{0.3 + r}{0.3} = \frac{0.12}{0.04} \quad \therefore r = 0.6 \Omega$

**Example 35.30.** A certain 3-phase, 6-pole, 50-Hz induction motor when fully-loaded, runs with a slip of 3%. Find the value of the resistance necessary in series per phase of the rotor to reduce the speed by 10%. Assume that the resistance of the rotor per phase is 0.2 ohm.

(Electrical Engineering-II (M), Bangalore Univ. 1989)

**Solution.**  $T = \frac{K s R_2}{R_2^2 + (s X_2)^2} = \frac{K_s R_2}{R_2^2} = \frac{K s}{R_2}$  - neglecting  $(s X_2)$

$\therefore T_1 = K s_1 / R_2$  and  $T_2 = K s_2 / (R_2 + r)$  where  $r$  is the external resistance per phase added to the rotor circuit.

Since  $T_1 = T_2$ ,  $K s_1 / R_2 = K s_2 / (R_2 + r)$  or  $(R_2 + r) / R_2 = s_2 / s_1$

Now,  $N_s = 120 \times 50 / 6 = 1000$  rpm.,  $s_1 = 0.03$ ,  $N_1 = 1000 (1 - 0.030) = 970$  rpm.

$N_2 = 970 - 10\% \text{ of } 970 = 873$  rpm.,  $s_2 = (1000 - 873) / 1000 = 0.127$

$\therefore \frac{0.2 + r}{0.2} = \frac{0.127}{0.03}; \quad r = 0.65 \Omega.$

**Example 35.34.** A cascaded set consists of two motors A and B with 4 poles and 6 poles respectively. The motor A is connected to a 50-Hz supply. Find

- (i) the speed of the set
- (ii) the electric power transferred to motor B when the input to motor A is 25 kW. Neglect losses. (Electric Machines-I, Utkal Univ. 1990)

**Solution.** Synchronous speed of the set is\*

$$N_{sc} = 120 f / (P_a + P_b) = 120 \times 50 / (6 + 4) = \mathbf{600 \text{ r.p.m.}}$$

(ii) The outputs of the two motors are proportional to the number of their poles.

$$\therefore \text{output of 4-pole motor B} = 25 \times 4/10 = \mathbf{10 \text{ kW}}$$

**AC MACHINES**  
**(20A02402T)**

**UNIT-III**  
**Synchronous Generators**

**LECTURE NOTES**

## UNIT – IV

### SYNCHRONOUS GENERATORS

#### Contents

- Principle and Constructional Features of Salient Pole and Round Rotor Machines
- Armature Windings, Concentrated and Distributed Windings, Integral Slot and Fractional Slot Windings – Pitch, Distribution, and Winding Factors
- E.M.F Equation
- Harmonics in Generated E.M.F – Space and Slot Harmonics
- Elimination of Harmonics
- Armature Reaction – Synchronous Reactance and Impedance
- Load Characteristics - Phasor Diagram

#### Key Differences between Alternator & DC Generator

1. An alternator is a machine which converts the mechanical energy from a prime mover into the AC, whereas the generator converts the mechanical energy from the prime mover into an AC or DC.
2. The alternator induces the AC, whereas the generator causes both the AC and DC power. The generator produces the alternating current which is converted into DC by the help of the commutator.
3. The alternator has a rotating magnetic field, whereas the generator has a rotating magnetic field for the high voltage generation and low voltage stationary magnetic field is used.
4. The alternator takes input supply from the stator whereas the generator takes input supply from the rotor.
5. The armature of an alternator is stationary, and in the case of the generator, it is rotating.
6. The output EMF of the alternator is variable, and the output voltage of the generator is constant.
7. The alternator has a wide range of RPM whereas the generator has a narrow range of RPM (rotation per minute).
8. The alternator does not charge the completely dead battery whereas the generator charges the dead battery.
9. The output of the alternator is higher than that of the generator.

The alternator is smaller in size and requires less space whereas the generator requires large space.

A synchronous generator is a machine which produces AC power with rotating in a synchronous speed. It is also called as Alternator. **Alternators have the Armature winding on stator and the field winding on the rotor, not like other DC generator which have the armature winding on its rotor.** Armature winding is placed on stator by which the sparking problem reduced or almost neglected at the time of taking output to load.

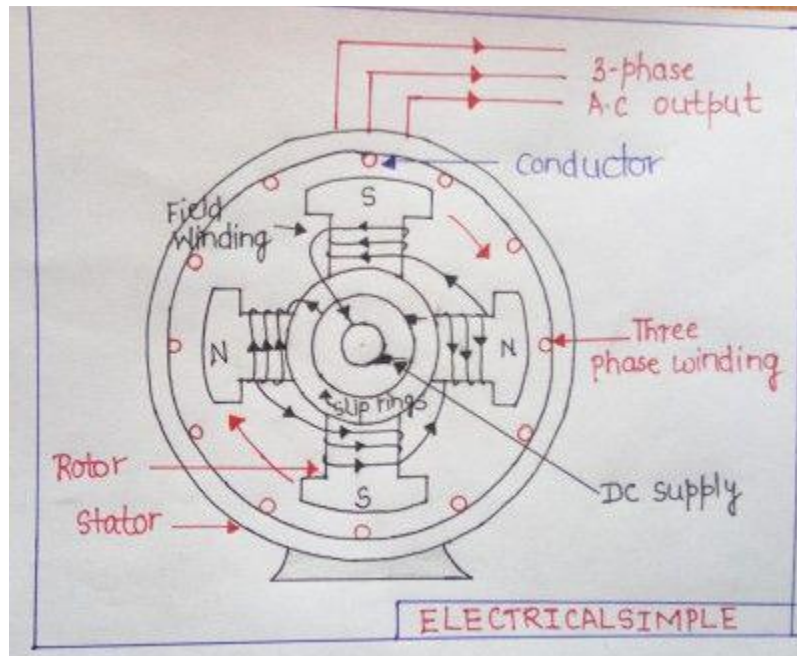

### Working Principle of Alternator

All the alternators work on the principle of electromagnetic induction. According to this law, for producing the electricity we need a conductor, magnetic field and mechanical energy. Every machine that rotates and reproduces Alternating Current. To understand the working principle of the alternator, consider two opposite magnetic poles north and south, and the flux is traveling between these two magnetic poles. In the figure (a) rectangular coil is placed between the north and south magnetic poles. The position of the coil is such that the coil is parallel to the flux, so no flux is cutting and therefore no current is induced. So that the waveform generated in that position is Zero degrees.

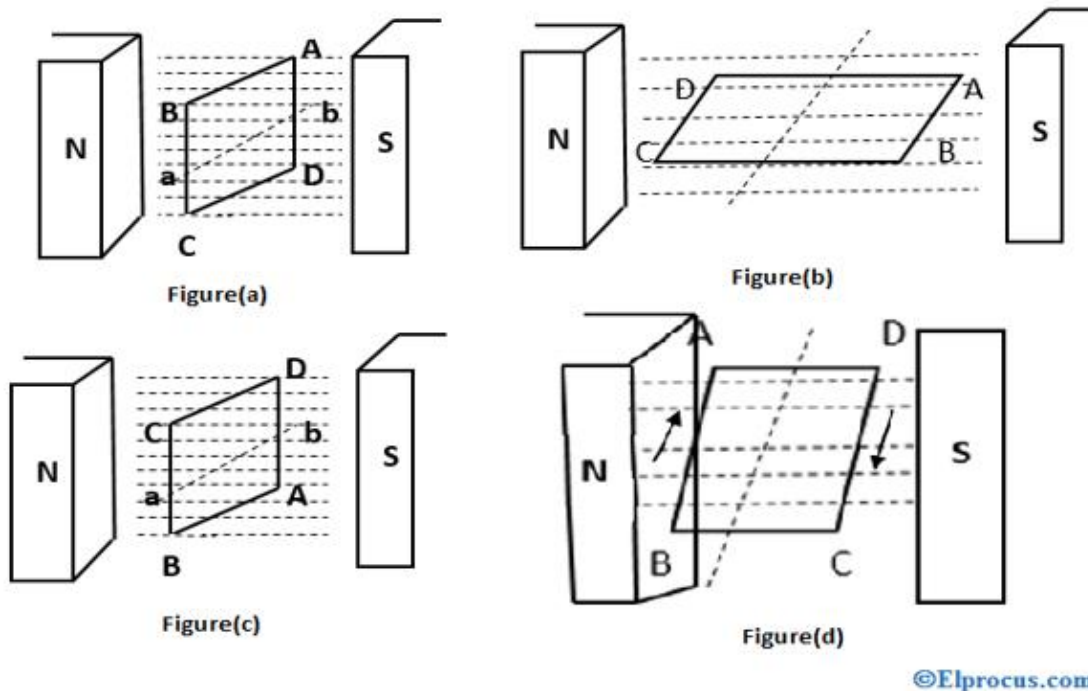

©Elprocus.com

1. If the rectangular coil rotates in a clockwise direction at an axis a and b, the conductor side A and B comes in front of the south pole and C and D come in front of a north pole as shown in figure (b). So, now we can say that the motion of the conductor is perpendicular to the flux lines from N to S pole and the conductor cuts the magnetic flux. At this position, the rate of flux cutting by the conductor is maximum because the conductor and flux are perpendicular to each other and therefore the current is induced in the conductor and this current will be in maximum position.
2. The conductor rotates one more time at 90° in a clockwise direction then the rectangular coil comes in the vertical position. Now the position of the conductor and magnetic flux line is parallel to each other as shown in figure (c). In this figure, no flux is cutting by the conductor and therefore no current is induced. In this position, the waveform is reduced to zero degrees because the flux is not cutting.
3. In the second half cycle, the conductor is continued to rotate in a clockwise direction for another 90°. So here the rectangular coil comes to a horizontal position in such a way that the conductor A and B comes in front of the north pole, C and D come in front of the south pole as shown in the figure (d). Again the current will flow through the conductor that is currently induced in the conductor A and B is from point B to A and in conductor C and D is from point D to C, so the waveform produced in opposite direction, and



reaches to the maximum value. Then the direction of the current indicated as A, D, C and B as shown in figure (d). If the rectangular coil again rotates in another 90° then the coil reaches the same position from where the rotation is started. Therefore, the current will again drop to zero.

4. In the complete cycle, the current in the conductor reaches the maximum and reduces to zero and in the opposite direction, the conductor reaches the maximum and again reaches zero. This cycle repeats again and again, due to this repetition of the cycle the current will be induced in the conductor continuously.

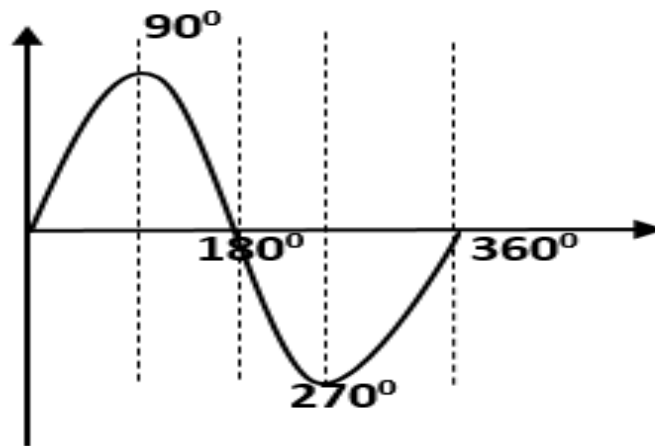

©Elprocus.com

This is the process of producing the current and EMF of a single-phase. Now for producing 3 phases, the coils are placed at the displacement of 120° each. So the process of producing the current is the same as the single-phase but only the difference is the displacement between three phases is 120°. This is the working principle of an alternator.

### **Applications**

The applications of an alternator are

- Automobiles
- Electrical power generator plants
- Marine applications
- Diesel electrical multiple units
- Radiofrequency transmission

### **Advantages**

The advantages of an alternator are

- Cheap

- Low weight
- Low maintenance
- Construction is simple
- Robust
- More compact

### Disadvantages

The disadvantages of an alternator are

- Alternators need transformers
- Alternators will overheat if the current is high

### Construction of Synchronous generator or alternator:

In **Synchronous generator** or alternator the stationary winding is called 'stator' while the rotating winding is called 'Rotor'.

#### Stator:

The stator in the synchronous generator is a stationary armature. This consists of a core and the slots to hold the armature winding similar to the armature of a d.c generator. The stator core uses a laminated construction. It is built up of special steel stampings insulated from each other with varnish or paper. The laminated construction is basically to keep down eddy current losses.

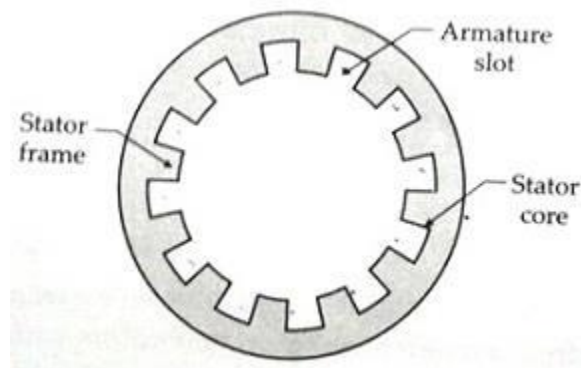

Generally choice of material is steel to keep down hysteresis losses. The entire core is fabricated in a frame made of steel plates. The core has slots on its periphery for housing the armature conductors. The frame does not carry any flux and serves as the support to the core. Ventilation is maintained with the help of holes cast in the frame.

#### Rotor:

There are two types of rotors used in the synchronous generators or alternators:

- 1) **Salient pole rotor**
- 2) **Smooth cylindrical rotor**

### 1) Salient pole rotor:

This is also called projected pole type as all the poles are projected out from the surface of the rotor. The poles are built up of thick steel laminations. The poles are bolted to the rotor as shown in the figure. The pole face has been given a specific shape. The field winding is provided on the pole shoe. These rotors have large diameters and small axial lengths.

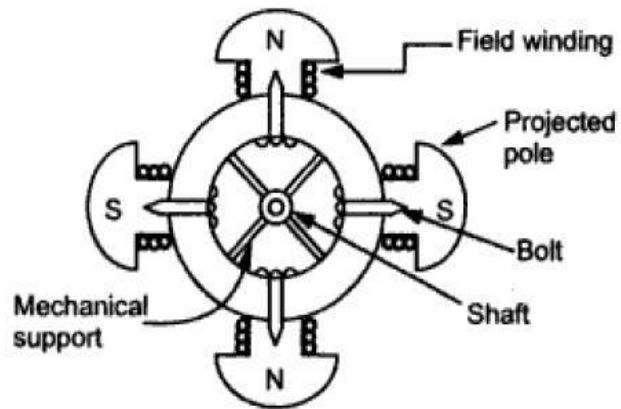
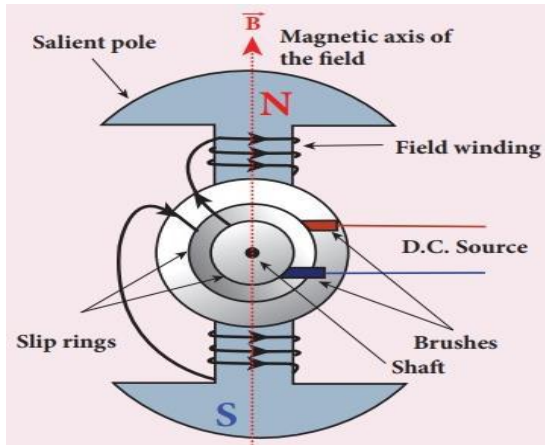

The limiting factor for the size of the rotor is the centrifugal force acting on the rotating member of the machine. As the mechanical strength of salient pole type is less, this is preferred for low-speed alternators ranging from 125 r.p.m to 50 r.p.m. The prime movers used to drive such rotor are generally water turbines and I.C. engines.

### 2) Smooth cylindrical rotor:

This is also called **non-salient** type or **non-projected pole type** or round rotor. This rotor consists of a smooth solid steel cylinder, having a number of slots to accommodate the field coil. These slots are covered at the top with the help of steel or manganese wedges. The unslotted portions of the cylinder itself act as the poles. The poles are not projecting out and the surface of the rotor is smooth which maintains a uniform air gap between stator and rotor.

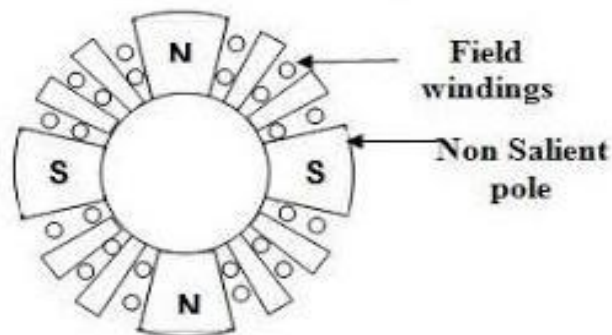

These rotors have small diameters and large axial lengths. This is to keep peripheral speed within limits. The main advantage of this type is that these are mechanically very strong and thus preferred for high-speed **alternators** ranging between 1500 to 3000 r.p.m. Such high-speed alternators are called 'turbo-alternators'. The prime movers used to drive such type of rotors are generally steam turbines, electric motors.

### Induced emf equation of a 3- $\phi$ Alternator:-

Let

$\phi$  = flux per pole (cub)

N = rotor speed (rpm)

F = frequency of induced emf (Hz)

P = no. of poles

Z = no. of conductors/coil sides in series / phase

= 2T

T = no. of turns [one turn = 2coil sides (or) conductors]

$K_d$  = distribution factor =  $\frac{\sin \frac{m\beta}{2}}{m \sin \frac{\beta}{2}}$

$K_p$  = Pitch factor =  $\cos \frac{\alpha}{2}$

$K_f$  = form factor = 1.11 for sinusoidal

For one revolution of the rotor it takes a time of  $\frac{60}{N}$  sec

Each stator conductor cut by flux of ' $\phi$ '.

$$\therefore \text{change in flux / pole} = d\phi = \phi p$$

$$\text{Change in time} = dt = \frac{60}{N}$$

$$\therefore \frac{d\phi}{dt} = \frac{\phi p}{60/N} = \frac{\phi NP}{60} = \text{Average induced emf / conductor} \rightarrow 1$$

$$\text{Now, we know that } f = \frac{PN}{120} \Rightarrow N = \frac{120 f}{P} \rightarrow 2$$

2 in 1 as

$$\text{Avg. emf per conductor} = \frac{\phi NP}{60}$$

$$= \frac{\phi NP}{60} \cdot \frac{120 f}{P}$$

$$= 2\phi f \text{ (volts)}$$

If there are 'z' conductors in series / phase,

$$\text{Then average induced emf/conductor} = 2\phi fz = 2\phi f(2T) = 4\phi fT$$

We know,

$$\text{Form factor} = K_f = \frac{\text{avg}}{\text{rms}} = 1.11$$

Then,

$$\text{RMS value of emf/ph} = 1.11 \times \text{avg.}$$

$$= 1.11 \times 4\phi fT$$

$$E_g(\text{rms}) = 4.44\phi fT \text{ volts.}$$

But the above equation is not being so, the actual available voltage is reduced in the ratio of two factors i.e.,  $K_p$  and  $K_d$ .

$$\therefore \text{Actual available voltage/ph} = 4.44 K_p K_d \phi fT \text{ (volts)}$$

If alternator is star connected, then emf is  $\sqrt{3}$  times of phase emf.

### Winding factor:-

It is the product of the distribution and pitch factors.

$$\text{i.e., } K_w = K_p \times K_d$$

It is denoted by ' $K_w$ '

## **ARMATURE REACTION OF ALTERNATOR:**

The effect of **armature (stator) flux on the flux produced by the rotor field poles** is called armature reaction.

The effect of armature reaction depends on the power factor i.e the phase relationship between the terminal voltage and armature current.

When there is no load connected to an alternator or synchronous generator there will be no induced voltage in the armature. Hence, the flux present in the air-gap is only due to field ampere-turns. Once an alternator is loaded it starts supplying the load current and there will be an induced voltage in the armature windings. Since, the induced voltage is of three-phase, the armature current setups its own rotating magnetic field. Now there will be two magnetic fluxes in the air-gap of the machine setup be field and armature winding.

The flux produced by the armature winding is in such a way that either it opposes or add-up with the field flux causing decrease or increase in the air-gap flux. This causes a change in the performance of the machine. The nature of the effect of armature flux on the field flux depends upon the nature of the power factor of the load. Let us see the effect of armature reaction at different power factor loads.

Consider an individual armature coil moving towards the right relative to the field system. Each coil side has the maximum emf induced in it when it is opposite to a pole center.

### **Armature Reaction of Alternator at Unity Power Factor :**

Consider an alternator is supplying to a purely resistive load. The current is in phase with the voltage i.e., unity power factor, and therefore the position of the coil for maximum current will be the same as the position for maximum voltage. The armature current produces armature flux lags behind the main flux by  $90^\circ$  and it magnetizes the trailing half of the main pole and demagnetizes the leading half. However, these two effects neutralize each other and average field strength remains the same. The net effect is that the main field is distorted as shown below.

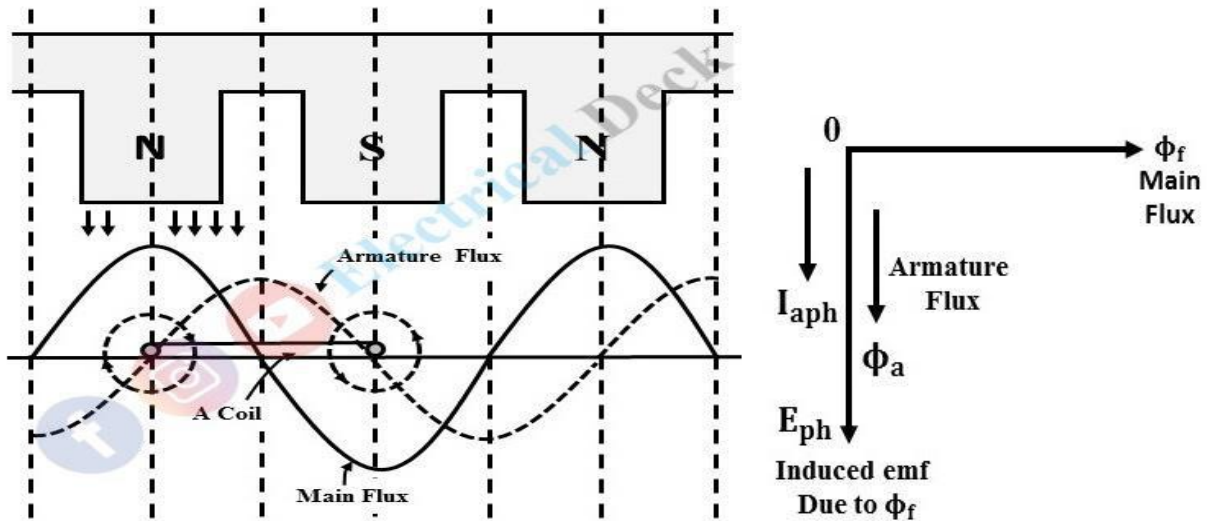

The below shows the phasor diagram at unity power factor load with a phase difference of  $90^\circ$  between the field flux and armature winding flux. The effect on the alternator due to the armature reaction for unity power factor load causes a small terminal voltage drop of an alternator. The effect of armature reaction under unity power factor load is called the 'Cross Magnetising Effect' of armature reaction.

#### Armature Reaction of Alternator at Zero Power Factor Lagging :

When the load is purely inductive the current lags  $90^\circ$  behind the voltage, and therefore, the coil has to advance  $90^\circ$  ( electrical ) from the earlier position as shown in the below figure. Hence armature flux lags behind the main flux by a pole.

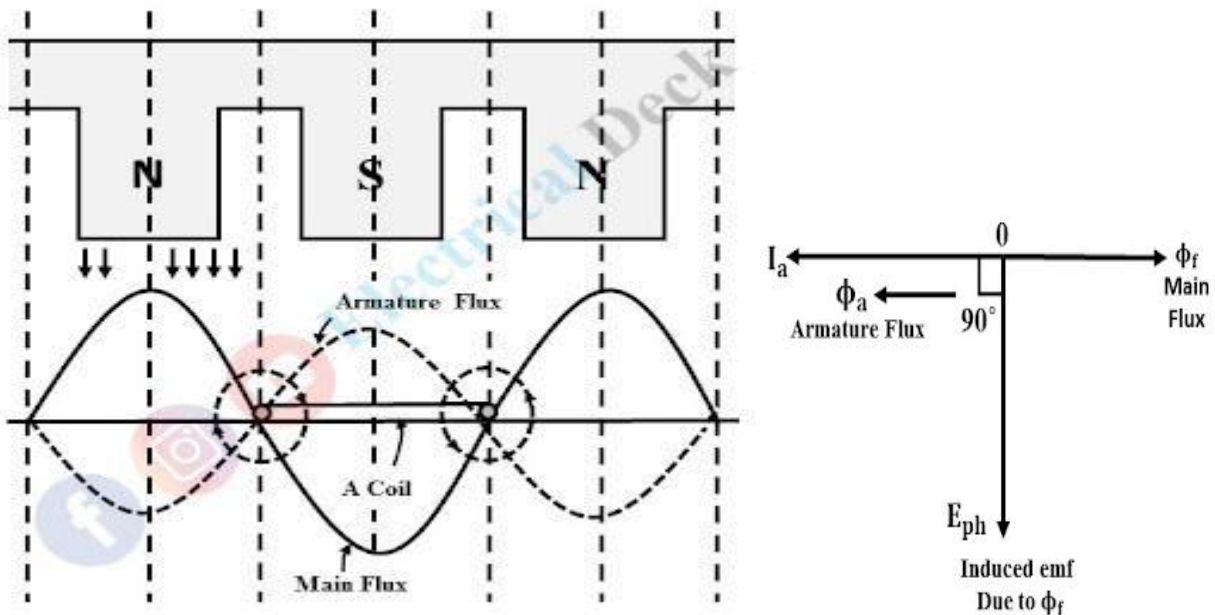

From the phasor diagram, it is seen that the fluxes due to armature winding and main field winding are completely in opposite direction. Comparing the armature and main fluxes, we see that with an inductive load the effect of armature reaction reduces the main flux. This results in less emf in generation due to the weakening of main flux. To keep up the same emf, field excitation has to be increased to compensate weakening effect. Since the effect of armature reaction due to inductive load causes demagnetizing of main field flux. The effect is called as 'Demagnetising Effect' of armature reaction.

### Armature Reaction of Alternator at Zero Power Factor Leading :

In this case, the current leads the voltage by  $90^\circ$ . so that the coil carries its maximum current by  $90^\circ$  before it reaches the position as shown below.

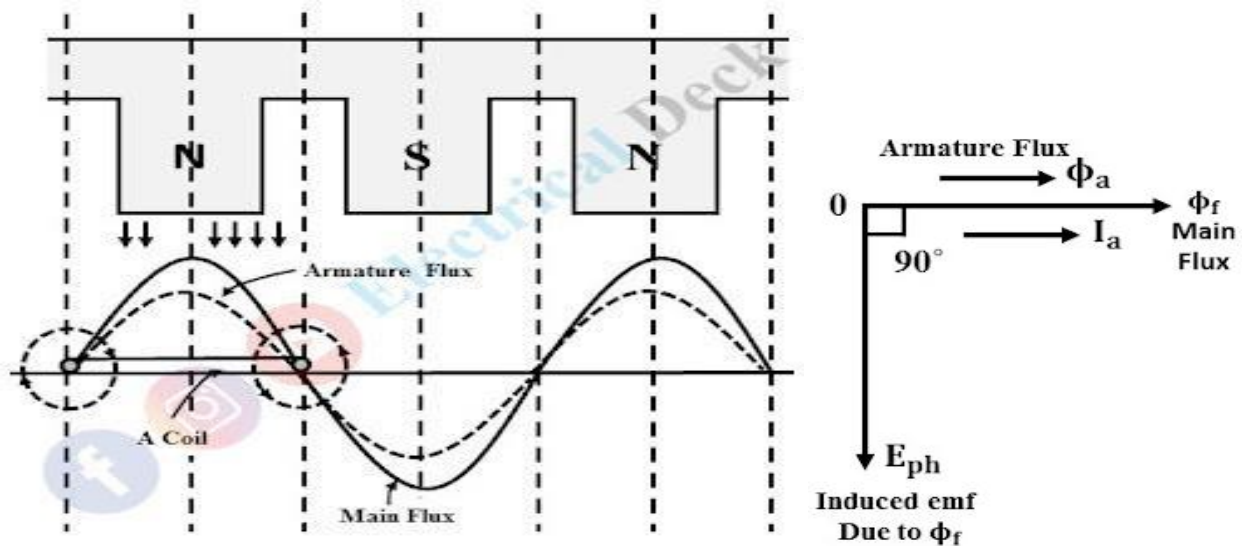

When the load connected to the alternator is of purely capacitive type. The armature current due to emf induced by main field flux leads by  $90^\circ$  as shown in the below phasor diagram. Thus the armature winding flux and main field flux will be in the same direction and add-up each other. Hence, in this case, the armature reaction exerts a wholly magnetizing effect due to the addition of both fluxes. This results in greater induced emf, and the terminal voltage of the alternator. To keep up the same emf the excitation to the field has to be reduced. Since the armature flux assists field flux, therefore the effect is called as 'Magnetising effect' of armature reaction.



## Nature of Armature Reaction :

The effect of armature reaction on the terminal voltage generated by alternator at various power factor loads is shown in the below figure.

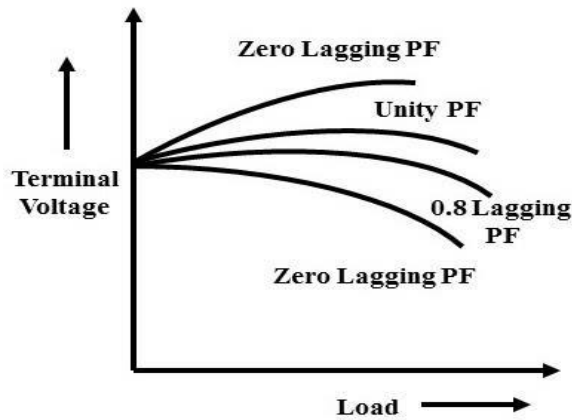

At unity power factor i.e., when a load is of purely resistive type, there will be a small change in the terminal voltage compared to inductive and capacitive loads.

Generally, most of the loads on an alternator is resistive-inductive type. When a load is disconnected suddenly from the transmission line connected to the alternator this causes capacitive loading on the alternator. If there are no proper preventive measures incorporated, the capacitive loading rises the terminal voltage and may create a desperate situation for the alternator.

Therefore, the change in terminal voltage due to the armature reaction effect at zero lagging and leading power factor is more.

Also, in addition to the armature reaction, there will be a voltage drop due to winding resistance and leakage reactance. Therefore, the total voltage drop in an alternator when it is loaded is the combination of drops due to winding resistance, leakage reactance, and armature reaction effect.

The induced emf in the alternator has to supply the above drops while supplying the load.

Therefore the equation for terminal voltage of an alternator is given as,

$$E_{ph} = V_{ph} + I_a R_a + I_a X_s \text{ volt}$$

From the above voltage equation, let us draw the phasor diagram of a synchronous generator operating at different load power factors. The relation between terminal voltage and current for power factor analysis can be done by the phasor diagram.

Let,

$E_{ph}$  = Induced emf on load per phase.

$V_{ph}$  = Terminal voltage per phase

$I_a$  = Armature current

$\phi$  = Phase angle between  $I_a$  and  $V_{ph}$  (i.e., p.f.)

$R_a$  = Armature resistance per phase

$X_s$  = Synchronous reactance ( leakage reactance + armature reaction reactance )

Taking  $V_{ph}$  as the reference phasor. The phase relationship between armature induced emf  $E$  due to field flux  $\phi_f$  and the current flowing through the armature  $I_a$  depends upon the power factor of the load.

### Phasor Diagram at Unity Power Factor Load :

When the alternator is driving a unity power factor load ( resistive ) i.e.,  $\cos \phi = 1$ . The armature current  $I_a$  will be in phase with  $V_{ph}$  as shown below.

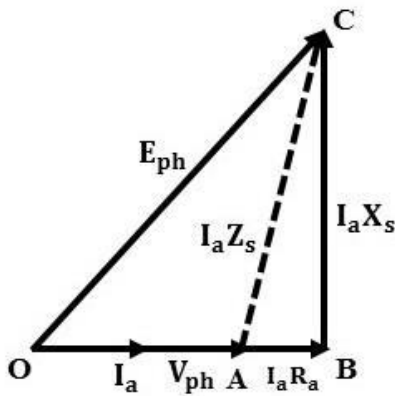

From the triangle OBC, the expression for induced emf  $E_{ph}$  is given as,

$$OC^2 = OB^2 + BC^2$$

$$E_{ph}^2 = (OA + AB)^2 + BC^2$$

At unity power factor  $\cos \phi = 1$  and  $\sin \phi = 0$ . The equation is modified as,

$$E_{ph} = \sqrt{(V_{ph} + I_a R_a)^2 + (I_a X_s)^2}$$

### Phasor Diagram at Lagging Power Factor Load :

For lagging power factor loads the current  $I_a$  will lag the terminal voltage  $V_{ph}$  with an angle  $\phi$ . At zero lagging power factor ( pure inductive ) the current  $I_a$  lags the voltage  $V_{ph}$  exactly by  $90^\circ$ .

The below shows the phasor diagram for the lagging power factor.

The armature resistance drop  $I_a R_a$  is due to armature current  $I_a$ . Hence it always lies in phase with current  $I_a$  i.e., DE. Therefore, from the triangle OCE,

**Phasor Diagram of a loaded Alternator Lagging PF Load**  
**Voltage Equation of Alternator,  $E_{ph} = V_{ph} + I_a R_a + j I_a X_s$**   
 (1) (2) (3)

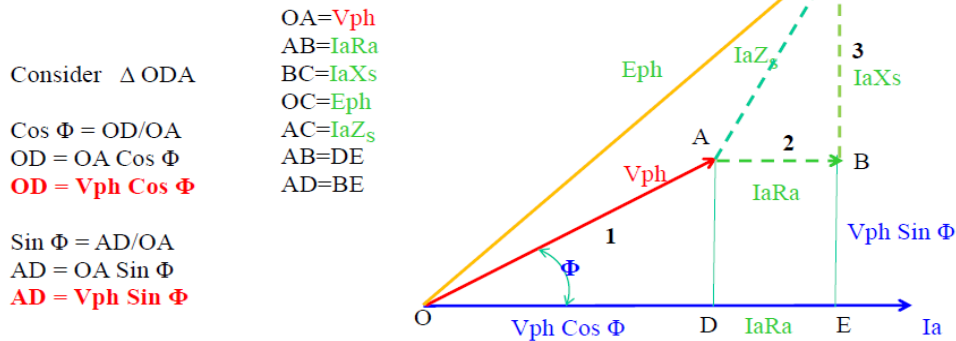

Consider  $\Delta OEC$

$(OC)^2 = (OE)^2 + (EC)^2$   
 $(E_{ph})^2 = (OD + DE)^2 + (EB + BC)^2$   
 $(E_{ph})^2 = (V_{ph} \cos \Phi + I_a R_a)^2 + (V_{ph} \sin \Phi + I_a X_s)^2$

$$E_{ph} = \sqrt{(V_{ph} \cos \Phi + I_a R_a)^2 + (V_{ph} \sin \Phi + I_a X_s)^2}$$

Phasor Diagram at Leading Power Factor Load :

Similar to the lagging power factor the current  $I_a$  leads the voltage  $V_{ph}$  by  $\phi$  at leading power factor loads as shown below. At zero leading power factor ( pure capacitive ) current  $I_a$  lead  $V_{ph}$  exactly by  $90^\circ$ .

**Phasor Diagram of a loaded Alternator : Leading PF Load**

Voltage Equation of Alternator,  $E_{ph} = V_{ph} + I_a R_a + j I_a X_s$

(1) (2) (3)

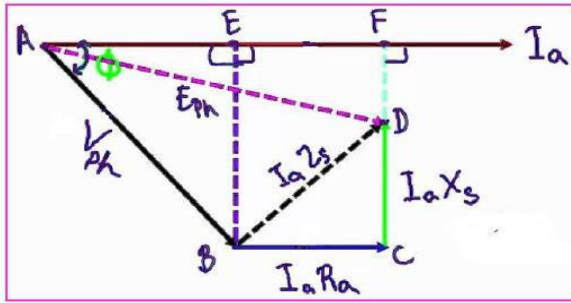

$$\begin{aligned} AB &= V_{ph} \\ BC &= I_a R_a = EF \\ CD &= I_a X_s \\ BD &= I_a Z_s \\ AD &= E_{ph} \end{aligned}$$

$\begin{aligned} \Delta ABE, \\ AE &= V_{ph} \cos \phi \\ CF = BE &= V_{ph} \sin \phi \\ BE &= CF \end{aligned}$	$\begin{aligned} \text{For } \Delta ADF \text{ use Pythagorean} \\ AD^2 &= AF^2 + DF^2 \\ \Rightarrow (E_{ph})^2 &= (AE + EF)^2 + (CF - CD)^2 \\ \Rightarrow (E_{ph})^2 &= (V_{ph} \cos \phi + I_a R_a)^2 + (V_{ph} \sin \phi - I_a X_s)^2 \\ \Rightarrow (E_{ph}) &= \sqrt{(V_{ph} \cos \phi + I_a R_a)^2 + (V_{ph} \sin \phi - I_a X_s)^2} \end{aligned}$
--	---

From triangle OCE,

$$OC^2 = OE^2 + EC^2$$

$$E_{ph}^2 = (OD + DE)^2 + (BE - BC)^2$$

$$E_{ph} = \sqrt{(V_{ph} \cos \phi + I_a R_a)^2 + (V_{ph} \sin \phi - I_a X_s)^2}$$

From the above, we can conclude that,

- For unity and lagging p.f. the sign of  $I_a X_s$  will be positive. Because the armature reaction effect in  $X_s$  will be demagnetizing and cross-magnetizing effect at unity and lagging power factor.
- For leading p.f. the sign of  $I_a X_s$  will be negative. Thus  $V_{ph}$  is more than  $E_{ph}$  due to the magnetizing effect of armature reaction.

$$Z_s = R_a + jX_s \dots \dots (7)$$

The impedance  $Z_s$  in the above equation (7) is the **Synchronous Impedance**, and  $X_s$  is the **Synchronous Reactance**.

## Load Characteristics of Synchronous Generator:

While the exciting current and the speed remain constant, the terminal voltage changes with the load current in the armature and the relationship between the terminal voltage and load current of an alternator is known as its load characteristics.

When the armature current increases, the terminal voltage drops. This is mainly due to  
 (a) Resistance and reactance of armature winding, and  
 (b) Armature reaction.

The load characteristics of an alternator is shown in the figure.

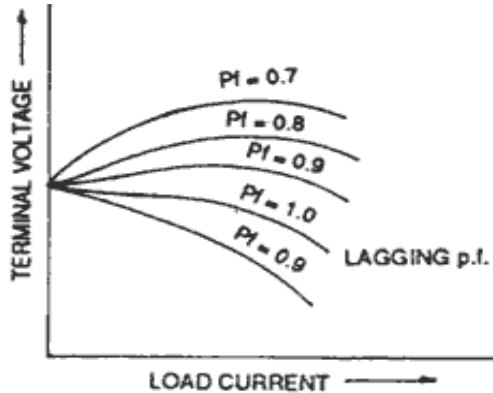

## EQUIVALENT CIRCUIT OF AN ALTERNATOR

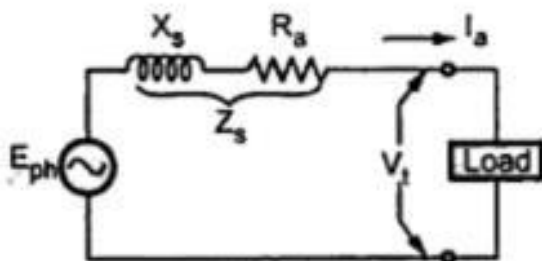

Thus in the equivalent circuit shown,

$E_{ph}$  = induced e.m.f. per phase on no load

$V_{tph}$  = terminal voltage per phase on load

$I_{aph}$  = armature resistance per phase

$Z_s$  = synchronous impedance per phase

and

$$\bar{E}_{ph} = \bar{V}_{tph} + \bar{I}_a \bar{Z}_s \dots \text{(Phasor sum)}$$

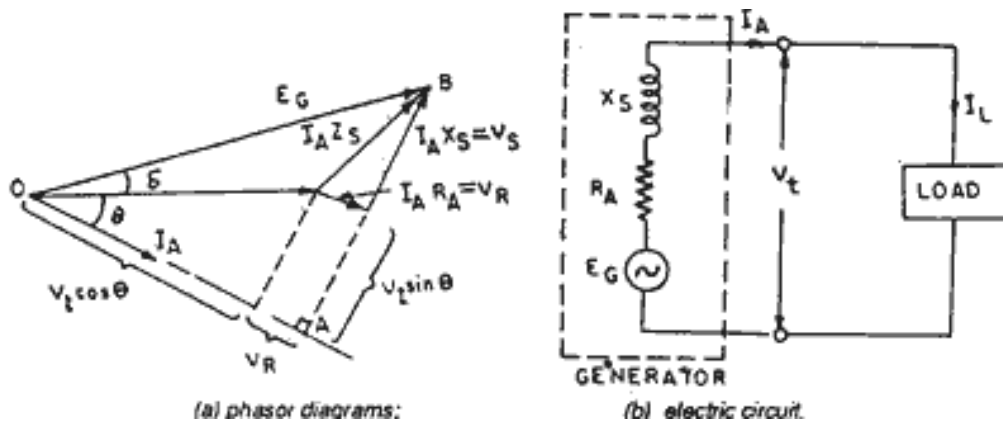

## REGULATION OF SYNCHRONOUS GENERATOR

The voltage regulation of an alternator is defined as the change in its terminal voltage when full load is removed, keeping field excitation and speed constant, divided by the rated terminal voltage.

- The value of the regulation not only depends on the load current but also on the power factor of the load.
- For lagging and unity p.f. conditions there is always drop in the terminal voltage hence regulation values are always positive.
- While for leading capacitive load conditions, the terminal voltage increases as load current increases. Hence regulation is negative in such cases.
- The relationship between load current and the terminal voltage is called load characteristics of an alternator.

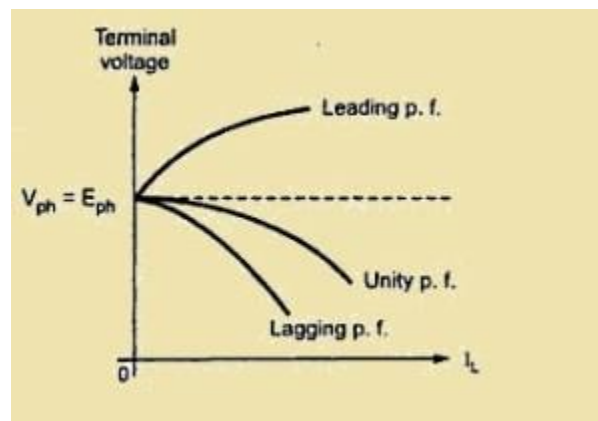

## Determination of Voltage Regulation

### ➤ In the case of small machines, the regulation may be found by direct loading.

- The alternator is driven at synchronous speed and the terminal voltage is adjusted to its rated value  $V$ .
- The load is varied until the wattmeter and ammeter (connected for the purpose) indicate the rated values at desired p.f. Then the entire load is thrown off while the speed and field excitation are kept constant.
- The open-circuit or no-load voltage  $E_0$  is read.

$$\text{Percentage Voltage Regulation} = \left( \frac{|E_0| - |V|}{|V|} \right)$$

$V$  = Rated terminal voltage,  $E_0$  = No load induced e.m.f.

### ➤ In the case of large machines, the cost of finding the regulation by direct loading becomes prohibitive.

- Hence, other indirect methods are used as discussed below.

## Methods of determining voltage regulation

1. Synchronous Impedance method or E.M.F method
2. The Ampere-turn or M.M.F. Method.
3. Zero Power Factor or Potier Method.
4. A.S.A. method

## 1. SYNCHRONOUS IMPEDANCE METHOD OR E.M.F METHOD

Generally, we use this Synchronous Impedance Method for high-speed or synchronous generator. This method is also known as EMF method. The Synchronous Impedance Method or Emf Method is based on the concept of replacing the effect of armature reaction by an imaginary reactance. The method requires following data to calculate the regulation. Before calculating the voltage regulation we need to calculate the following data.

**1. Armature Resistance per phase [ $R_a$ ]**

**2. Open Circuit characteristics which is a graph between open circuit voltage [ $V_{o.c.}$ ] and field current.**

**3. Short circuit characteristics which is a graph between short circuit current [ $I_{s.c.}$ ] and field current.**

## 1. Armature Resistance per phase

Armature Resistance per phase can be obtained by conducting stator resistance test on the alternator. It is done by connecting the dc voltage supply to the stator armature winding and the corresponding current is measured.

By doing so, the dc stator resistance is calculated and then by using the formula  $R_{ac} = 1.6 R_{dc}$  the ac stator resistance is determined.

## 2. Open Circuit Characteristics(OCC)

- Open circuit characteristics is obtained by conducting open circuit test in the Alternator. To do that, the connections are given as per the following circuit diagram.
- To perform this test, the stator windings are kept open.
- The Alternator was made to run at synchronous speed by adjusting the field rheostat of the dc motor.
- The field current of the alternator was varied in steps until the machine attains its maximum voltage. The corresponding readings were noted down.
- From the readings, a graph is drawn as below, where OCC represents the open circuit characteristics.

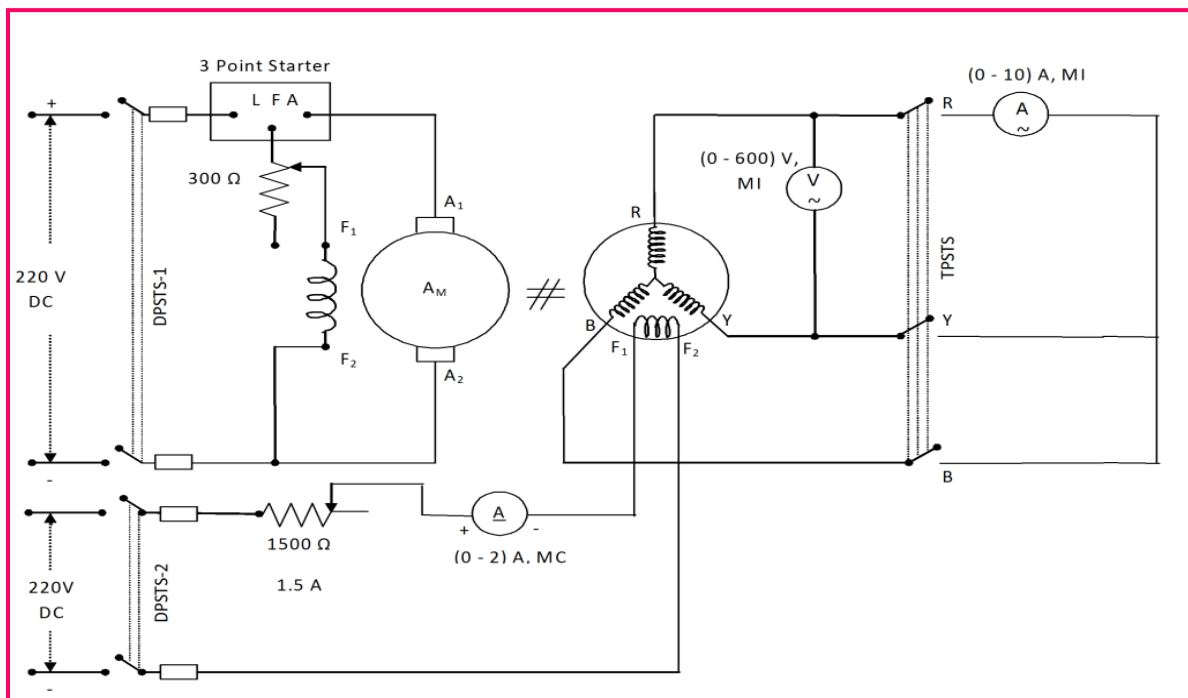



## *Experiment to determine the voltage regulation by EMF method*

### **3. Short Circuit Characteristics (SCC)**

- Short circuit characteristics is obtained by conducting short circuit test in the Alternator. To do that, the connections are given as per the above circuit diagram.
- The stator windings of alternator are Shorted and an ammeter is connected to measure the current flow.
- The Alternator was made to run at synchronous speed by adjusting the field rheostat of the dc motor.
- The field current of the Alternator was adjusted so that the armature current reaches its maximum rated value.
- Note the corresponding current readings and draw the graph. SCC in the graph below represents the short circuit characteristics.

#### **Determination of $Z_s$ from the graph**

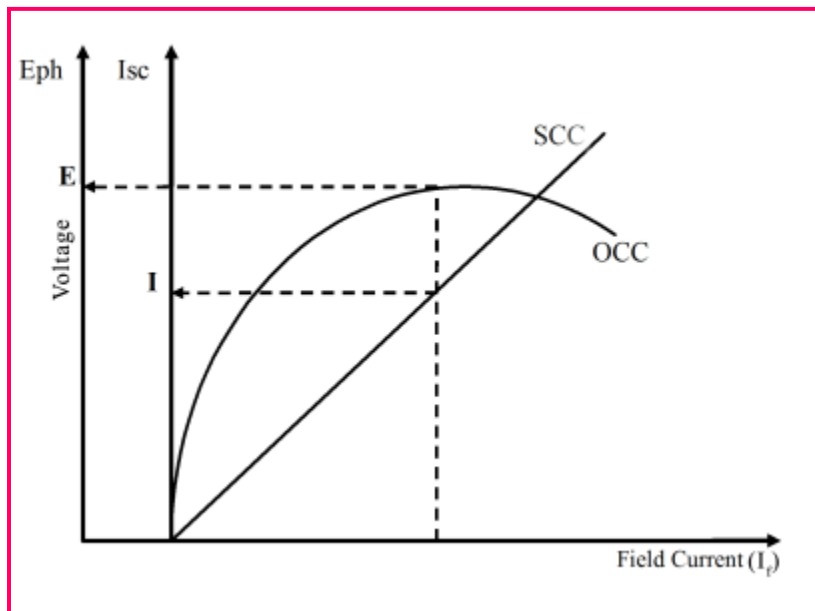

#### *Model Graph for determining the voltage regulation by EMF method*

The value of  $Z_s$  to be determined for the “**SAME VALUE OF FIELD EXCITATION**”.

Follow the simple procedure to draw the graph and obtain the voltage regulation.

1. Plot the OCC and SCC curve in a graph.
2. For the rated full load current ( $I_{sc}$ ) of alternator [which is to be found from the rating of alternator], draw a line that cuts the SCC curve, from that draw a vertical line towards the x-axis and find the field current( $I_f$ ).
3. For that field current, extend the line so that it cuts the OCC curve and find the open circuit voltage  $V_{oc}$  volts (phase value).
4. Now, we know the open circuit voltage  $V_{oc}$  volts and short circuit current  $I_{sc}$ . From this, determine the value of  $Z_s$  using the formula,

$$Z_s = \frac{V_{oc}}{I_{sc}}$$

5. From the known resistance value and determined  $Z_s$  found the value of  $X_s$  using the formula,

$$X_s = \sqrt{Z_s^2 - R_a^2}$$

6. Now, using the following formulas, obtain the value for  $E_{ph}$ , [obtained from phasor diagram]

For Lagging Power factor,

$$E_{ph} = \sqrt{(V_{ph} \cos\phi + I_a R_a)^2 + (V_{ph} \sin\phi + I_a X_s)^2}$$

For Leading Power factor,

$$E_{ph} = \sqrt{(V_{ph} \cos\phi + I_a R_a)^2 + (V_{ph} \sin\phi - I_a X_s)^2}$$

7. Finally the voltage regulation of alternator can be determined from the formula,

$$\text{Voltage Regulation} = \frac{E_{ph} - V_{ph}}{V_{ph}}$$

*Find voltage regulation at full load means, from given machine rating we have to find  $I_a$*

*There for  $I_a = I_{sc}$*

### **Advantages and Limitations of Synchronous Impedance Method:**

#### **Advantage:**

synchronous impedance  $Z_s$  for any load condition can be calculated. Hence regulation of the alternator at any load condition and load power factor can be determined.

#### **Limitations:**

The main limitation of this method is that the method gives large values of synchronous reactance. This leads to high values of percentage regulation than the actual results. Hence this method is called pessimistic method.

This is all about synchronous Impedance method for calculation voltage regulation of synchronous machine.

## **2. MMF METHOD (AMPERE TURNS METHOD)**

This method of determining the regulation of an alternator is also called Ampere-turn method or Rothert's M.M.F. method.

The method is based on the results of open circuit test and short circuit test on an alternator. For any synchronous generator i.e. alternator, it requires M.M.F. which is product of field current and turns of field winding for two separate purposes.

It must have an M.M.F. necessary to induce the rated terminal voltage on open circuit.

2. It must have an M.M.F. equal and opposite to that of armature reaction m.m.f.

In this method, drop due to leakage reactance is considered as drop due to additional armature reaction

#### **Data required for this method,**

- Armature resistance
- Open circuit characteristics
- Short circuit characteristics

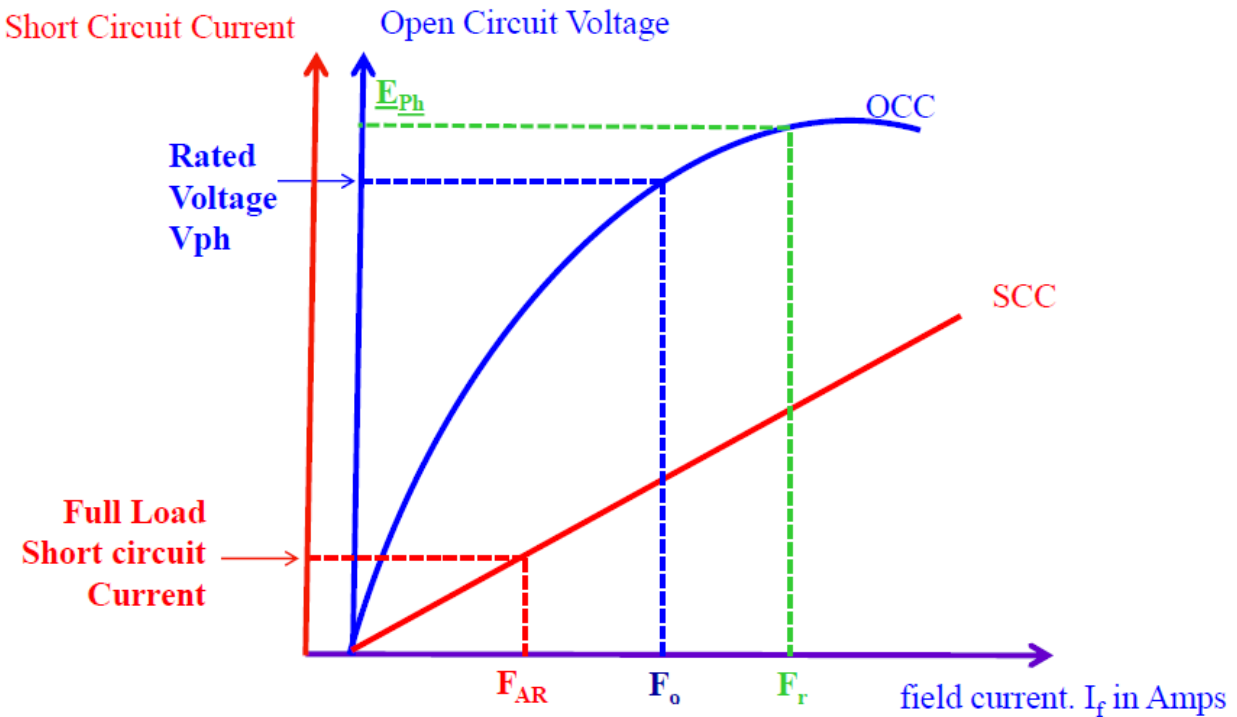

1. When the armature resistance is neglected
2. then  $F_o$  is to be calculated from OCC such that  $F_o$  represents the excitation (field current) required to produce a rated terminal voltage  $V_{ph}$  at output terminals
3. But if effective armature resistance  $R_{aph}$  is given
4. then  $F_o$  is to be calculated from OCC such that  $F_o$  represents the excitation (field current) required to produce a voltage of  $V_{ph} + I_{aph} R_a \cos \Phi$
5.  $F_{ar}$  is field mmf required to circulate full load current ( $I_L$  or  $I_{aph}$ ) is to be calculated from SCC
6.  $(F_r)^2 = (F_o)^2 + (F_{ar})^2 - 2 F_o F_{ar} \cos(\theta_o \wedge \theta_{ar})$
7.  $F_o \wedge F_{ar} = 90 + \Phi$  if  $\Phi$  is lagging       $F_o \wedge F_{ar} = 90 - \Phi$  if  $\Phi$  is leading
8. Once the  $F_r$  is known, obtain the corresponding induced emf  $E_{ph}$  required to get rated terminal voltage  $V_{ph}$  from OCC.

$$\% R = \frac{E_{ph} - V_{ph}}{V_{ph}} \times 100$$

### 3. ZERO POWER FACTOR (ZPF) FOR REGULATION OF ALTERNATOR

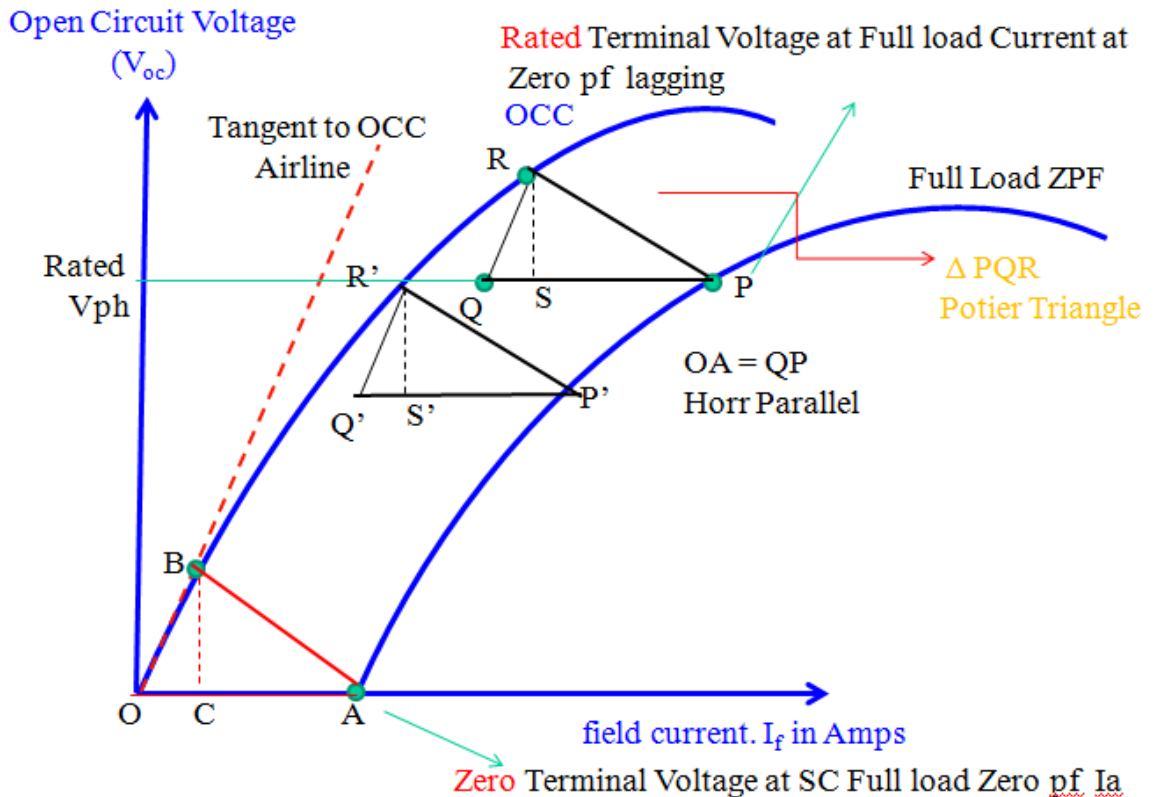

RS Voltage Drop Armature Leakage Reactance ( $I_a X_L$ )

PQ gives  $I_f$  necessary to overcome Demagnetizing Armature Reaction

SQ repre  $I_f$  required to induce an EMF balancing of leakage reactance (RS)

1. Plot open circuit characteristics on a graph paper as shown in the below figure.
2. Draw the tangent to O.C.C. through origin which is line OB as shown dotted in below figure. This is called the airline.
3. Plot ZPF Curve using two points:
  - a) Plot the excitation corresponding to zero terminal voltage i.e. short circuit full load zero power factor armature current. This point is shown as A on the x-axis.
  - b) Another point is the rated voltage when the alternator is delivering full current at zero p.f. lagging. This point is P as shown in the below figure.
4. On ZPF Curve from Point P, Draw the horizontal line PQ parallel and equal to OA.
5. From the point, Q draw the line parallel to the airline which intersects O.C.C. at point R. Join RQ and join PR. The triangle PQR is called Potier triangle.
6. From point R, drop a perpendicular on PQ to meet at point S.
7. The perpendicular RS gives the voltage drop due to the armature leakage reactance i.e.  $I_a X_L$

$$l(RS) = l(BC) = (I_{aph})_{F.L.} \times X_{Lph}$$

$$X_{Lph} = \frac{l(RS) \text{ or } l(BC)}{(I_{aph})_{F.L.}} \quad \Omega$$

8. The length PS gives field current necessary to overcome the demagnetising effect of armature reaction at full load.

9. The length SQ represents field current required to induce an EMF for balancing leakage reactance drop RS.

These values can be obtained from any Potier triangle such as OAB, PQR and so on.

10. Phasor sum of  $V_{ph}$  rated,  $I_{ph} R_{aph}$  and  $I_{ph} X_{Lph}$  gives the e.m.f. which is say  $E_{1ph}$ .

$$E_{1ph} = V_{ph} + I_{ph} R_{aph} + I_{ph} X_{Lph}$$

11. Obtain the excitation corresponding to  $E_{1ph}$  from OCC which is drawn. Let this excitation be  $F_{f1}$ . This is excitation required for inducing EMF which does not consider the effect of armature reaction

12. The field current required to balance armature reaction can be obtained from Potier triangle method, which is say  $F_{AR}$ .

$$F_{AR} = l(PS) = I(AC) \dots\dots$$

13. The total excitation  $F_r$  required is the vector sum of the  $F_{f1}$  and  $F_{AR}$ . This can be obtained exactly similar to the procedure used in MMF method.

$$(F_r)^2 = (F_{f1})^2 + (F_{ar})^2 - 2 F_{f1} F_{ar} \cos(F_{f1} \wedge F_{ar})$$

$$F_{f1} \wedge F_{ar} = 90 + \Phi \text{ if } \Phi \text{ is lagging} \quad F_{f1} \wedge F_{ar} = 90 - \Phi \text{ if } \Phi \text{ is leading}$$

14. Once the total excitation is known which is  $F_r$ , the corresponding induced emf  $E_{ph}$  can be obtained from OCC.

Once  $E_{ph}$  is known, the regulation of an alternator can be predicted as,

$$\% R = \frac{E_{ph} - V_{ph}}{V_{ph}} \times 100$$

**With the help of neat sketch, explain the two reaction theory of an synchronous machine.**

**BLONDEL TWO REACTION THEORY (THEORY OF SALIENT POLE MACHINE):**

It is known that in case of nonsalient pole type alternators the air gap is uniform. Due to uniform air gap, the field flux as well as armature flux vary sinusoidally in the air gap. In nonsalient rotor

alternators, air gap length is constant and reactance is also constant. Due to this the m.m.f.s of armature and field act upon the same magnetic circuit all the time hence can be added vectorially. But in salient pole type alternators the length of the air gap varies and the reluctance also varies. Hence the armature flux and field flux cannot vary sinusoidally in the air gap. The reluctances of the magnetic circuits on which m.m.f.s act are different in case of salient pole alternators.

Hence the armature and field m.m.f.s cannot be treated in a simple way as they can be in a nonsalient pole alternators.

The theory which gives the method of analysis of the distributing effects caused by salient pole construction is called two reaction theory. Professor Andre Blondel has put forward the two reaction theory.

**Note :** According to this theory the armature m.m.f. can be divided into two components as,

**1.Components acting along the pole axis called direct axis**

**2.Component acting at right angles to the pole axis called quadrature axis.**

The component acting along direct axis can be magnetising or demagnetising. The component acting along quadrature axis is cross magnetising. These components produces the effects of different kinds.

The Fig. 1 shows the stator m.m.f. wave and the flux distribution in the air gap along direct axis and quadrature axis of the pole.

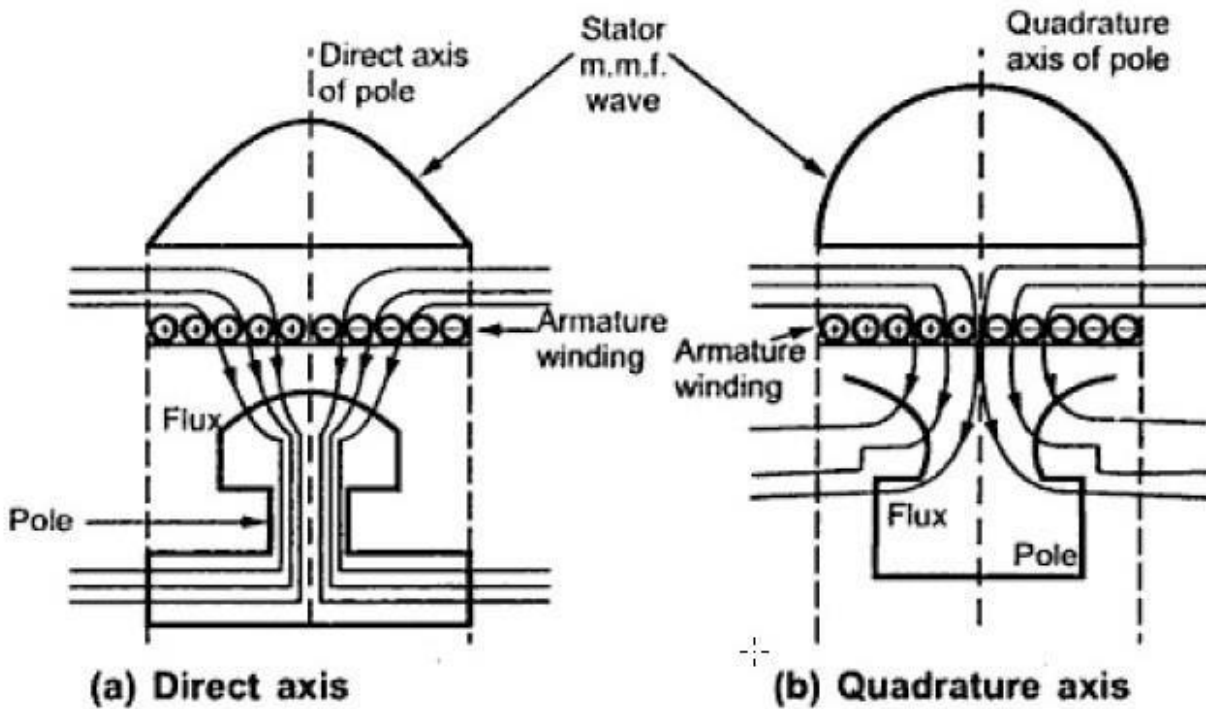

**Fig. 1 Flux distribution in air gap for salient pole machine**

The reluctance offered to the m.m.f. wave is lowest when it is aligned with the field pole axis. This axis is called direct axis of pole i.e. d-axis. The reluctance offered is highest when the m.m.f. wave is oriented at 90 to the field pole axis which is called quadrature axis i.e. q-axis. The air gap is least in the centre of the poles and progressively increases on moving away from the centre. Due to such shape of the pole-shoes, the field winding wound on salient poles produces the m.m.f. wave which is nearly sinusoidal and it always acts along the pole axis which is direct axis.

Let  $F_f$  be the m.m.f. wave produced by field winding, then it always acts along the direct axis. This m.m.f. is responsible to produce an excitation e.m.f.  $E_f$  which lags  $F_f$  by an angle  $90^\circ$ .

When armature carries current, it produces its own m.m.f. wave  $F_{AR}$ . This can be resolved in two components, one acting along d-axis (cross-magnetising). Similarly armature current  $I_a$  also can be divided into two components, one along direct axis and along quadrature axis. These components are denoted as,

$$F_d = \text{Component along direct axis}$$

$$F_{AR} : \}$$



$F_q =$  Component along quadrature axis

$I_d =$  Component along direct axis

$I_a : \}$

$I_q =$  Component along quadrature axis

The positions of  $F_{AR}$ ,  $F_d$  and  $F_q$  in space are shown in the Fig. 2. The instant chosen to show these positions is such that the current in phase R is maximum positive and is lagging  $E_f$  by angle  $\Psi$ .

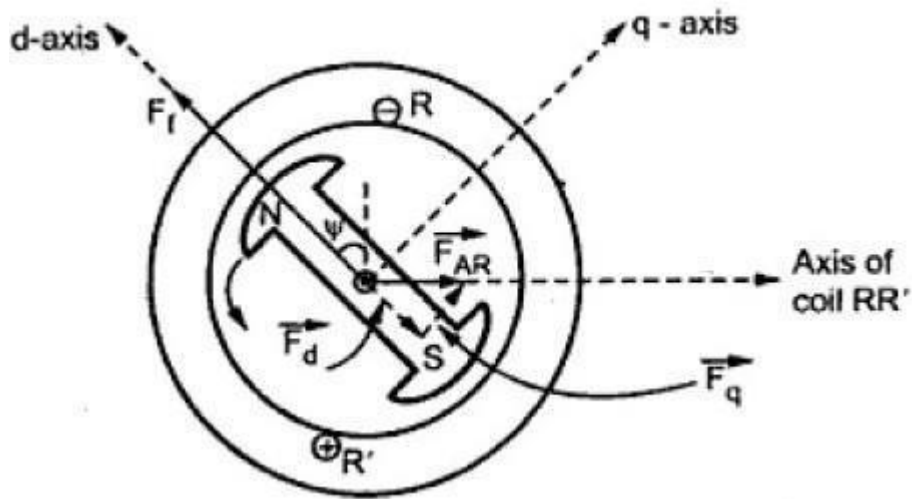

**Fig. 2 M.M.F. wave positions in salient pole machine**

The phasor diagram corresponding to the positions considered is shown in the Fig. 3. The  $I_a$  lags  $E_f$  by angle  $\Psi$ .

It can be observed that  $F_d$  is produced by  $I_d$  which is at  $90^\circ$  to  $E_f$  while  $F_q$  is produced by  $I_q$  which is in phase with  $E_f$ .

The flux components of  $\Phi_{AR}$  which are  $\Phi_d$  and  $\Phi_q$  along the direct and quadrature axis respectively are also shown in the Fig.3. It can be denoted that the reactance offered to flux along direct axis is less than the reactance offered to flux along quadrature axis. Due to this, the flux  $\Phi_{AR}$  is no longer along  $F_{AR}$  or  $I_a$ . Depending upon the reluctances offered along the direct and quadrature axis, the flux  $\Phi_{AR}$  lags behind  $I_a$ .



$$\therefore E_d = K_e \phi_d \angle -90^\circ = -j K_e \phi_d$$

and

$$E_q = K_e \phi_q \angle -90^\circ = -j K_e \phi_q$$

where  $K_e$  = e.m.f. constant of armature winding

The resultant e.m.f. is the phasor sum of  $E_f$ ,  $E_d$  and  $E_q$ .

$$\therefore \bar{E}_R = \bar{E}_f + \bar{E}_d + \bar{E}_q$$

$$= \bar{E}_f - j K_e \phi_d - j K_e \phi_q$$

Substituting expressions for  $\Phi_d$  and  $\Phi_q$

$$\therefore \bar{E}_R = \bar{E}_f - j K_e P_d K_{ar} \bar{I}_d - j K_e P_q K_{ar} \bar{I}_q$$

Now  $X_{ard}$  = Equivalent reactance corresponding to the d-axis component of armature reaction

$$= K_e P_d K_{ar}$$

and  $X_{arq}$  = Equivalent reactance corresponding to the q-axis component of armature reaction

$$= K_e P_q K_{ar}$$

$$\therefore \bar{E}_R = \bar{E}_f - j X_{ard} \bar{I}_d - j X_{arq} \bar{I}_q$$

For a realistic alternator we know that the voltage equation is,

$$\bar{E}_R = \bar{V}_t + \bar{I}_a R_a + X_L \bar{I}_a$$

where  $V_t$  = terminal voltage

$X_L$  = leakage reactance

But

$$\bar{I}_a = \bar{I}_d + \bar{I}_q$$

$$\therefore \bar{E}_R = \bar{V}_t + \bar{I}_a R_a + X_L \bar{I}_d + X_L \bar{I}_q$$

Substituting in expression for  $\bar{E}_R$ ,

$$\begin{aligned} \therefore \bar{V}_t + \bar{I}_a R_a + X_L \bar{I}_d + X_L \bar{I}_q &= \bar{E}_f - j X_{ard} \bar{I}_d - j X_{arq} \bar{I}_q \\ \therefore \bar{E}_f &= \bar{V}_t + \bar{I}_a R_a + j (X_L + X_{ard}) \bar{I}_d + j (X_L + X_{arq}) \bar{I}_q \\ \therefore \boxed{E_f} &= \bar{V}_t + \bar{I}_a R_a + j X_d \bar{I}_d + j X_q \bar{I}_q \end{aligned} \quad \dots(1)$$

where  $X_d =$  d-axis synchronous reactance  $= X_L + X_{ard}$  .....(2)

and  $X_q =$  q-axis synchronous reactance  $= X_L + X_{arq}$  .....(3)

It can be seen from the above equation that the terminal voltage  $V_t$  is nothing but the voltage left after deducing ohmic drop  $I_a R_a$ , the reactive drop  $I_d X_d$  in quadrature with  $I_d$  and the reactive drop  $I_q X_q$  in quadrature with  $I_d$ , from the total e.m.f.  $E_f$ .

The phasor diagram corresponding to the equation (1) can be shown as in the Fig. 1. The current  $I_a$  lags terminal voltage  $V_t$  by  $\Phi$ . Then add  $I_a R_a$  in phase with  $I_a$  to  $V_t$ . The drop  $I_d X_d$  leads  $I_d$  by  $90^\circ$  as in case purely reactive circuit current lags voltage by  $90^\circ$  i.e. voltage leads current by  $90^\circ$ . Similarly the drop  $I_q X_q$  leads  $X_q$  by  $90^\circ$ . The total e.m.f. is  $E_f$ .

In the phasor diagram shown in the Fig. 4, the angles  $\Psi$  and  $\delta$  are not known, through  $V_t$ ,  $I_a$  and  $\Phi$  values are known. Hence the location of  $E_f$  is also unknown. The components of  $I_a$ ,  $I_d$  and  $I_q$  can not be determined which are required to sketch the phasor diagram.

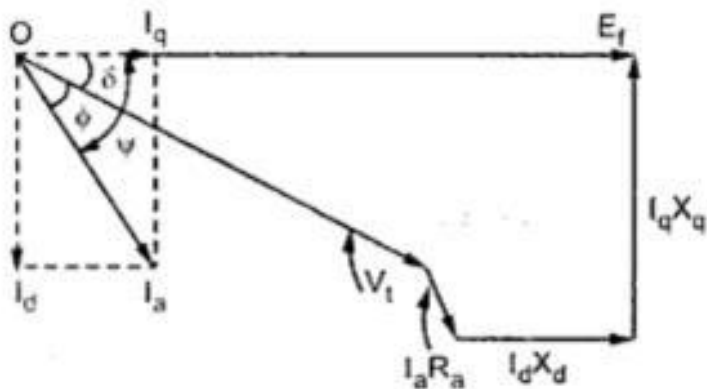

**Fig. 4**

Let us find out some geometrical relationships between the various quantities which are involved in the phasor diagram. For this, let us draw the phasor diagram including all the components in detail.

We know from the phasor diagram shown in the Fig. 4 that,

$$I_d = I_a \sin \Psi \quad \dots\dots\dots (4)$$

$$I_q = I_a \cos \Psi \quad \dots\dots\dots(5)$$

$$\cos \Psi = I_q / I_a \quad \dots\dots\dots(6)$$

The drop  $I_a R_a$  has two components which are,

$I_d R_d =$  drop due to  $R_a$  in phase with  $I_d$

$I_q R_a =$  drop due to  $R_a$  in phase with  $I_q$

The  $I_d X_d$  and  $I_q R_q$  can be drawn leading  $I_d$  and  $I_q$  by  $90^\circ$  respectively. The detail phasor diagram is shown in the Fig. 5.

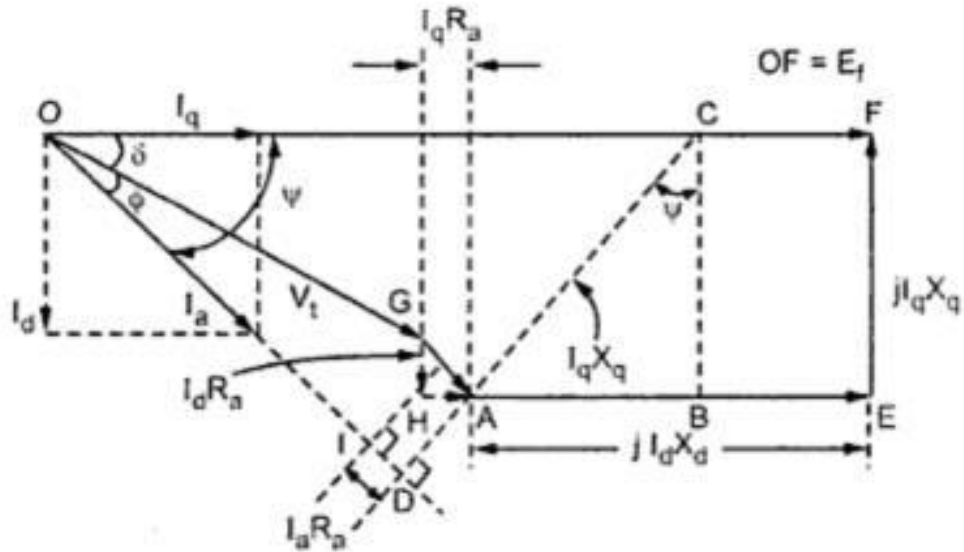

**Fig. 5 Phasor diagram for lagging p.f.**

In the phasor diagram,

$$OF = E_f$$

$$OG = V_t$$

$$GH = I_d R_a \text{ and } HA = I_q R_a$$

$$GA = I_a R_a$$

$$AE = I_d X_d \text{ and } EF = I_q X_a$$

Now DAC is drawn perpendicular to the current phasor  $I_a$  and CB is drawn perpendicular to AE.

The triangle ABC is right angle triangle,

$$\therefore \cos \psi = \frac{BC}{AC} = \frac{I_q X_q}{AC} \quad \dots\dots(7)$$

But from equations (6),  $\cos \Psi = I_q / I_a$

$$\therefore \frac{I_q}{I_a} = \frac{I_q X_q}{AC}$$

$$\therefore AC = I_a X_q \quad \dots(8)$$

Thus point C can be located. Hence the direction of  $E_f$  is also known.

Now triangle ODC is also right angle triangle,

$$\therefore \tan \psi = \frac{CD}{OD} \quad \dots (9)$$

Now  $OD = OI + ID = V_t \cos \Phi + I_a R_a$

and  $CD = AC + AD = I_a X_q + V_t \sin \Phi$

$$\therefore \boxed{\tan \psi = \frac{V_t \sin \phi + I_a X_q}{V_t \cos \phi + I_a R_a}} \quad \dots(10)$$

As  $I_a X_q$  is known, the angle  $\Psi$  can be calculated from equation (10). As  $\Phi$  is known we can write,

$\delta = \Psi - \Phi$  for lagging p.f.

$$\therefore \boxed{E_f = V_t \cos \delta + I_q R_a + I_d X_d} \quad \dots(11)$$

Hence magnitude of  $E_f$  can be obtained by using equation (11).

Note : In the above relations,  $\Phi$  is taken positive for lagging p.f. For leading p.f.,  $\Phi$  must be taken negative.

**Infinite Bus:** The bus whose voltage and frequency remains constant even after the variation in the load is known as the infinite bus. The alternators operating in parallel in a power system is the example of the infinite bus.

#### **Characteristics of Infinite bus:**

1. Infinite bus possess very large rotational inertia due to which it avoids any incoming machine to alter the speed. Hence frequency remains constant.
2. Infinite bus maintains constant terminal voltage because the incoming machines are of low ratings.
3. As the infinite bus system possess number of alternators connected in parallel, the synchronous impedance is small

#### **Operating Characteristics of an Alternator connected to Infinite bus:**

4. Real power supplied by the alternator to the infinite bus is controlled by governor settings
5. The infinite bus system controls the frequency and terminal voltage of an alternator
6. The reactive power supplied by the alternator to the infinite bus is controlled by field excitation of alternator.

### **PARALLEL OPERATION OF ALTERNATOR**

**Interconnection** of the electric power systems is essential from the economical point of view and also for reliable and **Parallel Operation**. Interconnection of AC power systems requires synchronous generators to operate in **parallel** with each other. In generating stations, two or more generators are connected in parallel. The alternators are located at different locations forming a **grid** connected system.

They are connected parallel by means of transformer and transmission lines. Under normal operating conditions all the generators and synchronous motors in an interconnected system operate in **synchronism** with each other. A machine has to be adjusted for optimum operating efficiency and greater reliability if the generators are connected in parallel.

As the load increases beyond the generated capacity of the connected units, additional generators are parallel to carry the load. Similarly, if the load demand decreases, one or more machines are taken off the line as per the requirement. It allows the units to operate at a higher efficiency.

#### **Reasons of Parallel Operation**

Alternators are operated in parallel for the following reasons:

- ✓ Several alternators can supply a bigger load than a single alternator.
- ✓ One or more alternators may shut down during the period of light loads. Thus, the remaining alternator operates at near or full load with greater efficiency.
- ✓ When one machine is taken out of service for its scheduled maintenance and inspection, the remaining machines maintain the continuity of the supply.
- ✓ If there is a breakdown of the generator, there is no interruption of the power supply.
- ✓ Number of machines can be added without disturbing the initial installation according to the requirement to fulfill the increasing future demand of the load.
- ✓ Parallel operation of the alternator, reduces the operating cost and the cost of energy generation.
- ✓ It ensures the greater security of supply and enables overall economic generation.

### **Condition for Parallel Operation of Alternator**

There are some conditions to be satisfied for parallel operation of the alternator. Before entering into that, we should understand some terms which are as follows.

The process of connecting two alternators or an alternator and an infinite bus bar system in parallel is known as synchronizing.

Running machine is the machine which carries the load.

Incoming machine is the alternator or machine which has to be connected in parallel with the system.

### **The conditions to be satisfied are**

- ✓ The phase sequence of the incoming machine voltage and the bus bar voltage should be identical.
- ✓ The RMS line voltage (terminal voltage) of the bus bar or already running machine and the incoming machine should be the same.
- ✓ The phase angle of the two systems should be equal.



- ✓ The frequency of the two terminal voltages (incoming machine and the bus bar) should be nearly the same. Large power transients will occur when frequencies are not nearly equal.

Departure from the above conditions will result in the formation of power surges and current. It also results in unwanted electro-mechanical oscillation of rotor which leads to the damage of equipment.

### **Advantages of Parallel Operating Alternators**

- When there is maintenance or an inspection, one machine can be taken out from service and the other alternators can keep up for the continuity of supply.
- Load supply can be increased.
- During light loads, more than one alternator can be shut down while the other will operate in nearly full load.
- High efficiency.
- The operating cost is reduced.
- Ensures the protection of supply and enables cost-effective generation.
- The generation cost is reduced.
- Breaking down of a generator does not cause any interruption in the supply.
- Reliability of the whole power system increases.

### **SYNCHRONIZATION OF ALTERNATOR**

The process of connecting two alternators or an alternator and an infinite bus bar system in parallel is known as synchronizing. Running machine is the machine which carries the load. Incoming machine is the alternator or machine which has to be connected in parallel with the system.

#### **Method of Synchronization of Alternator**

1. Three Dark Lamps Method
2. Two Bright and One Dark Lamp Method
3. Synchroscope Method

#### **1. Three Dark Lamps Method**

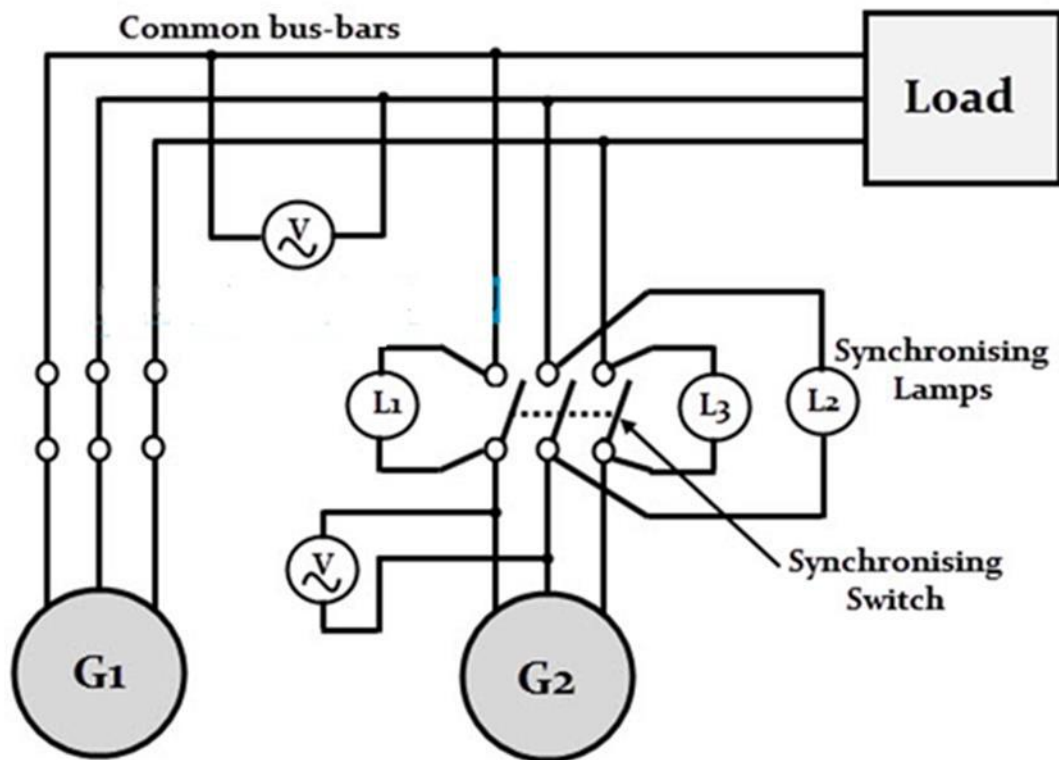

The figure above shows the circuit for bright lamp method used to synchronize the alternators. Assume that alternator is connected to the load supplying rated voltage and frequency to it. Now the alternator-2 is to be connected in parallel with alternator-1.

Three lamps (each of which is rated for alternator terminal voltage) are connected across the switches of the alternator-2. From the figure it is clear that the moment when all the conditions of parallel operation are satisfied, the lamps should be more or less dark.

1. To synchronize the alternator-2 with bus bar, the prime mover of the alternator-2 is driven at speed close to the synchronous speed decided by the bus bar frequency and number of poles of the alternator.
2. Now the field current of the generator-2 is increased till voltage across the machine terminals is equal to the bus bar voltage (by observing the readings on voltmeters).
3. If lamps glow ON and OFF concurrently, indicating that the phase sequence of alternator-2 matches with bus bar. On the other hand, if they ON and OFF one after another, it resembles the incorrect phase sequence.
4. If this is not the case, then this means phase sequences are not correct. In order to correct the phase sequence, two leads of the line of the incoming machine should be interchange.

5. The frequency of the incoming machine is adjusted until the lamps flicker at a very slow rate, less than one dark period per second. After finally adjusting the incoming voltage, the synchronizing switch is closed in the middle of their dark period.

### **Advantage of the dark lamp method**

1. the method is cheap
2. the proper phase sequence is easily determined

### **Disadvantages of the dark lamp method**

1. The lamps become dark at about half their rated voltage, it is possible that the synchronizing switch might be closed where there is a considerable phase difference between machines. This may result in high circulating current to damage the machines.
2. The lamps filament might burn out.
3. The flicker of the lamps does not indicate which machine has the higher frequency.

**Suppose, if the bus bar frequency is 50Hz, the rate of flickering of lamps is same when the frequency of the alternator is either 51 or 49 Hz, as the difference in these two cases is 1Hz.**

### **2. Two Bright and One Dark Lamp Method**

Consider an alternator B is to be synchronized. In this case lamp L1 is connected across R – R', lamp L2 is connected across Y – B' and lamp L3 is connected across B – Y' as shown in Figure.

### **Method of Synchronization of Alternator**

Here I am describing the 'two bright and one dark lamp method' of synchronization of alternators. This method is generally used in colleges to demonstrate this process to students.

Consider an alternator B is to be synchronized. In this case lamp L1 is connected across R – R', lamp L2 is connected across Y – B' and lamp L3 is connected across B – Y' as shown in Figure.

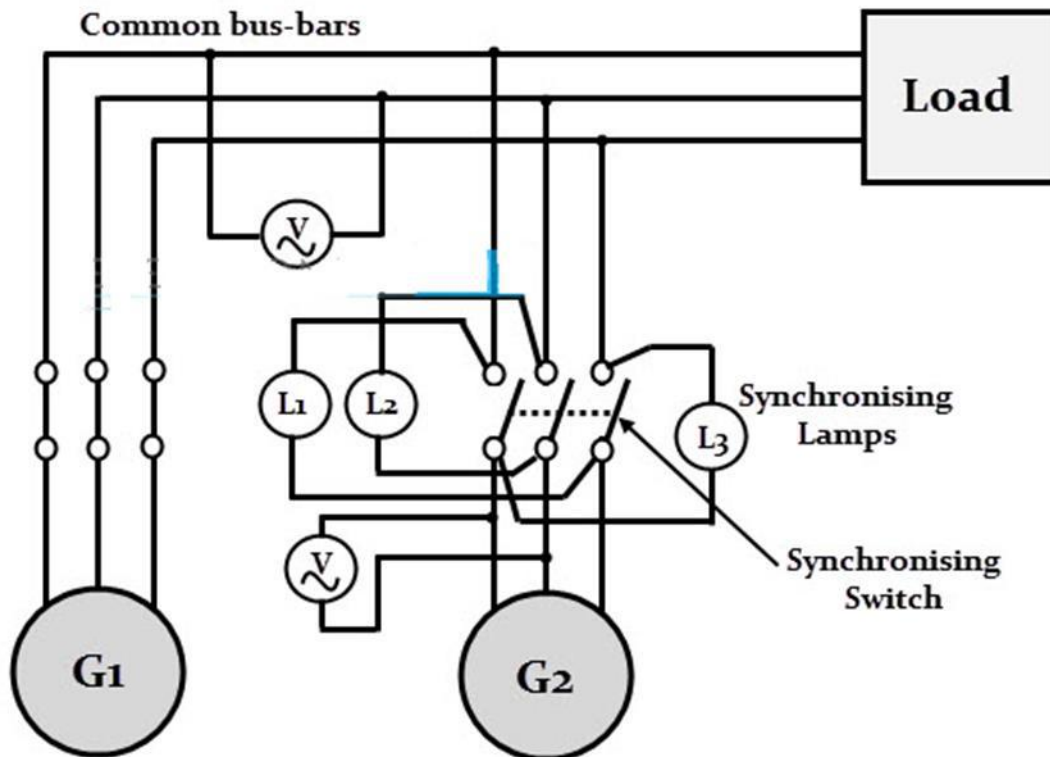

If the voltages are equal, the frequencies are identical, and the phase sequence is correct then the voltage across L1 will be zero and across L2 and L3 will be line voltage.

Under this condition, the lamp L1 will be completely dark, and the lamp L2 and L3 will be equally bright. This is the ideal condition for closing the synchronizing switch.

When the frequency of the incoming alternator is different from that of bus bar frequency and the remaining conditions are fulfilled, then the three lamps will flicker alternatively (i.e. one after the other in sequence).

The flickering of the lamps will indicate the difference in speed of the incoming alternator. Accordingly, the speed is adjusted to minimize the flickering of the lamps.

However, if the phase sequence is not correct, all the three lamps will flicker in unison. Then the phase sequence should be corrected by interchanging any two leads of the incoming alternator at the synchronizing switch.

If the voltage of the incoming alternator is not equal to that of bus bar voltages and the other conditions are satisfied, all the lamps will glow with different brightness and will continue to

attain the same brightness. The ideal condition can be achieved by adjusting the excitation of the incoming alternator.

Thus when the flickering frequency is minimized, lamp L1 is dark, and L2 and L3 are equally bright, the synchronizing switch should be closed.

This method is only suitable for small low voltage alternators. For large capacity, high voltage alternators, a synchroscope is almost invariably used for synchronizing.

The disadvantage of this method is that the correctness of phase sequence cannot be checked. However, this requirement is unnecessary for permanently connected alternators where checking of phase sequence is enough to be carried out for the first time of operation alone.

### 3. Synchroscope Method

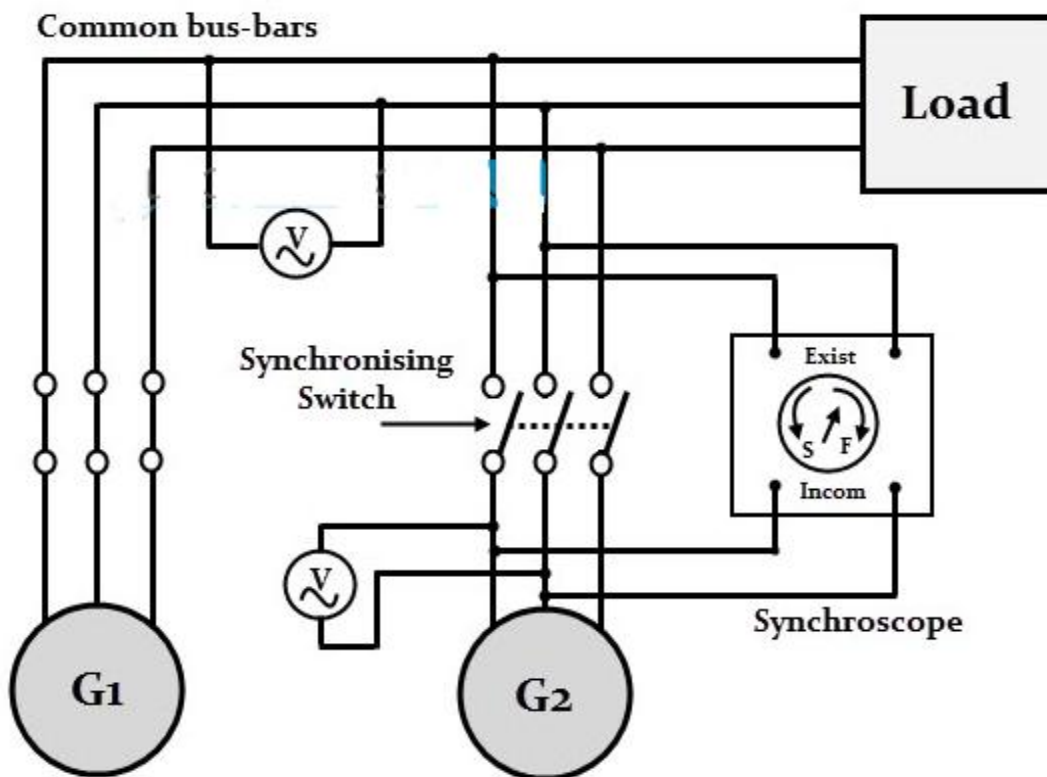

Synchroscope is an instrument used for synchronization of alternators. It indicates whether the incoming machine is running fast or slow. To do the synchronization of alternators by this device,

1. Connect the alternator, synchroscope and other devices as shown in the above Figure.

2. Check the phase sequence of the incoming machine with the help of a sequence indicator or small induction motor.

To determine the phase sequence with the help of induction motor, connect a small induction motor with bus bars and incoming alternator one by one. If the induction motor is running in the same direction in both cases, then the phase sequence is the same.

2. Interchange any two phases of the incoming alternator at the synchronizing switch if it is not correct.

3. By adjusting the speed of the incoming machine, make the pointer of synchroscope stationery in the vertical position.

4. Measure the voltage of incoming alternator, make it equal to that of the bus bars by adjusting the excitation of the incoming alternator.

5. After satisfying all these conditions, the voltmeter will show zero reading. Now close the synchronization switch.

### **SYNCHRONIZING POWER AND TORQUE WHEN TWO ALTERNATORS ARE OPERATING IN PARALLEL**

Consider an alternator connected to the infinite bus bar. Let  $V$  be the bus bar voltage and  $E$  be the EMF induced in the alternator. The excitation of the alternator is adjusted in such a way that  $E$  and  $V$  are equal in magnitude. In the local circuit, the two voltages  $E$  and  $V$  are in phase opposition while in the external circuit they are in the same phase. This is represented in the below figure.

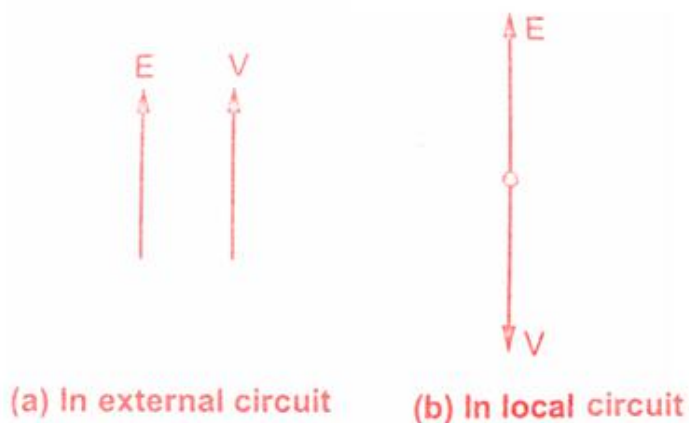

When two alternators are operating in parallel, each machine has an inherent tendency to remain synchronized.

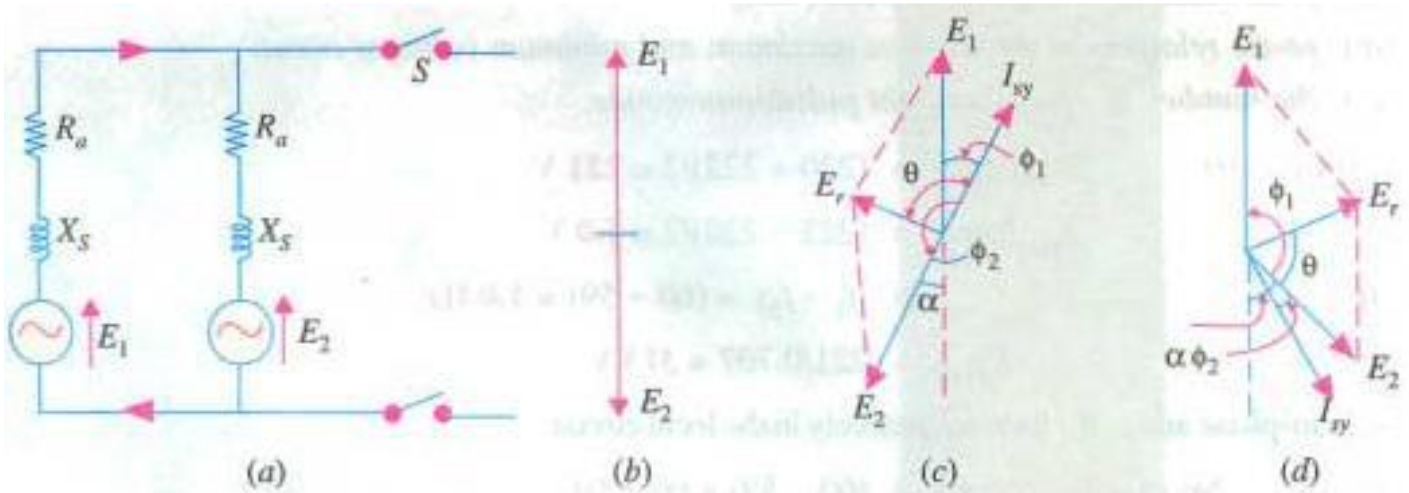

Consider two similar single-phase alternators 1 and 2 operating in parallel at no-load. Suppose, due to any reason, the speed of machine 2 decreases. This will cause  $E_2$  to fall back by a phase angle of ' $\alpha$ ' electrical degrees as shown in Fig. (though still  $E_1 = E_2$ ).

Within the local circuit formed by two alternators, the resultant e.m.f.  $E_r$  is the phasor difference  $E_1 - E_2$ . This resultant e.m.f. results in the production of synchronizing current  $I_{sy}$  which sets up synchronizing torque. The synchronizing torque retards machine 1 and accelerates machine 2 so that synchronism is reestablished.

The power associated with synchronizing torque is called synchronizing power.

In Fig, machine 1 is generating and machine 2 is motoring. The power supplied by machine 1 is called synchronizing power. Referring to Fig.

we have,

$$\begin{aligned}
 \text{Synchronizing power, } P_{sy} &= E_1 I_{sy} \cos \Phi_1 \\
 &= E_1 I_{sy} \cos (90^\circ - \theta) \\
 &= E_1 I_{sy} \sin \theta \\
 &= E_1 I_{sy} \quad (\theta \approx 90^\circ \text{ so that } \sin \theta = 1)
 \end{aligned}$$

The synchronizing power goes to supply power input to machine 2 and the  $Cu$  losses in the local circuit of the two machines.

$$\therefore E_1 I_{sy} = E_2 I_{sy} + \text{Cu losses}$$

$$\begin{aligned} \text{Resultant e.m.f., } E_r &= 2E \cos \frac{(180^\circ - \alpha)}{2} \quad [\because E_1 = E_2 = E(\text{say})] \\ &= 2E \cos \left( 90^\circ - \frac{\alpha}{2} \right) = 2E \sin \frac{\alpha}{2} = 2E \times \frac{\alpha}{2} \quad [\because \alpha \text{ is small}] \end{aligned}$$

$$\therefore E_r = \alpha E \quad (i)$$

Note that in this expression, 'α' is in electrical radians.

$$\text{Synchronizing current, } I_{sy} = \frac{E_r}{2X_s} = \frac{\alpha E}{2X_s} \quad R_a \text{ of both machines is negligible}$$

Here  $X_s$  = synchronous reactance of each machine

$\therefore$  Synchronizing power supplied by machine 1 is

$$\begin{aligned} P_{sy} &= E_1 I_{sy} \\ &= E \times \frac{\alpha E}{2X_s} = \frac{\alpha E^2}{2X_s} \quad \left( \because E_1 = E_2 \text{ and } I_{sy} = \frac{\alpha E}{2X_s} \right) \end{aligned}$$

$$\therefore P_{sy} = \frac{\alpha E^2}{2X_s} \text{ per phase}$$

Total synchronizing power for 3 phases

$$= 3P_{sy} = \frac{3\alpha E^2}{2X_s}$$

Note that this is the value of synchronizing power when two alternators, operate in parallel at no-load.

### **Alternators Connected to Infinite Busbars**

When an alternator is connected to an infinite busbars, the impedance (or synchronous reactance) of only that alternator is considered.

$$\therefore I_{sy} = \frac{E_r}{Z_s} = \frac{\alpha E}{X_s} \quad \text{if } R_a \text{ is negligible}$$

$$\therefore P_{sy} = \frac{\alpha E^2}{X_s} \text{ per phase}$$

Total synchronizing power for 3 phases

$$= 3P_{sy} = \frac{3\alpha E^2}{X_s}$$



## Synchronizing Torque $T_{sy}$

Let  $T_{sy}$  be the synchronizing torque in newton-metre (N-m).

### 1. When there are two alternators is parallel

$$3P_{sy} = \frac{2\pi N_s T_{sy}}{60}$$

$$T_{sy} = \frac{3P_{sy} \times 60}{2\pi N_s} \quad \left( \text{Here } P_{sy} = \frac{\alpha E^2}{2X_s} \right)$$

### 2. When alternator is connected to infinite Busbars

$$3P_{sy} = \frac{2\pi N_s T_{sy}}{60}$$

$$T_{sy} = \frac{3P_{sy} \times 60}{2\pi N_s} \quad \left( \text{Here } P_{sy} = \frac{\alpha E^2}{X_s} \right)$$

## **LOAD SHARING BETWEEN TWO ALTERNATORS:**

Consider two machines with identical speed-load characteristics running in parallel with a common terminal voltage of  $V$  volts and load impedance  $Z$ .

Let the generated emfs of the two machines 1 and 2 operating in parallel be  $E_1$  and  $E_2$  respectively and synchronous impedances per phase be  $Z_1$  and  $Z_2$  respectively.

Terminal voltage of machine 1 and terminal voltage of machine 2:

Consider two alternators with identical speed/load characteristics connected in parallel as shown in Fig.

Let  $E_1, E_2 =$  induced e.m.f.s per phase  
 $Z_1, Z_2 =$  synchronous impedances per phase

$Z =$  load impedance per phase

$I_1, I_2 =$  currents supplied by two machines

$V =$  common terminal voltage per phase

$$V = E_1 - I_1 Z_1 = E_2 - I_2 Z_2$$

$$\therefore I_1 = \frac{E_1 - V}{Z_1}; \quad I_2 = \frac{E_2 - V}{Z_2}$$

$$I = I_1 + I_2 = \frac{E_1 - V}{Z_1} + \frac{E_2 - V}{Z_2}$$

$$V = (I_1 + I_2)Z = IZ$$

Circulating current on no-load is

$$I_c = \frac{E_1 - E_2}{Z_1 + Z_2}$$

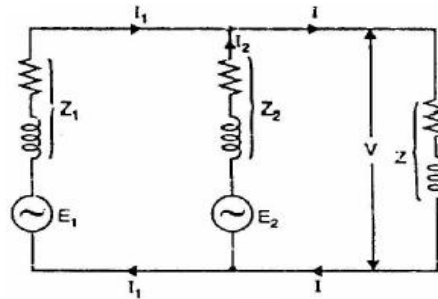

**AC MACHINES**  
**(20A02402T)**

**UNIT-IV**  
**Synchronous Motors**

**LECTURE NOTES**

10/2/20

# 5. Synchronous motor :-

The motor which works on 3- $\phi$  AC supply are called "3- $\phi$  AC motor".

→ The 3- $\phi$  AC motors are classified into 2 types

(1) 3- $\phi$  induction motor

(2) 3- $\phi$  synchronous motor

→ The basic difference between the 3- $\phi$  induction motor and synchronous motor is the 3- $\phi$  induction motor is self starting where as the 3- $\phi$  synchronous motor is not self starting.

→ The 3- $\phi$  synchronous motor always operates at it's constant speed called "synchronous speed".

→ The 3- $\phi$  synchronous motor will operate at wide ranges of power factor that is from lagging to leading.

→ The synchronous motor is double excited system.

→ An over excited synchronous motor on no load condition is called synchronous condenser and it is used for the improvement of power factor.  
construction :-

The synchronous motor consists of 2 parts

(1) stator

(2) Rotor

→ The stator is excited by 3- $\phi$  AC supply.

→ The rotor is of salient pole type. The rotor is excited by dc supply.

working principle :-

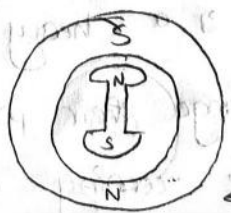

→ (b)

← Line of attraction

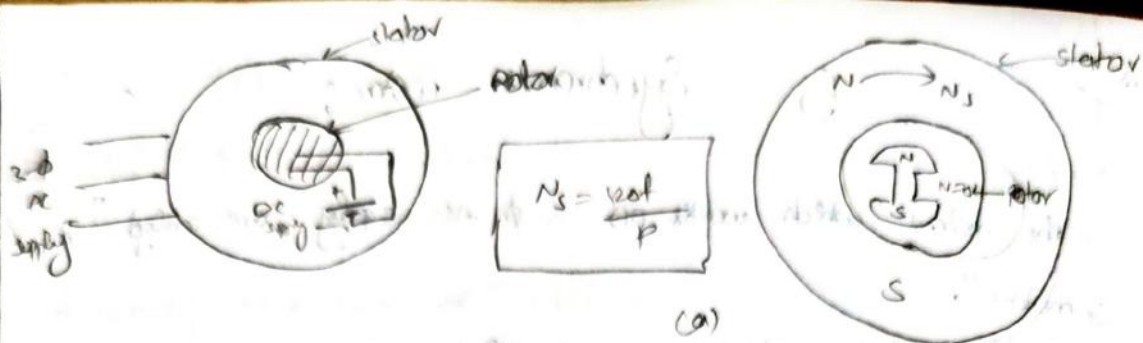

When the stator is excited by the 3-φ AC supply the stator windings will carry the current and due to these the rotating stator magnetic flux will form. (poles)

→ consider a bipolar machine.

Let the stator poles are revolving (flux) in the space with a constant speed called synchronous speed and denoted by  $N_s$  where

$$N_s = \frac{120f}{P}$$

\* Let the stator poles are revolving in clockwise direction.

→ simultaneously if the rotor is excited by the DC supply the rotor windings will carry the current and due to these the rotor poles (flux) will form.

no. of rotor poles = no. of stator poles.

→ At the time of starting the rotor is in standstill condition, and hence the rotor poles also stationary.

→ At any certain instant the stator north pole and rotor north pole, stator north pole and stator south pole will come with respect to each other as shown in figure (a).

Due to these, a force of repulsion will take place and the rotor will try to rotate in the opposite direction as that of stator poles. Since the rotor is a heavy device before these happen the stator poles will change their position as shown in figure (b). Here unlike poles are coming with respect to each other.

due to these a force of attraction will take place and the rotor will try to rotate in the same direction as that of stator poles. But before this happens again the stator poles will change their position as shown in figure (a). i.e., a force of repulsion and force of attraction will take place continuously at the time of starting.

→ Therefore the resultant force (torque) at the time of starting is zero. Hence the motor does not rotate.

→ In order to start the synchronous motor before giving the dc excitation rotate the rotor near to synchronous speed by using an external device and then give the excitation. Now the rotating rotor poles will form.

→ At any certain instant the stator and rotor poles will come with respect to each other as shown in figure (b). Due to these a force of attraction or magnetic interlocking will take place and the motor will continue to operate at synchronous speed.

→ Once the synchronism is established remove the external device.

### Starting methods of synchronous motor:

#### 1) By using pony motor:-

Pony motor is nothing but a small size induction motor. By using pony motor rotate the rotor near the synchronous speed and then give the dc excitation to the rotor. Now, the rotating rotor poles will form at any certain instant the unlike poles will come with respect to each other and the magnetic interlocking will take place and the motor will operate at synchronous speed once the synchronism (magnetic interlocking) is established remove the pony motor and the

motor will continue to operate at synchronous speed.

### ② By using damper winding :-

In this method the rotor will carry an extra field winding called damper winding in addition to the normal rotor winding.

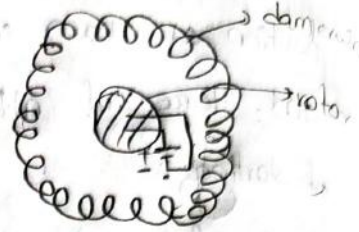

→ damper winding is nothing but an ordinary field winding but its 2 ends are permanently short circuited with the help of copper wire called end rings.

→ In this method the synchronous motor will start like a squirrel cage induction motor.

→ once the synchronous is established the damper winding will automatically cut out from the circuit.

$$At N > N_s$$

$$\begin{array}{c} E_r \propto \sum_r \propto N_s - N \\ \downarrow \quad \downarrow \quad \downarrow \\ 0 \quad \delta \quad 0 \end{array}$$

→ The main drawback of this method is it cannot develop high starting torque. so, it is used for low starting torque methods.

### ③ Starts like slipping induction motor :-

→ In order to improve the starting torque of synchronous motor in this method it will start like a slipping induction motor.

→ once the motor is operating near to synchronous speed give the dc excitation to the rotor by changing the change the switch.

→

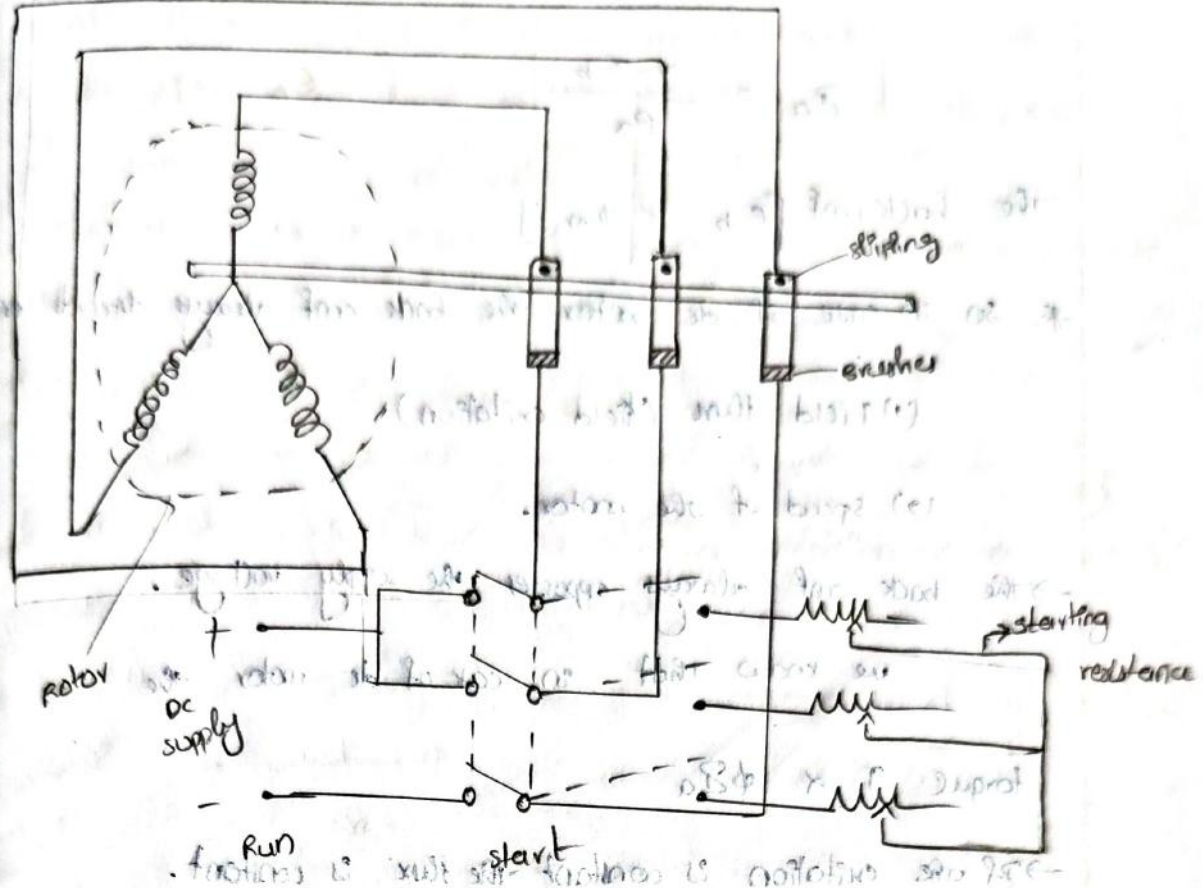

→ now, the rotating rotor poles will form and at any certain instant the magnetic interlocking will take place and the motor will operate at synchronous speed.

→ The main advantage of this method is it not only improves the starting torque, but also limits the starting current.

④ starting by using a DC machine permanently coupled to the rotor :-

→ In this method a DC machine is permanently coupled to the rotor.

→ At the time of starting the DC machine will act as DC motor by using the DC motor rotate the rotor near to synchronous speed.

→ once the synchronism is established the same DC motor will act as a generator and it will supply energy to the rotor winding.

Synchronous motor on load :- we know that in case of DC motor

$$V = E_b + I_a R_a$$

$$\boxed{Z_a = \frac{v - E_b}{R_a}}$$

$$(\because E_b \approx v)$$

The back emf  $[E_b \propto \phi \omega]$

\* so in case of dc motor the back emf always depends on

(1) Field flux (field excitation)

(2) speed of the motor.

→ The back emf always opposes the supply voltage.

we know that in case of dc motor the

$$\text{torque } T \propto \phi Z_a$$

→ If the excitation is constant the flux is constant.

Now, by keeping the excitation as constant as the load on the dc motor increases in order to develop the required torque the motor reacts by decreasing its speed.

→ so as  $\omega \downarrow$ ;  $E_b \downarrow$

As  $E_b \downarrow$ ;  $Z_a \uparrow$

As  $Z_a \uparrow$ ;  $T \uparrow$

→ Similarly in case of synchronous motor the back emf will develop and it will act in the opposite direction to the supply voltage.

$$\boxed{E_b \propto \phi_p T_{ph}}$$

$$E_b \propto \phi_p$$

we know that → the synchronous motor always operates at

$$\text{where, } N_s = \frac{120f}{P}$$

constant speed called "synchronous speed" and denoted by  $(N_s)$

$$\boxed{N_s \propto f}$$



As  $N_s$  is constant ;  $f$  is constant

$$E_b \propto \phi$$

→ in case of synchronous motor the back emf only depends on field excitation and it is independent of frequency (or) speed.

→ as similar to dc motor in case of synchronous motor

$$\bar{V} = \bar{E}_b + \bar{I}_a \bar{R}_a + j \bar{I}_a \bar{X}_s \quad (or)$$

$$\bar{V} = \bar{E}_b + \bar{I}_a (\bar{R}_a + j \bar{X}_s)$$

$$\bar{V} = \bar{E}_b + \bar{I}_a \bar{Z}_s$$

$$\bar{Z}_a = \frac{\bar{V} - \bar{E}_b}{\bar{I}_a}$$

now by keeping the excitation as constant as the load on the synchronous motor increases we know that

$$E_b \propto \phi$$

so as excitation is constant the back emf is constant, so the current will remain constant

As  $\bar{Z}_a$  is constant ;  $\bar{I}_a$  is constant

\* then how the synchronous motor develops the necessary torque

[In case of synchronous motor as the load increases]

As excitation is constant ;  $\phi$  is constant

$$T \propto \bar{Z}_a$$

$$\bar{Z}_a = \frac{\bar{V} - \bar{E}_b}{\bar{I}_a} = \frac{E_b}{I_a}$$

$$\bar{Z}_a \propto E_b$$

As the load on the synchronous motor increases, the phase difference between the supply voltage and the back emf increases, due to these the resultant voltage ( $E_R$ ) increases. As

$$E_R \uparrow ; Z_a \uparrow ; \phi T \uparrow$$

i.e., the motor will develop the required torque.

15/10/21

Per exam  
about synch motor

Case-1 :-

Synchronous motor on no load (without losses) :-

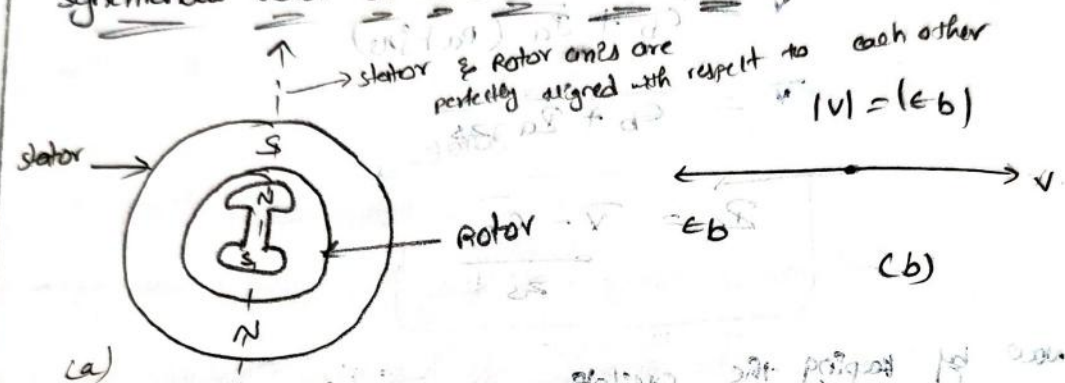

→ The ideal on no load can be assumed by neglecting the losses in the motor and  $V_{ph} = E_{bph}$

→ Under these condition the magnetic locking between the stator and rotor is such a way that the magnetic axes of both stator and rotor are perfectly aligned with respect to each other and it shown in figure (a)

→ The magnitude of the back emf  $E_b$  is equal to the supply voltage and it is in phase opposition with the supply voltage. And the phasor diagram is shown in figure (b).

$$Z_a = \frac{V - E_b}{Z_s} = 0$$

$$V = E_b = 0 \quad (* P_{in} = P_{out} + \text{losses})$$

In an ideal condition losses = 0  
on no load ;  $P_{out} = 0$

$\therefore P_{in} = 0$

→ In an ideal case on no load condition the synchronous motor does not draw any current (or) power from the supply. This condition is called floating condition of the synchronous motor.

\* But practically this is impossible.

→ In no load condition the synchronous motor has to overcome iron loss (hysteresis, eddy current losses), mechanical loss (friction and windage loss) and small amount of copper loss.

→ To overcome these losses in order to produce the torque the synchronous motor will draw the current from the supply.

Case - (2) :-

Synchronous motor on no load (with losses) :-

(In order to overcome the losses)

As excitation is constant ;  $\phi$  is constant ;  $E_b$  is constant

→ In order to overcome the losses for production of torque the rotor axis of the synchronous motor will fall back slightly with respect to stator axis but still maintaining the magnetic interlocking.

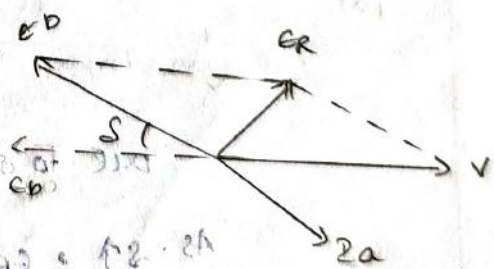
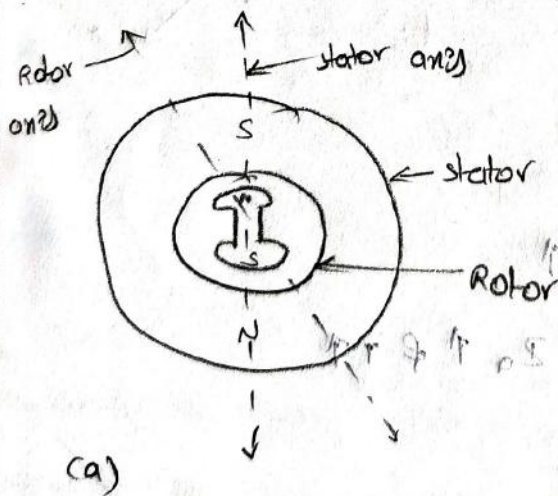

→ Due to these a phase difference between the supply voltage and the back emf will produce and the phasor diagram is shown

in figure (b).

$$\rightarrow Z_a = \frac{\sqrt{V^2 - E_b^2}}{Z_s} = \frac{E_R}{Z_s}$$

$$Z_a \propto E_R$$

$$T \propto Z_a \propto E_R \propto \delta$$

→ The value of  $\delta$  ~~decides~~ the amount of current required to produce the torque to supply the various loads.

→  $\delta$  is called "torque angle" or "coupling angle" or "angle of retardation" or "power angle" or "load angle".

18/02/25

Synchronous motor on load :- As the load on the synchronous motor increases there is no change in the speed. But in order to develop the required torque the rotor axis fall back more and more with respect to supply voltages but still maintaining the magnetic interlocking.

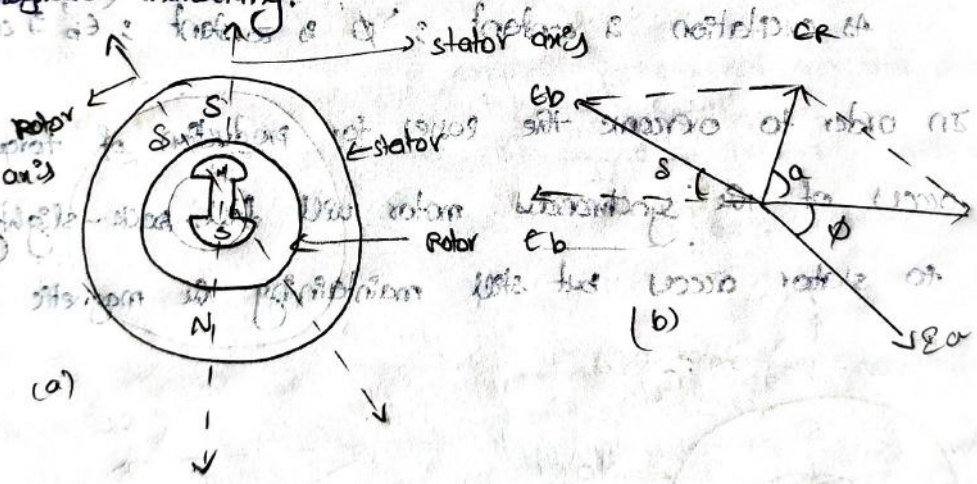

Due to this  $\delta \uparrow$

$$As - \delta \uparrow ; E_R \uparrow ; Z_a \uparrow \& T \uparrow$$

constant excitation circuit :-

We know that  $E_b \propto \phi$

As excitation is constant,  $Z_f$  is constant;  $E_b$  is constant

→ now by keeping the excitation as constant as the load on the synchronous motor increases in order to develop the required torque the value of  $\delta$  increases. i.e., the rotor axis fall back more and more with respect to stator axis but still maintaining the magnetic interlocking

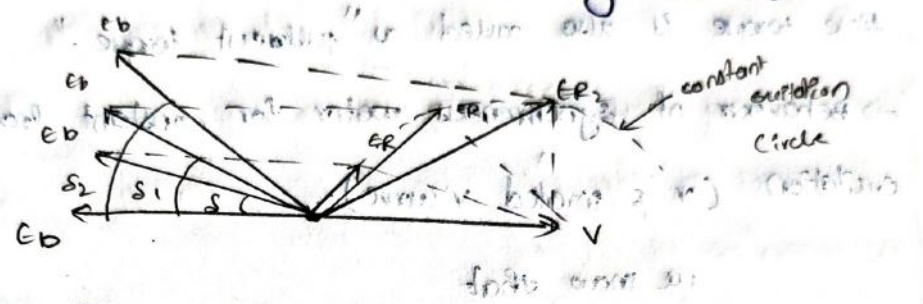

→ the locus of extremities (end points) of the resultant voltage (or) the current for constant excitation with variable load is a circle.

$$Z_a = \frac{V - E_b}{Z_s}$$

$$= \frac{E_r}{Z_s}$$

$$E_r = Z_a Z_s$$

$$E_r \propto Z_a$$

$$T_2 > T_1 > T$$

$$Z_{a2} > Z_{a1} > Z_a$$

$$E_{r2} > E_{r1} > E_r$$

$$\delta_2 > \delta_1 > \delta$$

Torque angle characteristics :-

we know that in case of synchronous motor

$$T \propto Z_a \propto E_r \propto \delta$$

As  $\delta \uparrow$ ;  $T \uparrow$

→ whenever the rotor is falling back with respect to stator axis the magnetic flux lines producing the force of attraction between the poles get more and more stretched. These weakened force maintain the magnetic locking even though the torque produced by the motor increases.

As  $\delta$  reaches to  $90^\circ$  the stretched flux lines get broken hence the magnetic locking between the stator and rotor no longer exists and the motor come out of synchronism.

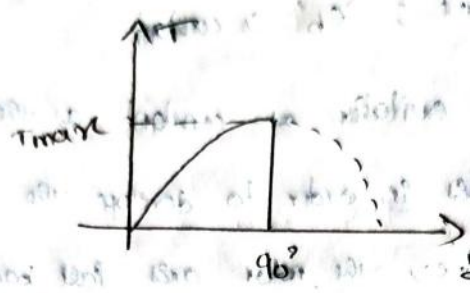

→ The torque produced at  $\delta = 90^\circ$  is called "maximum torque".  
 This torque is also called as "pullout torque".

→ Behaviour of synchronous motor for constant load with excitation (V & inverted V curve).

We know that

$$P = V I \cos \phi$$

In practice the supply voltage 'V' is constant

$$\therefore P \propto I \cos \phi$$

As load is constant; 'P' is constant

$$E_b \propto \phi \propto I_f \propto \text{excitation}$$

$$I_a = \frac{V - E_b}{Z_s} = \frac{E_R}{Z_s}$$

As excitation changes

$E_b$  changes

As ' $E_b$ ' changes,  $E_R$  changes &

$I_a$  changes

As ' $I_a$ ' changes, P changes

to maintain 'P' as constant

Immediately the motor reacts by changing its power factor.

Immediately

→ If the excitation is adjusted] consider a synchronous motor is operating at certain load and the corresponding load angle is  $\delta$ .

→ At start consider the normal behaviour of the synchronous motor and the excitation is adjusted in such a way that the back emf is approximately equal to supply voltage and this excitation is called "normal excitation". Here the synchronous motor operates at lagging power factor and the phasor diagram is shown in figure - a.

Case-1: under excitation :- If the excitation is adjusted in such a way that if  $E_b < V$  then the excitation is called "under excitation".

we know that

$$Z_a = \frac{V - E_b}{Z_s} = \frac{E_R}{Z_s}$$

If  $E_b < V$ ;  $(V - E_b) \uparrow$ ;  $E_R \uparrow$

As  $E_R \uparrow$ ;  $Z_a \uparrow$

As  $Z_a \uparrow$ ;  $\phi \uparrow$

To maintain 'p' as constant

→ here the current lags more and more with respect to supply voltage.

→ So the synchronous motor operates at lagging power factor when it is under excitation.

Case-2 :- over excitation :- If the excitation is adjusted in such a way that if  $E_b$  is > supply voltage  $E_b > V$  then the excitation is called "over excitation".

Case-3 :-

→ here the current lags more and more with respect to supply voltage.

→ So the synchronous motor operates at lagging power factor when it is under excitation.

$$Z_a = \frac{V - E_b}{Z_s} = \frac{E_R}{Z_s}$$

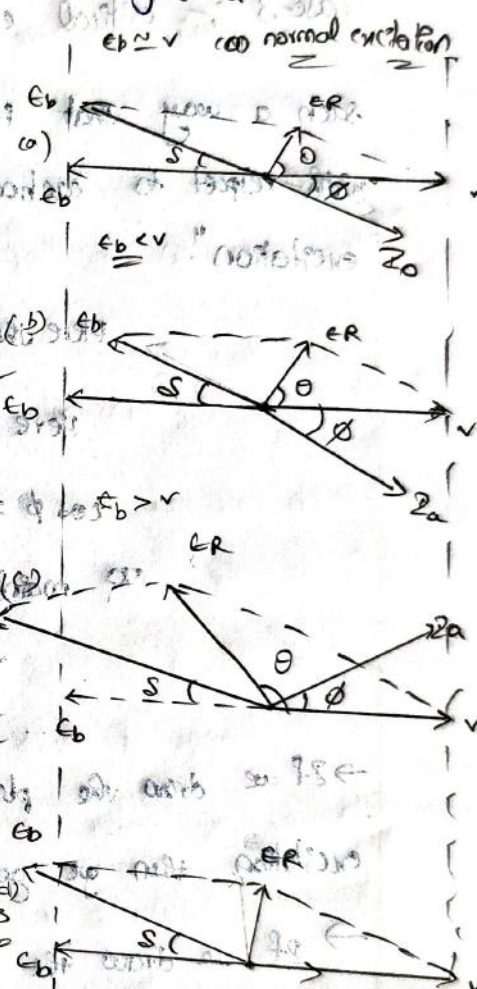

$\Sigma I_{cb} \uparrow ; (\sqrt{V - I_{cb}}) \uparrow ; E_f \uparrow$   
 As  $E_f \uparrow ; \Sigma a \uparrow$   
 As  $\Sigma a \uparrow ; P \uparrow$   
 to maintain 'P' as constant  
 $\cos \phi \downarrow$  i.e.,  $\phi \uparrow$

\* but here the current is leading with respect to supply voltage

Case-3 :- critical excitation :- If the excitation is adjusted in such a way that if both the voltage and current are in phase with respect to each other then the excitation is called "critical excitation".

Here the power factor is unity

Here  $\phi = 0$

$\cos \phi = 1$  & is maximum

to maintain 'P' as constant

'Z' is minimum

→ If we draw the plot between the armature current and the field excitation then we get the V curve and it is shown in figure (e)

→ If we draw the plot between the power factor and the field excitation then we get the inverted V curve and it is shown in figure (f).

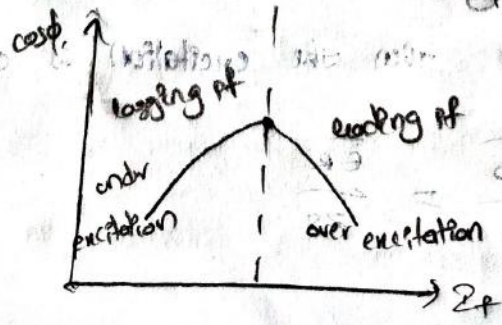
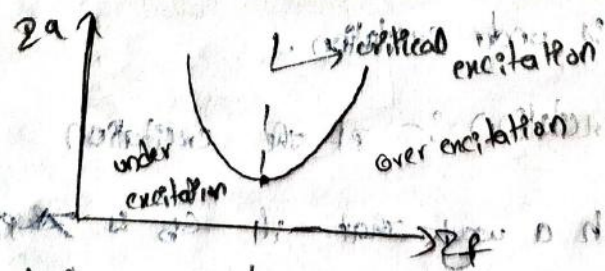



Synchronous condenser (or) synchronous capacitor :- we know that

when synchronous motor is over excited it operates at leading power factor.

→ on no load condition the value of  $S$  is very small so if the synchronous motor is over excited on no load condition the current almost leads the supply voltage by an angle of  $S$ . And is similar to capacitor.

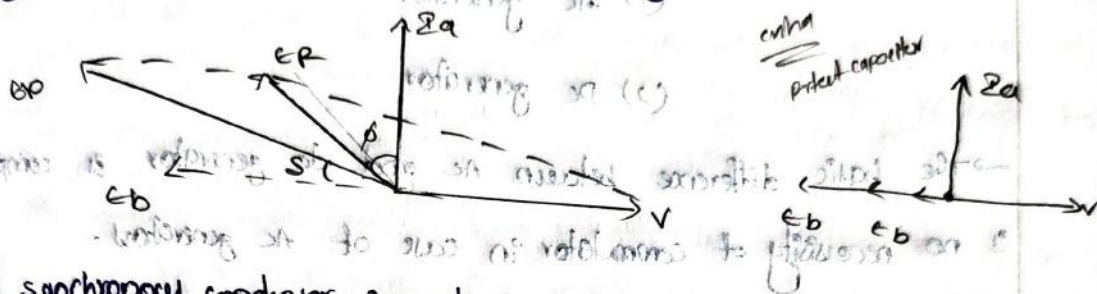

→ The synchronous condenser is used for the improvement of power factor.

Disadvantages of low power factor :-

→ we know that,

$$P = VI \cos \phi$$

As  $V$  is constant

$$P \propto I \cos \phi$$

As  $\cos \phi \downarrow$ ,  $I \uparrow$

→ i.e., the size of conductor is increases and hence the cost increases.

→ As  $I$  increased  $I^2 R$  losses increases and the efficiency decreases.

→ large current causes large voltage drops in transmission lines, generators and other equipments. due to these the voltage regulation will become poor, so to compensate the voltage drop extra equipment is necessary which increases the cost.

**AC MACHINES**  
**(20A02402T)**

**UNIT-V**

**Single-Phase Induction Motors**

**LECTURE NOTES**

## UNIT-III

### SINGLE PHASE INDUCTION MOTORS

Single-phase a.c supply is commonly used for lighting purpose in shops, offices, houses, schools etc..Hence instead of d.c motors, the motors which work on single-phase a.c. supply are popularly used. These a.c motors are called single-phase induction motors. A large no. of domestic applications use single-phase induction motors.

The power rating of these motors is very small. Some of them are even fractional horsepower motors, which are used in applications like small toys, small fans, hairdryers etc.

#### **Construction of Single Phase Induction Motors:**

The schematic diagram of two-pole single phase induction motor is shown in the below figure:

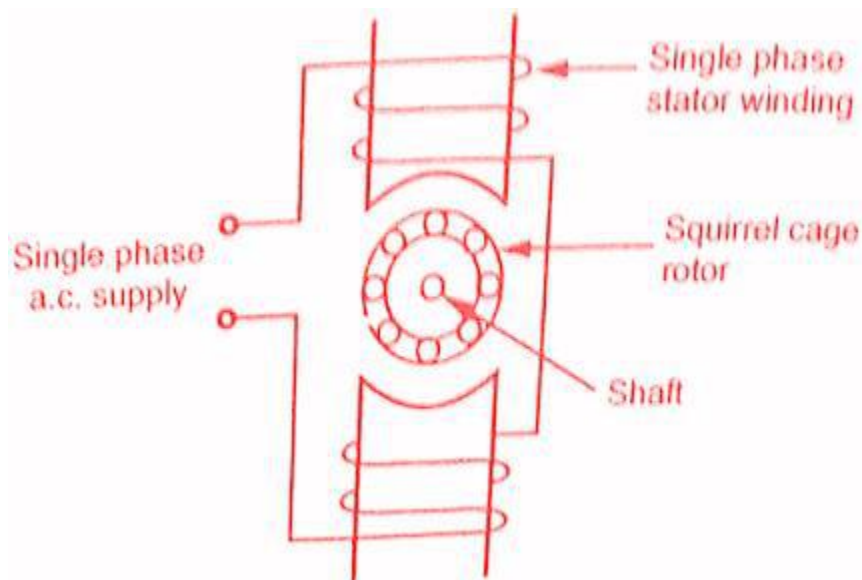

**Similar to a d.c motor, single-phase induction motor also has two main parts, one rotating and other stationary. The stationary part in single-phase induction motors is Stator and the rotating part is Rotor.**

#### **Stator**

- The stator has laminated construction, made up of stampings. The stampings are slotted on its periphery to carry the winding called stator winding or main winding.
- This is excited by a single-phase a.c supply.

- The laminated construction keeps iron losses to the minimum. The stampings are made up of material from silicon steel which minimizes the hysteresis loss.
- The stator winding is wound for a certain definite number of poles means when excited by single-phase a.c supply, stator produces the magnetic field which creates the effect of the certain definite number of poles.
- ***The number of poles for which stator winding is wound decides the synchronous speed of the motor.*** The synchronous speed is denoted as  $N_s$  and it has a fixed relation with supply frequency  $f$  and number of poles  $P$ . The relation is given by,

$$N_s = 120f/p \text{ rpm}$$

The induction motor never rotates with the synchronous speed but rotates at a speed that is slightly less than the synchronous speed.

### Rotor

- The rotor construction is of squirrel cage type.
- This rotor consists of uninsulated copper or aluminium bars, placed in the slots.
- The bars are permanently shorted at both the ends with the help of conducting rings called end rings.
- The entire structure looks like cage hence it is called a squirrel cage rotor. The construction of single-phase induction motors is shown in below figure:

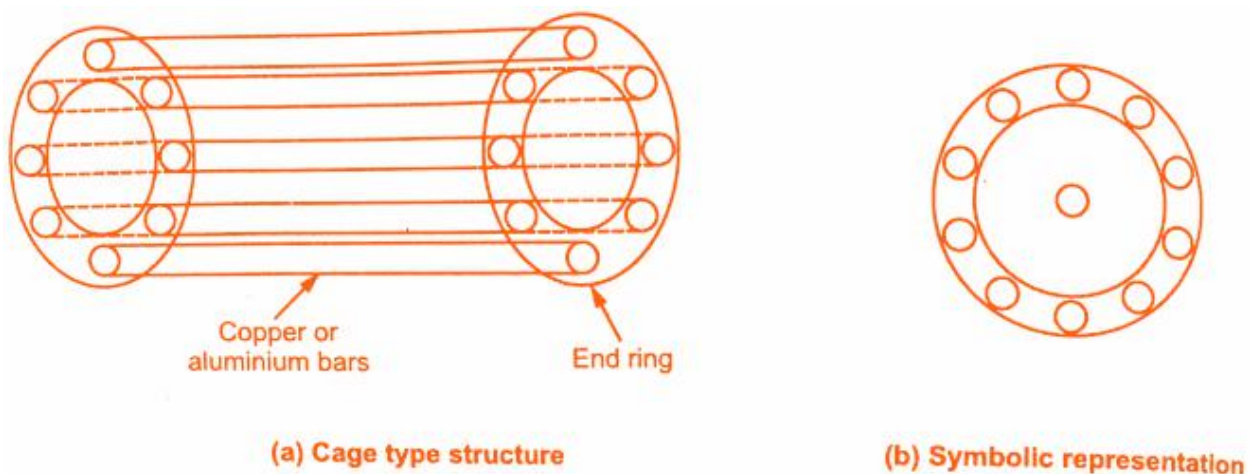

- As the bars are permanently shorted to each other, the resistance of the entire rotor is very very small. The air gap between stator and rotor is kept uniform and as small as possible.

- The main feature of this rotor is that it automatically adjusts itself for the same the number of poles as that of the stator winding.

### **Working Principle of Single Phase Induction Motors:**

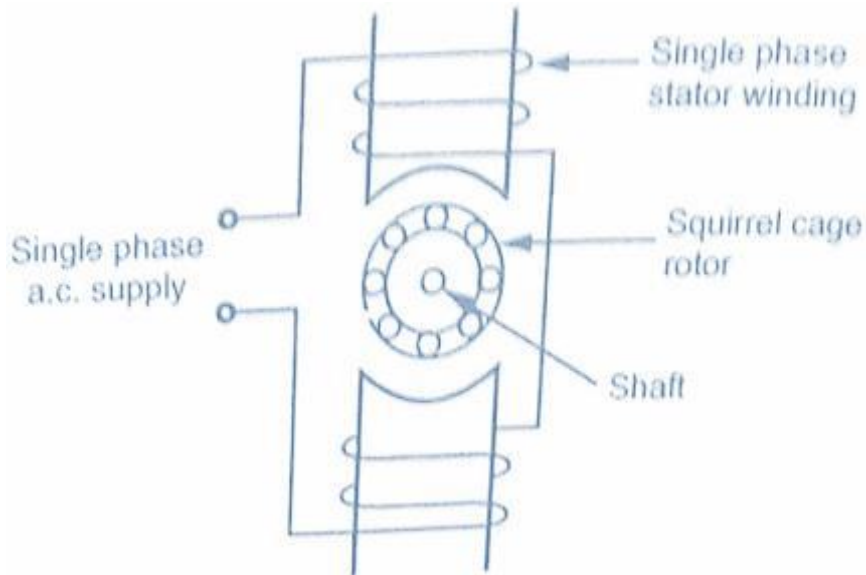

- For the motoring action, there must exist two fluxes which interact with each other to produce the torque.
- In the single-phase induction motor, single-phase a.c supply is given to the stator winding. The stator winding carries an alternating current which produces the flux which is also alternating in nature. This flux is called the main flux.
- This flux links with the rotor conductors and due to transformer action e.m.f gets induced in the rotor. The induced emf drives current through the rotor as the rotor circuit is the closed circuit.
- This rotor current produces another flux called rotor flux required for the motoring action. Thus second flux is produced according to the induction principle due to induced e.m.f hence the motor is called induction motor.

***As against this in d.c motor a separate supply is required to the armature to produce armature flux. This is an important difference between d.c motor and an induction motor.***

### Double Revolving Field Theory in single-phase induction motors:

- According to this theory, any alternating quantity can be resolved into two rotating components which rotate in opposite directions and each having magnitude as half of the maximum magnitude of the alternating quantity.
- In case of single-phase induction motors, the stator winding produces an alternating magnetic field having the maximum magnitude of  $\Phi_{1m}$ .
- According to double-revolving field theory, consider the two components of the stator flux, each having magnitude half of maximum magnitude of stator flux i.e ( $\Phi_{1m}/2$ ). Both these components are rotating in opposite directions at the synchronous speed  $N_s$  which is dependent on frequency and stator poles.
- Let  **$\Phi_f$  is forward component rotating in anticlockwise direction** while  **$\Phi_b$  is the backward component rotating in a clockwise direction.**
- The resultant of these two components at any instant gives the instantaneous value of the stator flux at that instant. So resultant of these two is the original stator flux. The below figure shows the stator flux and its two components  $\Phi_f$  and  $\Phi_b$ .
- At the start, both the components are shown the opposite to each other in figure (a). Thus the resultant  $\Phi_R = 0$ . This is nothing but the instantaneous value of stator flux at the start.
- After  $90^\circ$ , as shown in figure (b), the two components are rotated in such a way that both are pointing in the same direction.
- Hence the resultant  $\Phi_R$  is the algebraic sum of the magnitudes of the two components. So  $\Phi_R = (\Phi_{1m}/2) + (\Phi_{1m}/2) = \Phi_{1m}$ .
- This is nothing but the instantaneous value of the stator flux at  $\theta = 90^\circ$  as shown in figure (c).
- Thus continuous rotation of two components gives the original alternating stator flux.

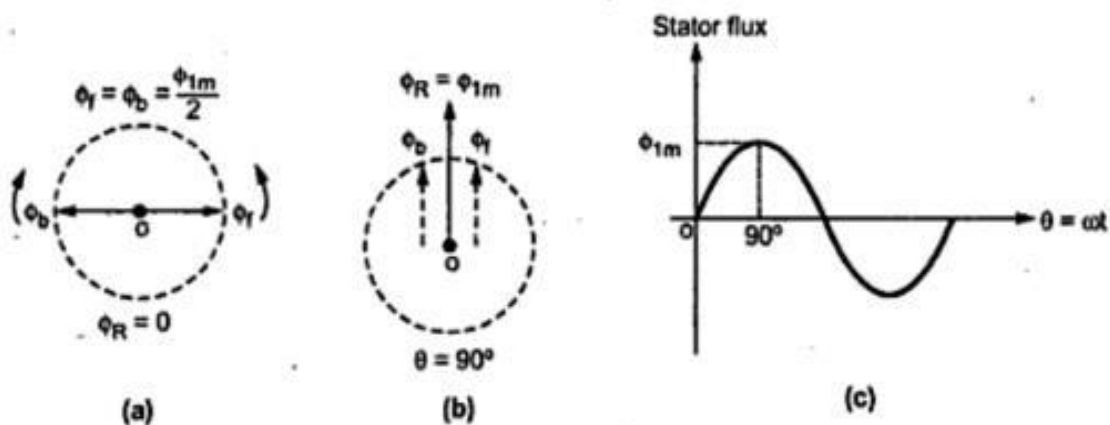

Both the components are rotating and hence get cut by the motor conductors. Due to cutting of flux, e.m.f. gets induced in rotor which circulates rotor current. The rotor current produces rotor flux. This flux interacts with forward component  $\Phi_f$  to produce a torque in one particular direction say anticlockwise direction. While rotor flux interacts with backward component  $\Phi_b$  to produce a torque in the clockwise direction. So if anticlockwise torque is positive then clockwise torque is negative.

At start these two torque are equal in magnitude but opposite in direction. Each torque tries to rotate the rotor in its own direction. Thus net torque experienced by the rotor is zero at start. And hence the single phase induction motors are not self starting.

### Torque speed characteristics

The two oppositely directed torques and the resultant torque can be shown effectively with the help of torque-speed characteristics. It is shown in the Fig.2.

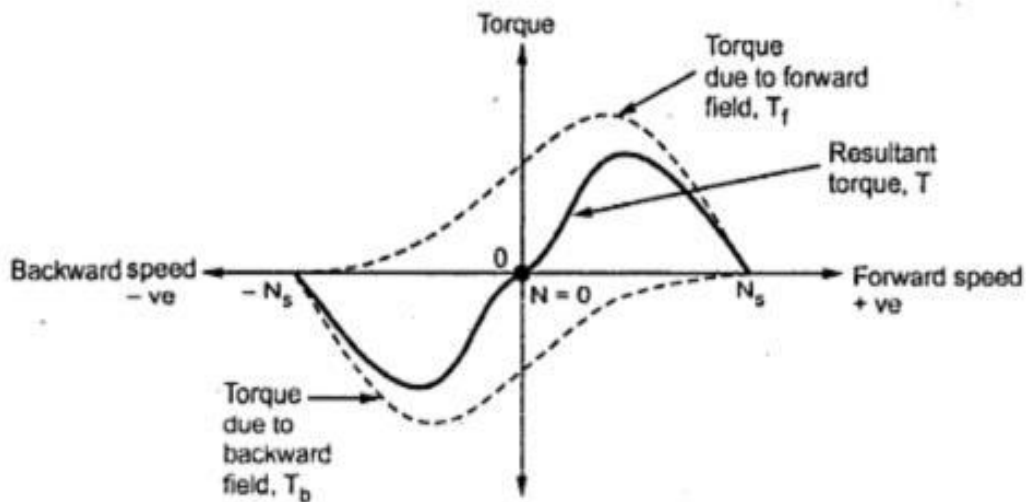

It can be seen that at start  $N = 0$  and at that point resultant torque is zero. So single phase motors are not self starting.

However if the rotor is given an initial rotation in any direction, the resultant average torque increase in the direction in which rotor initially rotated. And motor starts rotating in that direction. But in practice it is not possible to give initial torque to rotor externally hence some modifications are done in the construction of single phase induction motors to make them self starting.

### Equivalent Circuit:

The equivalent circuit of a single phase induction motor can be developed on the basis of two revolving field theory. To develop the equivalent circuit it is necessary to consider standstill or blocked rotor conditions. The motor with a blocked rotor merely acts like a transformer with its secondary short circuited and its equivalent circuit will be as shown in fig: 1.6 (a),  $E_m$  being e.m.f. induced in the stator.

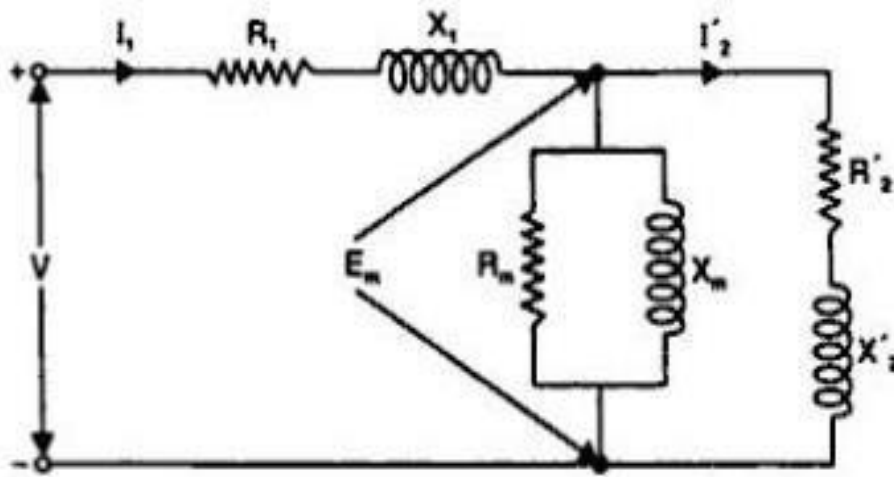

**Fig: 1.6 (a) Equivalent Circuit of a Single Phase Induction Motor**

The motor may now be viewed from the point of view of the two revolving field theory. The two flux components induce e.m.f.  $E_{mf}$  and  $E_{mb}$  in the respective stator winding. Since at standstill the two oppositely rotating fields are of same strength, the magnetizing and rotor impedances are divided into two equal halves connected in series as shown in figure:1.6 (b)

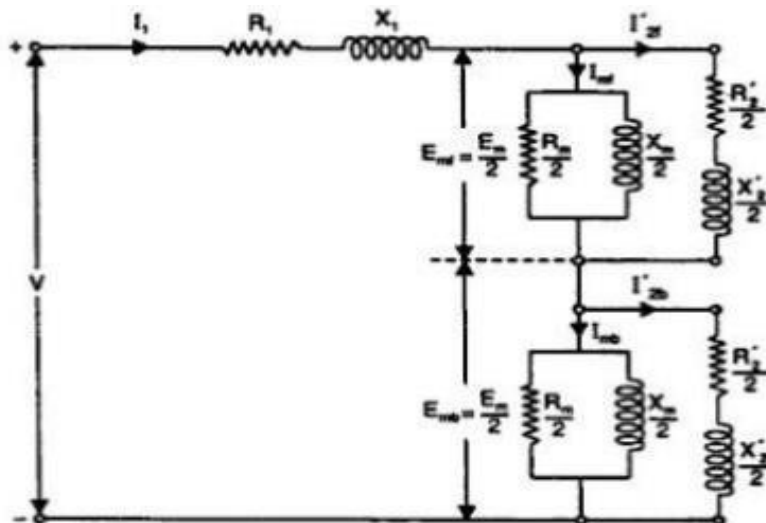

**Fig: 1.6 (b) Equivalent Circuit of Single Phase Induction Motor at Standstill on the basis of Two Revolving Field Theory**



When the rotor runs at speed  $N$  with respect to forward field, the slip is  $S$  w.r.t. forward field and  $(2-S)$  w.r.t. backward field and the equivalent circuit is as shown in fig:1.6(c)

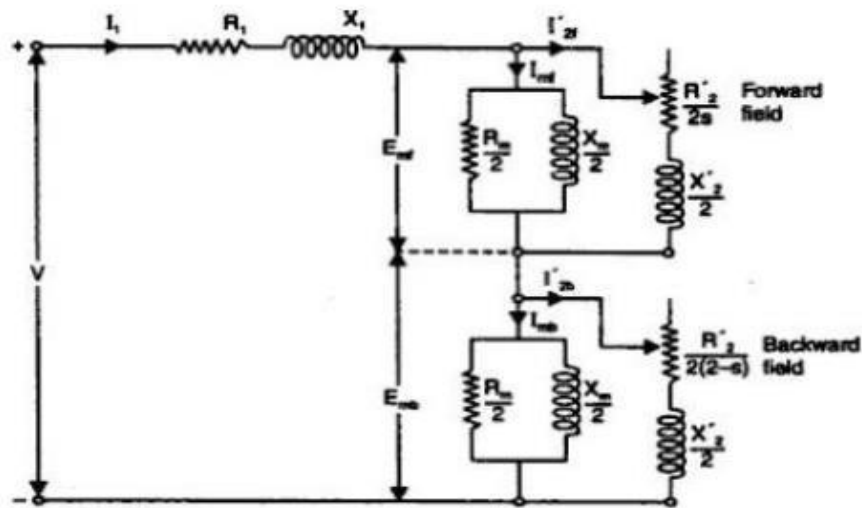

**Fig:1.6 (c) Equivalent Circuit of a Single Phase Induction Motor Under Normal Operating Conditions**

If the core losses are neglected the equivalent circuit is modified as shown in fig:1.6(d). The core losses, here, are handled as rotational losses and subtracted from the power converted into mechanical power; the amount of error thus introduced is relatively small.

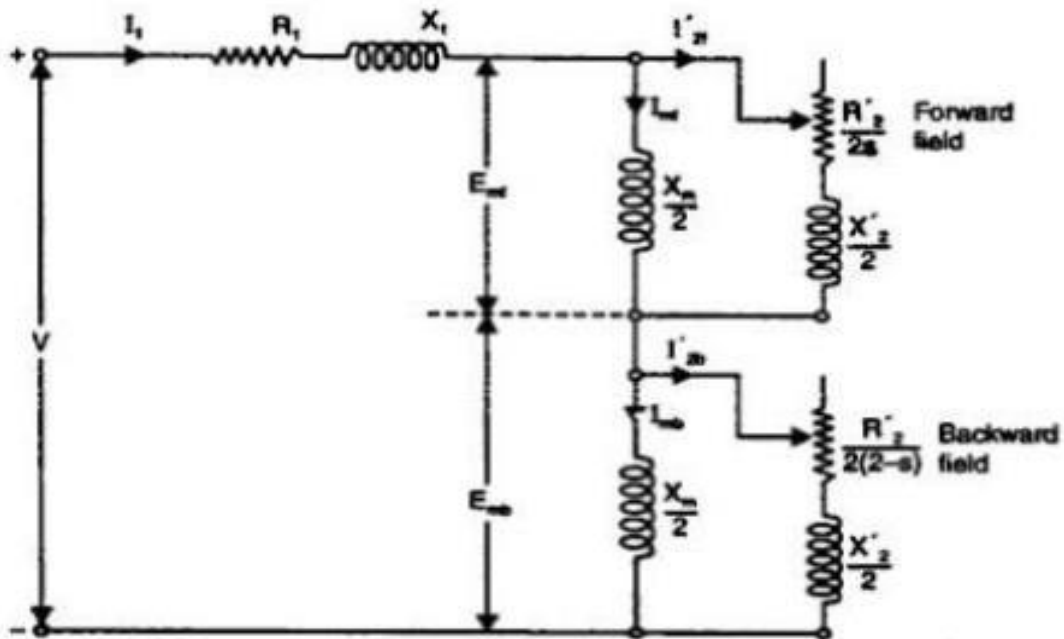

**Fig:1.6 (d) Approximate Equivalent Circuit of a Single Phase Induction Motor Under Normal Operating Conditions**

## SINGLE-PHASE INDUCTION MOTORS

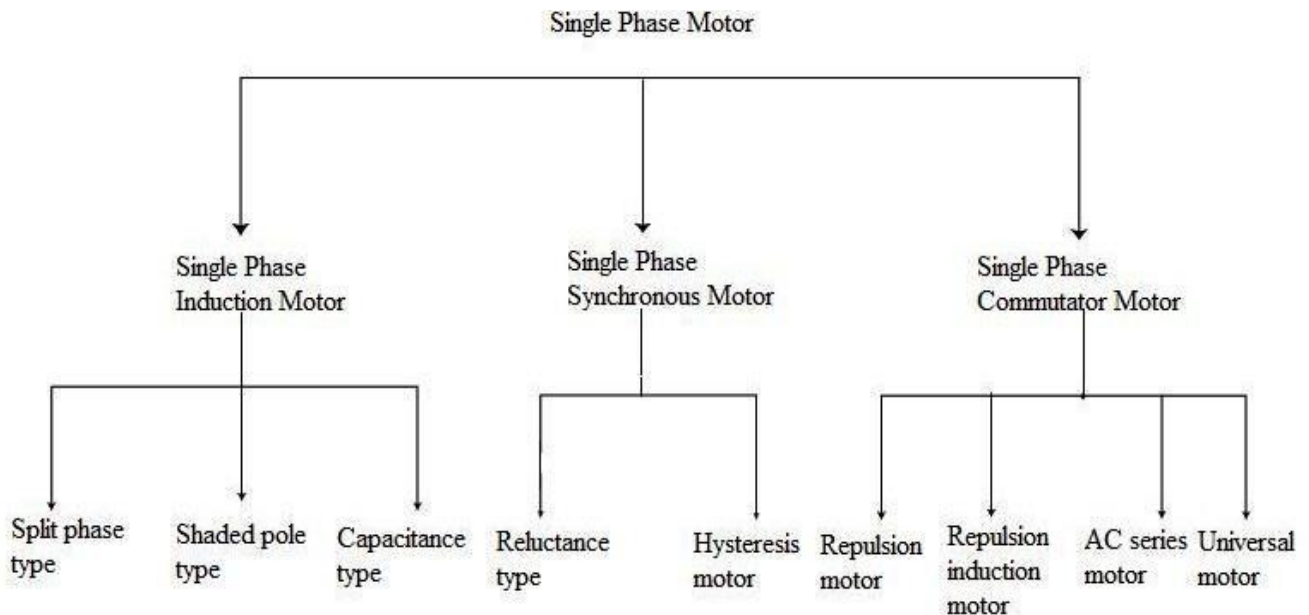

Single-phase induction motors are made self-starting by providing additional flux by some supplementary means.

Single-phase induction motors are classified depending on how this additional flux is generated:

1. Split phase induction motor.
2. Capacitor-start inductor motor.
3. Capacitor-start capacitor-run induction motor (two-value capacitor method. Used to both start and run the motor).
4. Permanent split capacitor (PSC) motor.
5. Shaded pole induction motor.

### **Split Phase Induction Motor**

In addition to the main winding or running winding, a single-phase induction motor's stator carries another winding called auxiliary winding or starting winding. A centrifugal switch is connected in series with auxiliary winding.

This switch aims to disconnect the auxiliary winding from the main circuit when the motor attains a speed up to 75 to 80% of the synchronous speed.

We know that the running winding is inductive in nature. We aim to create the phase difference between the two winding, and this is possible if the starting winding carries high resistance.

In the figure below, the variables represent:

- $I_{run}$  is the current flowing through the main or running winding,

- $I_{start}$  is the current flowing in starting winding,
- $V_T$  is the supply voltage.

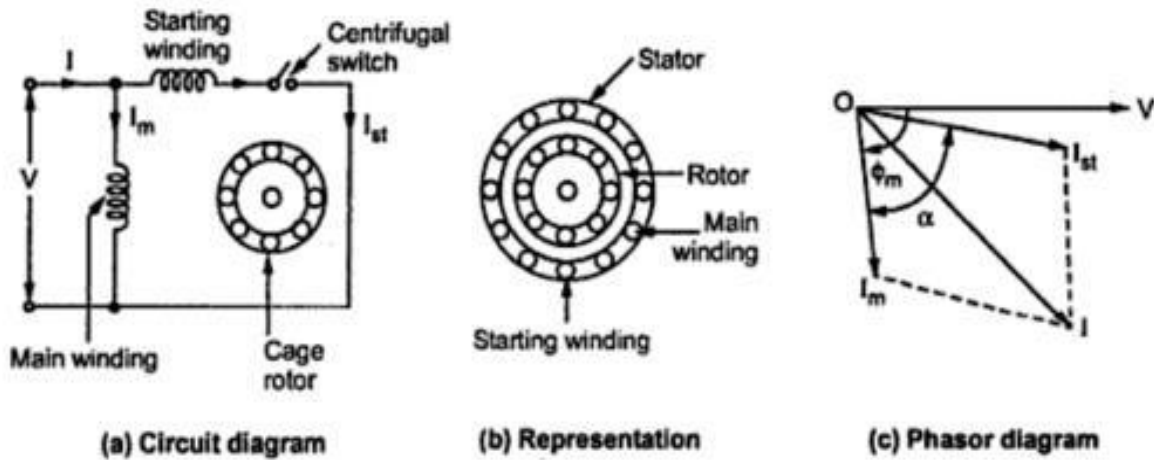

For a highly resistive winding, the current is almost in phase with the voltage, and for a highly inductive winding, the current lag behind the voltage by a large angle.

The starting winding is highly resistive so, the current flowing in the starting winding lags behind the applied voltage by a very small angle and the running winding is highly inductive in nature so, the current flowing in running winding lags behind applied voltage by a large angle.

The resultant of these two current is  $I_T$ —the resultant of these two current produce rotating magnetic field which rotates in one direction.

In a **split-phase induction motor**, the starting and main current get split from each other by some angle, so this motor got its name as a split-phase induction motor.

The torque-speed characteristics of split phase motors is shown in the Fig

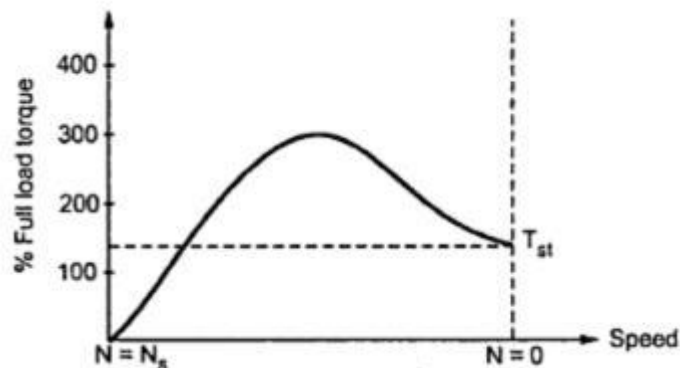

### Applications of Split Phase Induction Motor

Split phase induction motors have low starting current and moderate starting torque.

These motors are used in fans,

- Blowers,
- Centrifugal pumps,
- Washing machines,
- Grinders,
- lathes,
- Air conditioning fans, etc.

These motors are available in size ranging from 1/20 to 1/2 KW.

### Capacitor Start Motor

In the capacitor start motor capacitor  $C$  is of large value such that the motor will give high starting torque. Capacitor employed is short time duty rating. The capacitor is of electrolytic type. Electrolytic capacitor  $C$  is connected in series with the starting winding along with centrifugal switch  $S$  as shown in the diagram.

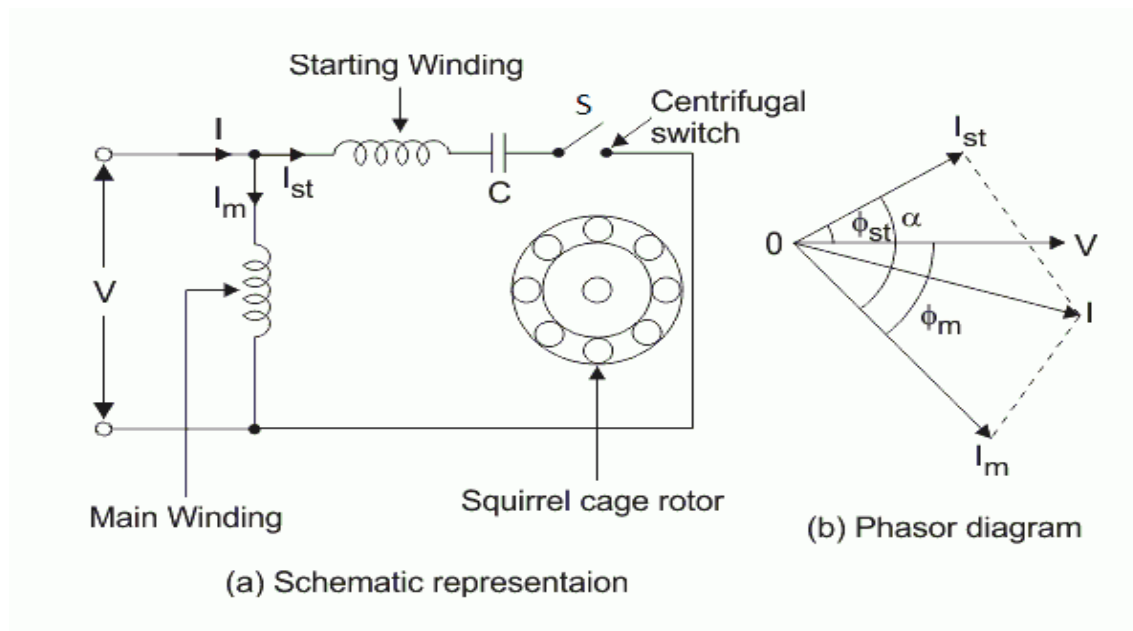

When the motor attains the speed of about 75% of synchronous speed starting winding is cut-off.

The construction of the motor and winding is similar to usual split phase motor.

The capacitor start motor is used where high starting torque is required like refrigerators.

### Characteristics of Capacitor Start Motor

- Speed is constant within 5% slip.
- *Capacitor start motor* develops high starting torque about 4 to 5 times the full load torque and reduces the starting current.

- The direction of rotation can be changed by interchanging the connection of supply to the either of the winding.

These motors are used for the loads of higher inertia where frequent starting is required. Used in

- Pumps
- Compressors.
- Refrigerators
- Air Conditioner Compressors
- Conveyors
- Machine Tools.

### Capacitor Run Motor Working

Connection scheme for the capacitor run motor is the same as the capacitor start motor except for the absence of centrifugal switch  $S$ .

The capacitor is of paper type. The capacitor is permanently connected to the starting winding. In case of the paper capacitor, the value of the capacitance is small since it is difficult and becomes uneconomical to manufacture paper capacitor of higher value.

The electrolytic capacitor cannot be used since this type of capacitor is used for only short time rating and hence cannot be permanently connected to the winding. Both main as well as starting winding is of equal rating

### Characteristics of Capacitor Run Motor

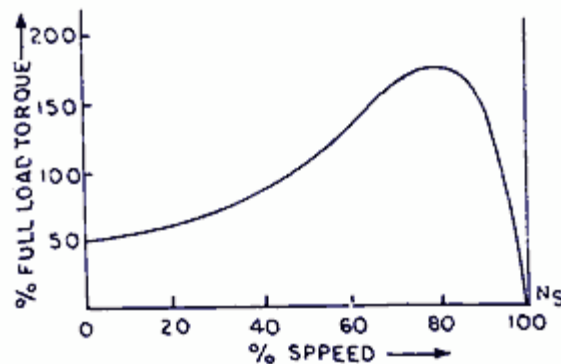

- Starting torque is lower about 50% of full load torque. Power factor is improved. It may be about unity. Efficiency is improved to about 75%.
- The direction of rotation can be reversed as written in case of capacitor start motor.

- The **capacitor run motor** is used in fans, room coolers, portable tools and other domestic and commercial electrical appliances.

## Capacitor Start Capacitor Run Motor

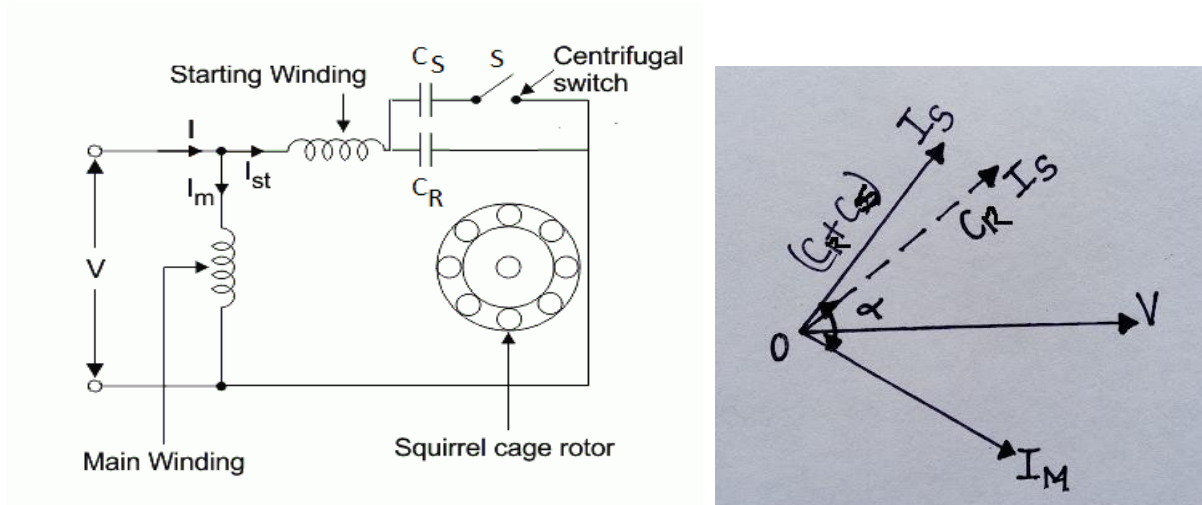

Two capacitors are used in **capacitor start capacitor run motor** or two value capacitor motor, one for starting purpose and other for running purpose. Starting purpose capacitor is of electrolytic type and is disconnected from the supply when the motor attains 75% of synchronous speed with the help of centrifugal switch  $S$ , connected in series with  $C_s$ . The value of the two capacitors is different. Starting capacitor  $C_s$ , which is electrolytic type, is of high value.

### Characteristics of Capacitor Start Capacitor Run Motor

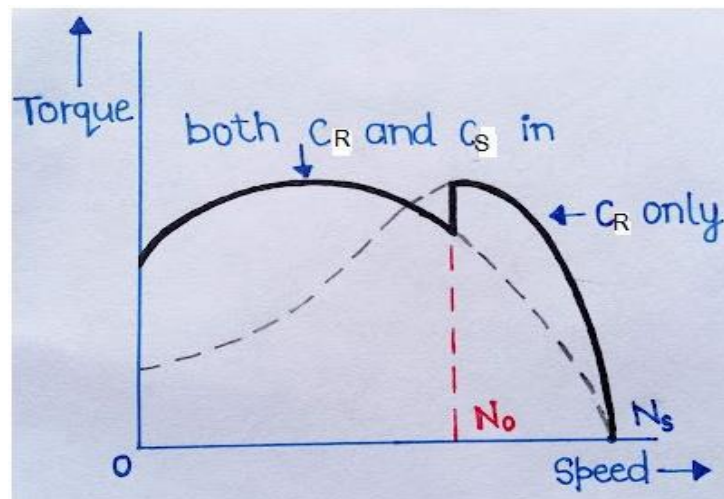

- The *capacitor start capacitor run motor* gives the best running as well as starting conditions. Such motors operate as two-phase motors giving the best performance.

- Starting torque is high, starting current is reduced and gives better efficiency, better p.f. The only disadvantage is high cost.
- Direction can be reversed by interchanging the connection of supply to either of the main winding or starting winding.

**Capacitor start capacitor run induction motors are used in applications like**

- Compressors,
- Conveyors,
- Refrigerators,
- Air Conditioners,
- Ceiling Fans Etc.

### SHADED POLE INDUCTION MOTOR

**Shaded pole induction motor** is constructed with salient poles in the stator. Each pole has its own exciting coil. A 1/3rd portion of each pole core is surrounded by a strap of copper forming a closed loop called the shading coil. The rotor is a usual squirrel cage type.

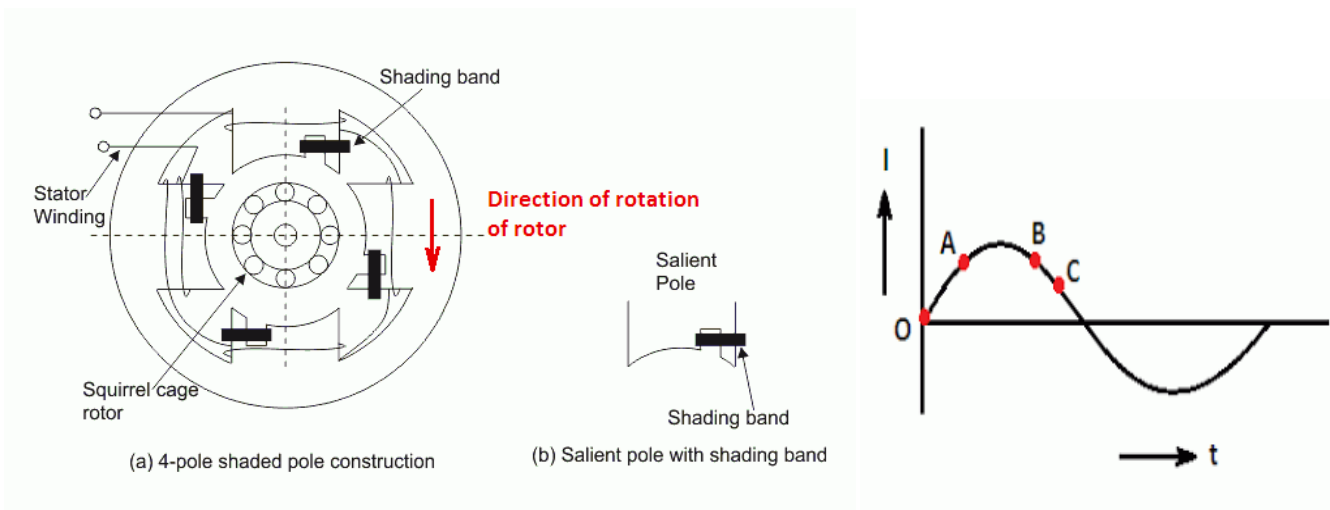

### Shaded Pole Induction Motor Working Principle

1. During the portion *OA* of the alternating-current cycle, the flux begins to increase and an EMF is induced in the shading coil. This flux induces voltage and hence current in the copper ring, and by Lenz's law, the direction of current is such that it opposes the flux entering the coil. Hence, in the beginning, the greater portion of flux passes through the unshaded side of each pole.

2. During the portion *AB* of the alternating-current cycle, the flux has reached almost maximum value and is not changing. Consequently, the flux distribution across the pole is uniform since no current is flowing in shading coil.
3. As the flux decreases (portion *BC* of the alternating-current cycle) the current induced in shading coil now tends to prevent the flux linking with shading coil from decreasing and hence the greater portion of flux passes through the shaded side of each pole.
4. **Thus the flux reaches its maximum value first at the shaded side of the pole and later reaches its maximum on the unshaded side of the pole. This gives a motion of flux across the pole face in the direction of arrow (in the direction of rotation of rotor) as shown in the figure above.**
5. Under the influence of this flux small starting torque is produced. As soon as this torque starts to revolve the rotor, additional torque is produced for running because of the single phase induction motor action. The *shaded pole motor* accelerates to a speed slightly below synchronous speed and runs as single phase motor.

#### **Characteristics of Shaded Pole Induction Motor**

1. **Shaded pole induction motor produces very small starting torque about 50% of full load torque.**
2. Efficiency of shaded pole motor is low because of continuous power loss in shading coil.
3. Used for small fans and small appliances.
4. **The direction of rotation of shaded pole motor depends upon the position of shading coil** i.e. which half of pole is wrapped with shading coil. Therefore, the direction of rotation cannot be reversed unless the machine is constructed so that the shading coil can be shifted to another half of the pole.



## RELUCTANCE MOTOR

The reluctance motor has basically two main parts called stator and rotor. The stator has a laminated construction, made up of stampings.

The stampings are slotted on its periphery to carry the winding called stator winding. The stator carries only one winding. This is excited by single-phase a.c. supply. The laminated construction keeps iron losses to a minimum. The stampings are made up of material from silicon steel which minimises the **hysteresis loss**. The stator winding is wound for certain definite number of poles.

The rotor has a particular shape. Due to its shape, the air gap between stator and rotor is not uniform. No d.c. supply is given to the rotor. The rotor is free to rotate. The reluctance i.e., the resistance of the magnetic circuit depends on the air gap. More the air gap, more is the reluctance and vice-versa. Due to the variable air gap between stator and rotor, when the rotor rotates, reluctance between stator and rotor also changes.

The stator and rotor are designed in such a manner that the variation of the inductance of the windings is sinusoidal with respect to the rotor position.

The **construction of Reluctance Motor** is shown in figure (a) while the practical rotor of **Reluctance Motor** is shown in figure(b) below.



### Working Principle of Reluctance Motor:

The stator consists of a Single Winding called main winding. But single winding cannot produce rotating magnetic field. So for production of rotating magnetic field, there must be at least two windings separated by the certain phase angle. Hence stator consists of an additional winding called auxiliary winding which consists of a capacitor in series with it.

Thus there exists a phase difference between the currents carried by the two windings and corresponding fluxes. Such two fluxes react to produce the rotating magnetic field. The technique is called split phase technique of production of the rotating magnetic field. The speed

of this field is the synchronous speed which is decided by the number of poles for which stator winding is wound.

The rotor carries the short-circuited copper or aluminium bars and it acts as a squirrel-cage rotor of an **induction motor**. If an iron piece is placed in a magnetic field, it aligns itself in a minimum reluctance position and gets locked magnetically. Similarly, in the **reluctance motor**, rotor tries to align itself with the axis of rotating magnetic field in a minimum reluctance position. But due to rotor inertia, it is not possible when the rotor is standstill.

So rotor starts rotating near synchronous speed as a **squirrel cage induction motor**. When the rotor speed is about synchronous, stator magnetic field pulls rotor into synchronism i.e. minimum reluctance position and keeps it magnetically locked. Then rotor continues to rotate with a speed equal to synchronous speed. Such a torque exerted on the rotor is called the reluctance torque. Thus finally the **reluctance motor** runs as a synchronous motor. The resistance of the rotor must be very small and the combined inertia of the rotor and the load should be small to run the motor as a synchronous motor.

#### **Torque - speed characteristics of Reluctance Motor:**

The torque speed characteristics are shown in below figure. The starting torque is highly dependent on the position of the rotor.

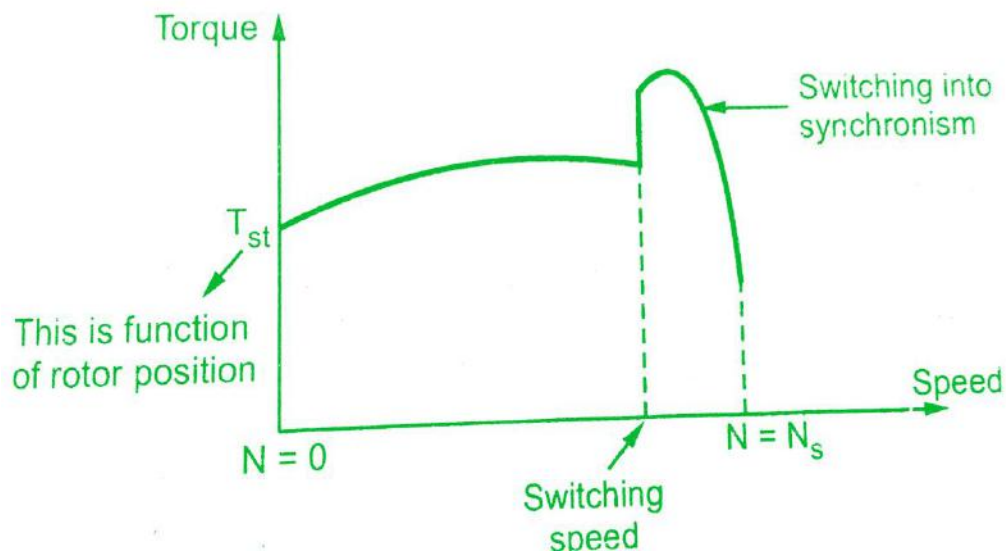

#### **Reluctance Motor Advantages:**

The **reluctance motor** has the following advantages,

- 1) No d.c. supply is necessary for the rotor.
- 2) Constant speed characteristics.
- 3) Robust construction.

4) Less maintenance.

**Reluctance Motor Disadvantages:**

The reluctance motor has following limitations,

- 1) Less efficiency
- 2) Poor power factor
- 3) Need of very low inertia rotor
- 4) Less capacity to drive the loads

**Applications of Reluctance Motor:**

Reluctance motor is used in

- Signalling Devices
- Control Apparatus
- Automatic regulators
- Recording Instruments
- Clocks
- All timing devices
- Teleprinters
- Gramophones

**STEPPER MOTOR**

The dc motor rotates continuously when it supplied by the DC source. The direction of rotation depends on the polarity of the supply. But the stepper motor rotations are not continuously. The rotor of this motor rotates in discrete steps.

The stepper motor is a special kind of motor which designed to rotate through a specific angle. There are two advantages to the stepper motor. The first one is that the stepper motor is compatible with digital systems and the second one is that, there is no need for any sensors for position and speed sensing.

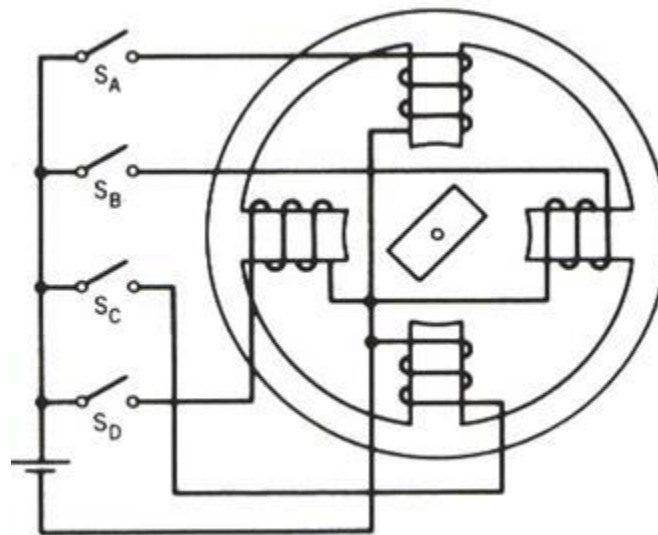

### **Working:**

The control circuit used to generate digital pulses. These digital pulses are given to the driver circuit. The driver circuit generates steps according to the pulses.

The number of steps generated by the driver circuit is the same as the number of steps generates by the control circuit.

The rotor rotates in the angular motion. Therefore, this step is known as the step angle. Step angle is nothing but the angular movement of the rotor when the control circuit generates one pulse. For example, the step angle is 15 degrees. So, if the control circuit generates one pulse, the motor rotates 15 degrees.

Stepper motors have multiple toothed electromagnets and it energized by the driver circuit. A gear-shaped piece of an iron place in the center of electromagnets.

When the electromagnets energized, it attracts the teeth of a gear. Hence, the gear's teeth are aligned to the first electromagnet. The next electromagnet placed at some angle. When the next electromagnet energized, it attracts the teeth of the gear and tries to align with the next electromagnet.

This is how the stepper motor rotates. According to the working principle, there are three types of the stepper motor.

### **Types of Stepper Motor: Stepper motors classified into three types;**

- Variable reluctance stepper motor
- Permanent magnet stepper
- Hybrid synchronous stepper

### **BRUSHLESS DC (BLDC) MOTOR**

A Brushless DC motor or BLDC motor is a type that is most suitable for applications that require high reliability, high efficiency, more torque per weight, etc. This article explains about BLDC motors in details.

#### **Construction of A BLDC Motor**

A commutator-brushes arrangement helps in achieving unidirectional torque in a typical dc motor. Obviously, commutator and brush arrangement is eliminated in a brushless dc motor. Here, an integrated inverter/switching circuit is used to achieve unidirectional torque. That is why these motors are, sometimes, also referred as 'electronically commutated motors'.

Just like any other electric motor, a BLDC motor also consists of two main parts a stator and a rotor. Permanent magnets are mounted on the rotor of a BLDC motor, and the stator is wound for a specific number of poles. Also, a control circuit is connected to the stator winding. Most of the times, the inverter/control circuit or controller is integrated into the stator assembly. This is the basic constructional difference between a brushless motor and a typical dc motor.

A typical controller provides a three-phase frequency-controlled supply to the stator winding. The supply is controlled by logical control circuits and energizes specific stator poles at a specific point of time. This can be understood from the below animations about working of BLDC motors.

#### **Types of BLDC Motors**

There are two types of BLDC motors based on their construction/design: (i) inner rotor design & (ii) outer rotor design. Regardless of these types, note that the permanent magnets are always mounted on the rotor and winding on the stator.

1. Inner rotor design (inrunner): this is a conventional design, where the rotor is located at the core (center) and stator winding surrounds it.

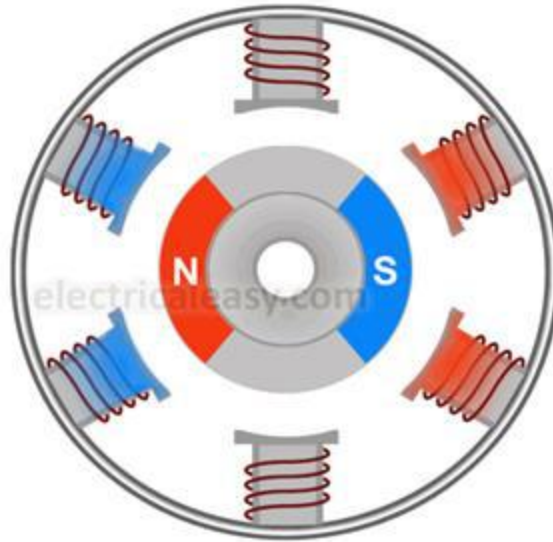

**Fig: Inner rotor BLDC motor working**

2. Outer rotor design (outrunner): In this configuration, the rotor is external. i.e. stator windings are located at the core while the rotor, carrying permanent magnets, surrounds the stator.

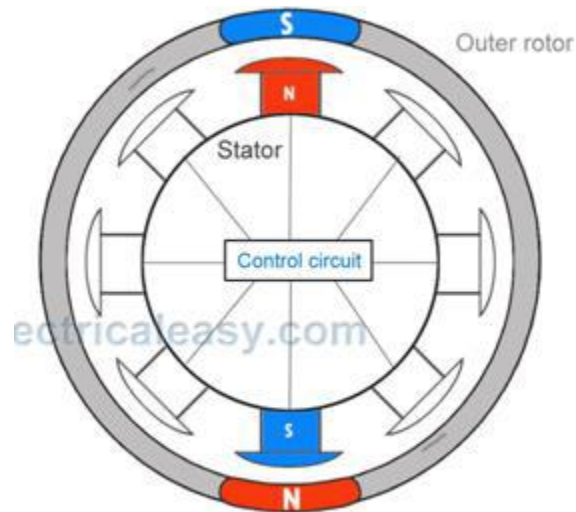

**Fig: Outer rotor BLDC motor working**

### **BLDC Motor Working:**

Stator windings of a BLDC motor are connected to a control circuit (an integrated switching circuit or inverter circuit). The control circuit energizes proper winding at the proper time, in a pattern which rotates around the stator. Permanent magnets on the rotor try to align with the energized electromagnets of the stator, and as soon as it aligns, the next electromagnets are energized. Thus, the rotor keeps running.

### **Advantages of BLDC Motors**

Since BLDC Motors are electronically commutated, there are several advantages over traditional Brushed DC Motors. Some of them are:

- No wear and tear (due to absence of brushes)
- High efficiency
- Better speed vs torque characteristics
- Long life
- Less noise or noiseless operation
- Significantly higher RPM

### **Disadvantages**

- Complex operation
- Requires maintenance
- A controller is required
- Costly
- Sensors are required

### **Applications of BLDC Motors**

BLDC motors fulfill many requirements that a brushed DC motor does. But as they require a complicated control circuit and due to cost considerations, they haven't yet completely replaced brushed DC motors, especially in low-cost applications. Despite this, there are many applications where BLDC motors dominate –

- **Consumer electronics** – computer hard drives, small cooling fans, cd/dvd players, etc. and also in modern appliances where quiet operation is desired – such as washing machines, air conditioners, etc.
- **Electric Vehicles** – many electric vehicles including electric and hybrid cars, electric bikes use BLDC motors.
- They have a wide range of applications in many other areas including robotics, industrial, motion control systems, etc.