

A Course Module

on

POWER ELECTRONICS

(20A02401T)

Prepared by

Mr.B.ANIL KUMAR

Asst.Professor

Department of EEE



SREE RAMA ENGINEERING COLLEGE

Approved by AICTE, New Delhi – Affiliated to JNTUA, Ananthapuramu

Accredited by NAAC with 'A' Grade

An ISO 9001:2015 & ISO 14001:2015 certified Institution

Rami Reddy Nagar, Karakambadi road, Tirupati-517507

SREE RAMA ENGINEERING COLLEGE

Course Code
20A02401T

POWER ELECTRONICS

L T P C
3 0 0 3

Semester IV

Course Objectives:

The student will be able to:

- Understand the differences between signal level and power level devices.
- Analyze controlled rectifier circuits.
- Analyze the operation of DC-DC choppers.
- Analyze the operation of voltage source inverters.

Course Outcomes (CO):

At the end of this course students will be able to:

- Understand the operation, characteristics and usage of basic Power Semiconductor Devices.
- Understand different types of Rectifier circuits with different operating conditions.
- Understand DC-DC converters operation and analysis of their characteristics.
- Understand the construction and operation of voltage source inverters, Voltage Controllers and Cyclo Converters.
- Apply all the above concepts to solve various numerical problem solving

UNIT - I Power Switching Devices

Diode, Thyristor, MOSFET, IGBT: I-V Characteristics; Firing circuit for thyristor; Voltage and current commutation of a thyristor; Gate drive circuits for MOSFET, IGBT and GTO. Introduction to Gallium Nitride and Silicon Carbide Devices.

UNIT - II Rectifiers

Single-phase half-wave and full-wave rectifiers, Single-phase full-bridge thyristor rectifier with R-load and highly inductive load; Three-phase full-bridge thyristor rectifier with R-load and highly inductive load; Input current wave shape, power factor and effect of source inductance; Analysis of rectifiers with filter capacitance, Dual Converter -Numerical problems.

UNIT - III DC-DC CONVERTERS

Elementary chopper with an active switch and diode, concepts of duty ratio, control strategies and average output voltage: Power circuit, analysis and waveforms at steady state, duty ratio control and average output voltage of Buck, Boost and Buck- Boost Converters.

UNIT - IV INVERTERS

Single phase Voltage Source inverters – operating principle - steady state analysis, Simple forced commutation circuits for bridge inverters – Mc Murray and Mc Murray Bedford inverters, Voltage control techniques for inverters and Pulse width modulation techniques, single phase current source inverter with ideal switches, basic series inverter, single phase parallel inverter – basic principle of operation only, Three phase bridge inverters (VSI) – 180 degree mode – 120 degree mode of operation - Numerical problems.

UNIT - V AC VOLTAGE CONTROLLERS & CYCLO CONVERTERS:

AC voltage controllers – Principle of phase control – Principle of integral cycle control - Single phase two SCRs in anti-parallel – With R and RL loads – modes of operation of Triac – Triac with R and RL loads – RMS load voltage, current and power factor - wave forms – Numerical problems.

Cyclo converters - Midpoint and Bridge connections - Single phase to single phase step-up and stepdown cyclo converters with Resistive and inductive load, Principle of operation, Waveforms, output voltage equation

Textbooks:

1. M. H. Rashid, "Power Electronics: Circuits, Devices and Applications", 2nd edition, Prentice Hall of India, 1998
2. P.S.Bimbhra,"Power Electronics", 4th Edition, Khanna Publishers, 2010.
3. M. D. Singh & K. B. Kanchandhani, "Power Electronics", Tata Mc Graw Hill Publishing Company, 1998.

Reference Books:

1. Ned Mohan, "Power Electronics", Wiley, 2011.
2. Robert W. Erickson and Dragan Maksimovic, "Fundamentals of Power Electronics" 2nd Edition, Kluwer Academic Publishers, 2004.
3. Vedam Subramanyam, "Power Electronics", New Age International (P) Limited, 1996.
4. V.R.Murthy, "Power Electronics", 1st Edition, Oxford University Press, 2005. 5. P.C.Sen, "Power Electronics", Tata Mc Graw-Hill Education, 1987.
5. "Power Electronic Control of Alternating Current Motors" by J.M.D.Murphy

Online Learning Resources:

<https://www.classcentral.com/course/youtube-electrical-power-electronics-47667/classroom>

https://onlinecourses.nptel.ac.in/noc21_ee01/preview

UNIT – I

Power Switching devices

Introduction to power electronics:

Power Electronics is a field which combines Power (electric power), Electronics and Control systems. Power engineering deals with the static and rotating power equipment for the generation, transmission and distribution of electric power. Electronics deals with the study of solid state semiconductor power devices and circuits for Power conversion to meet the desired control objectives (to control the output voltage and output power). Power electronics may be defined as the subject of applications of solid state power semiconductor devices (Thyristors) for the control and conversion of electric power. Power electronics deals with the study and design of Thyristorised power controllers for variety of application like Heat control, Light/Illumination control, Motor control - AC/DC motor drives used in industries, High voltage power supplies, Vehicle propulsion systems, High voltage direct current (HVDC) transmission.

Power Electronics refers to the process of controlling the flow of current and voltage and converting it to a form that is suitable for user loads. The most desirable power electronic system is one whose efficiency and reliability is 100%.

Take a look at the following block diagram. It shows the components of a Power Electronic system and how they are interlinked.

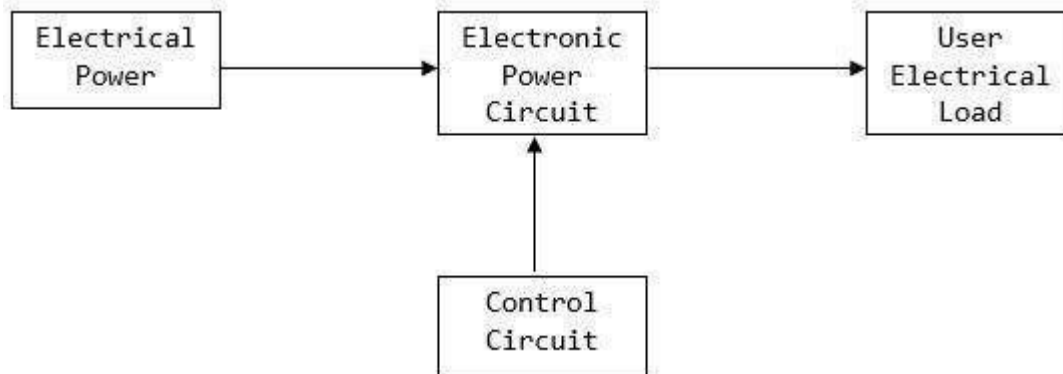

Figure: 1.1. Block diagram of DC power supply

A power electronic system converts electrical energy from one form to another and ensures the following is achieved –

- Maximum efficiency
- Maximum reliability
- Maximum availability
- Minimum cost
- Least weight
- Small size

Applications of Power Electronics are classified into two types – Static Applications and Drive Applications.

Static Applications

This utilizes moving and/or rotating mechanical parts such as welding, heating, cooling, and electroplating and DC power.

DC Power Supply

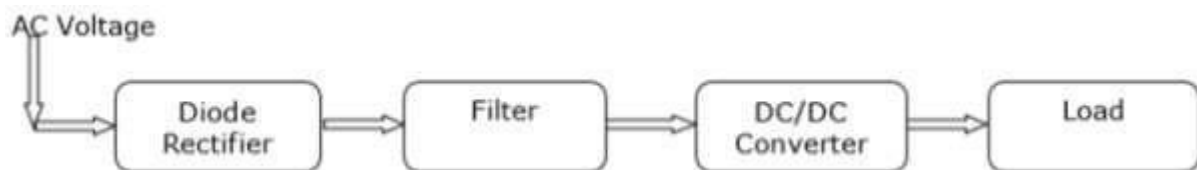

Figure: 1.2. Block diagram of DC power supply

Drive Applications

Drive applications have rotating parts such as motors. Examples include compressors, pumps, conveyer belts and air conditioning systems.

Air Conditioning System

Power electronics is extensively used in air conditioners to control elements such as compressors. A schematic diagram that shows how power electronics is used in air conditioners is shown below.

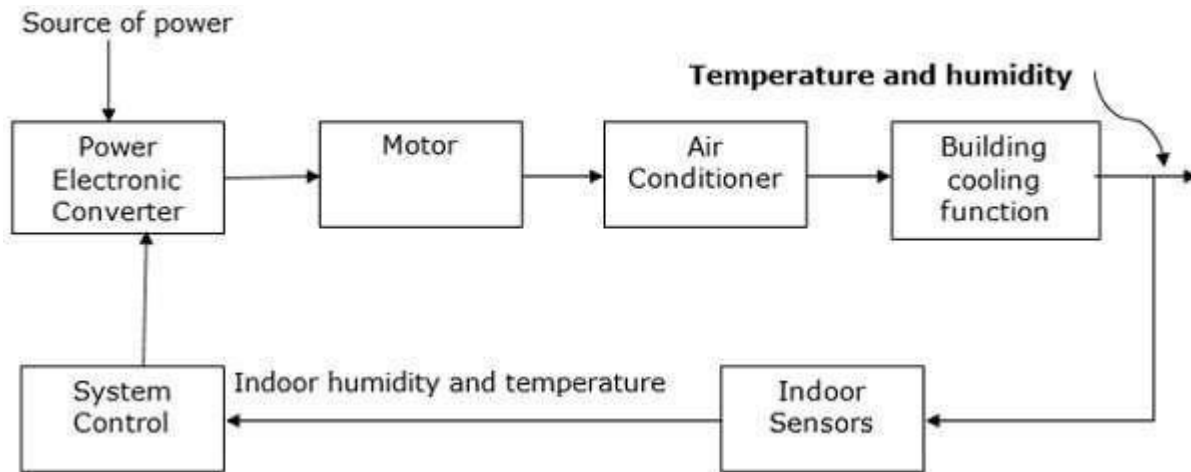

Figure: 1.3. Block diagram of Air Conditioning System

Power electronic applications

Commercial applications Heating Systems Ventilating, Air Conditioners, Central Refrigeration, Lighting, Computers and Office equipments, Uninterruptible Power Supplies (UPS), Elevators, and Emergency Lamps

Domestic applications Cooking Equipments, Lighting, Heating, Air Conditioners, Refrigerators & Freezers, Personal Computers, Entertainment Equipments, UPS

Industrial applications Pumps, compressors, blowers and fans Machine tools, arc furnaces, induction furnaces, lighting control circuits, industrial lasers, induction heating, welding equipments

Aerospace applications Space shuttle power supply systems, satellite power systems, aircraft power systems.

Telecommunications Battery chargers, power supplies (DC and UPS), mobile cell phone battery chargers

Transportation Traction control of electric vehicles, battery chargers for electric vehicles, electric locomotives, street cars, trolley buses, automobile electronics including engine controls

Utility systems High voltage DC transmission (HVDC), static VAR compensation (SVC), Alternative energy sources (wind, photovoltaic), fuel cells, energy storage systems, induced draft fans and boiler feed water pumps

Types of power electronic converters

1. Rectifiers (AC to DC converters): These converters convert constant ac voltage to variable dc output voltage.
2. Choppers (DC to DC converters): Dc chopper converts fixed dc voltage to a controllable dc output voltage.
3. Inverters (DC to AC converters): An inverter converts fixed dc voltage to a variable ac output voltage.
4. AC voltage controllers: These converters converts fixed ac voltage to a variable ac output voltage at same frequency.
5. Cycloconverters: These circuits convert input power at one frequency to output power at a different frequency through one stage conversion.

Power semiconductor devices

- i. Power Diodes.
- ii. Power transistors (BJT's).
- iii. Power MOSFETS.
- iv. IGBT's.
- v. Thyristors

Thyristors are a family of p-n-p-n structured power semiconductor switching devices

Power diodes

Power diodes are made of silicon p-n junction with two terminals, anode and cathode. P-N junction is formed by alloying, diffusion and epitaxial growth. Modern techniques in diffusion and epitaxial processes permit desired device characteristics. The diodes have the following advantages High mechanical and thermal reliability High peak inverse voltage Low reverse current Low forward voltage drop High efficiency Compactness.

Power transistors

Power transistors are devices that have controlled turn-on and turn-off characteristics. These devices are used as switching devices and are operated in the saturation region resulting in low on-state voltage drop. They are turned on when a current signal is given to base or control terminal. The transistor remains on so long as the control signal is present. The switching speed of modern transistors is much higher than that of thyristors and is used extensively in dc-dc and dc-ac converters. However their

voltage and current ratings are lower than those of thyristors and are therefore used in low to medium power applications. Power transistors are classified as follows

- o Bipolar junction transistors(BJT's)
- o Metal-oxide semiconductor field-effect transistors(MOSFET's)
- o Static Induction transistors(SIT's)
- o Insulated-gate bipolar transistors(IGBT's)

Advantages of BJT'S

- i. BJT's have high switching frequencies since their turn-on and turn-off time are low.
- ii. The turn-on losses of a BJT are small.
- iii. BJT has controlled turn-on and turn-off characteristics since base drive control is possible.
- iv. BJT does not require commutation circuits

Demerits of BJT

- i. Drive circuit of BJT is complex.
- ii. It has the problem of charge storage which sets a limit on switching frequencies.
- iii. It cannot be used in parallel operation due to problems of negative temperature coefficient.

Thyristors – Silicon Controlled Rectifiers (SCR's)

A silicon controlled rectifier or semiconductor-controlled rectifier is a four-layer solidstate current-controlling device. The name "silicon controlled rectifier" is General Electric's trade name for a type of thyristor.

SCRs are mainly used in electronic devices that require control of high voltage and power. This makes them applicable in medium and high AC power operations such as motor control function.

An SCR conducts when a gate pulse is applied to it, just like a diode. It has four layers of semiconductors that form two structures namely; NPNP or PNP. In addition, it has three junctions labeled as J1, J2 and J3 and three terminals(anode, cathode and a gate). An SCR is diagrammatically represented as shown below.

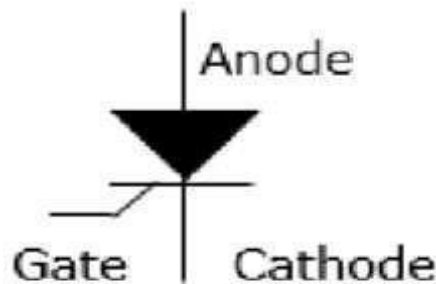

Figure: 1.4. Symbol of thyristor

The anode connects to the P-type, cathode to the N-type and the gate to the P-type as shown below.

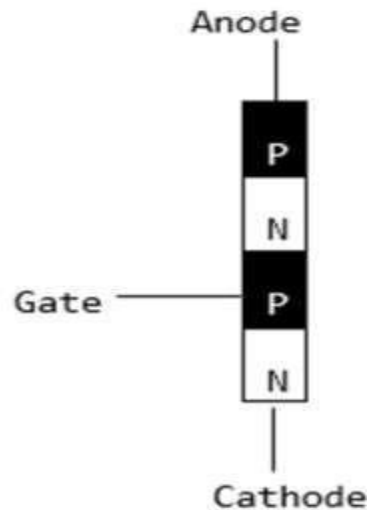

Figure: 1.5. Structure of thyristor

In an SCR, the intrinsic semiconductor is silicon to which the required dopants are infused. However, doping a PNPJunction is dependent on the SCR application.

Modes of Operation in SCR

- OFF state (forward blocking mode) – Here the anode is assigned a positive voltage, the gate is assigned a zero voltage (disconnected) and the cathode is assigned a negative voltage. As a result, Junctions J1 and J3 are in forward bias while J2 is in reverse bias. J2 reaches its breakdown avalanche value and starts to conduct. Below this value, the resistance of J1 is significantly high and is thus said to be in the off state.
- ON state (conducting mode) – An SCR is brought to this state either by increasing the potential difference between the anode and cathode above the avalanche voltage or by applying a positive signal at the gate. Immediately the SCR starts to conduct, gate voltage is no longer needed to maintain the ON state and is, therefore, switched off by –
 - Decreasing the current flow through it to the lowest value called holding current
 - Using a transistor placed across the junction.
- Reverse blocking – This compensates the drop in forward voltage. This is due to the fact that a low doped region in P1 is needed. It is important to note that the voltage ratings of forward and reverse blocking are equal.

Characteristics of Thyristor

A thyristor is a four layer 3 junction p-n-p-n semiconductor device consisting of at least three p-n junctions, functioning as an electrical switch for high power operations. It has three basic terminals, namely the anode, cathode and the gate mounted on the semiconductor layers of the device. The symbolic diagram and the basic circuit diagram for determining the characteristics of thyristor is shown in the figure below,

V-I Characteristics of a Thyristor

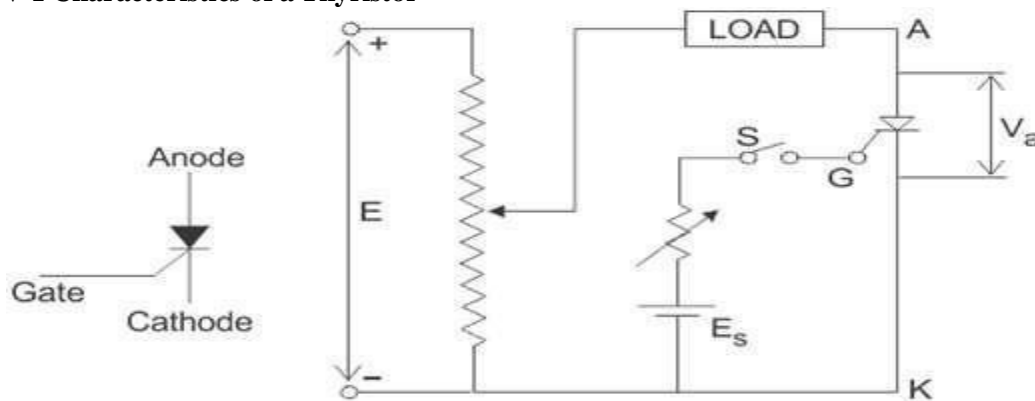

Figure: 1.6. Circuit diagram for characteristics of SCR

From the circuit diagram above we can see the anode and cathode are connected to the supply voltage through the load. Another secondary supply E_s is applied between the gate and the cathode terminal which supplies for the positive gate current when the switch S is closed. On giving the supply we get the required V-I characteristics of a thyristor show in the figure below for anode to cathode voltage V_a and anode current I_a as we can see from the circuit diagram. A detailed study of the characteristics reveal that the thyristor has three basic modes of operation, namely the reverse blocking mode, forward blocking (off-state) mode and forward conduction (on-state) mode. Which are discussed in great details below, to understand the overall characteristics of a thyristor.

Reverse Blocking Mode of Thyristor

Initially for the reverse blocking mode of the thyristor, the cathode is made positive with respect to anode by supplying voltage E and the gate to cathode supply voltage E_s is detached initially by keeping switch S open. For understanding this mode we should look into the fourth quadrant where the thyristor is reverse biased.

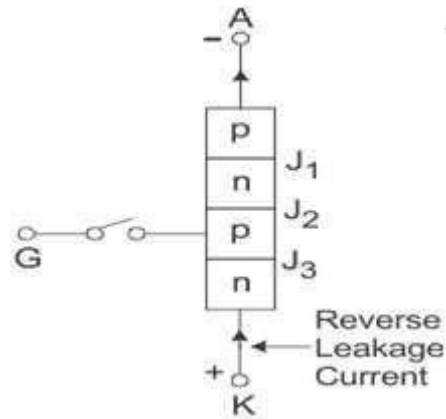

Figure: 1.7. Reverse blocking mode of SCR

Here Junctions J_1 and J_3 are reverse biased whereas the junction J_2 is forward biased. The behavior of the thyristor here is similar to that of two diodes are connected in series with reverse voltage applied across them. As a result only a small leakage current of the order of a few μAmps flows. This is the reverse blocking mode or the off-state, of the thyristor. If the reverse voltage is now increased, then at a particular voltage, known as the critical breakdown voltage V_{BR} , an avalanche occurs at J_1 and J_3 and the reverse current increases rapidly. A large current associated with V_{BR} gives rise to more losses in the SCR, which results in heating. This may lead to thyristor damage as the junction temperature may exceed its permissible temperature rise. It should, therefore, be ensured that maximum working reverse voltage across a thyristor does not exceed V_{BR} . When reverse voltage applied across a thyristor is less than V_{BR} , the device offers very high impedance in the reverse direction. The SCR in the reverse blocking mode may therefore be treated as open circuit.

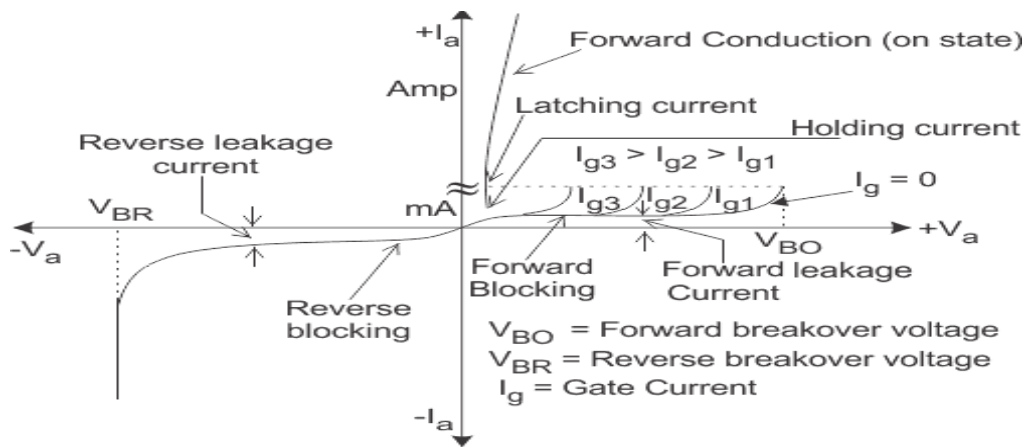

Figure: 1.8. V- I characteristics of SCR

Forward Blocking Mode Now considering the anode is positive with respect to the cathode, with gate kept in open condition. The thyristor is now said to be forward biased as shown the figure below.

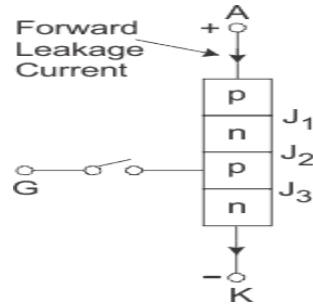

Figure: 1.9. Forward connection of SCR

As we can see the junctions J_1 and J_3 are now forward biased but junction J_2 goes into reverse biased condition. In this particular mode, a small current, called forward leakage current is allowed to flow initially as shown in the diagram for characteristics of thyristor. Now, if we keep on increasing the forward biased anode to cathode voltage.

In this particular mode, the thyristor conducts currents from anode to cathode with a very small voltage drop across it. A thyristor is brought from forward blocking mode to forward conduction mode by turning it on by exceeding the forward break over voltage or by applying a gate pulse between gate and cathode. In this mode, thyristor is in on-state and behaves like a closed switch. Voltage drop across thyristor in the on state is of the order of 1 to 2 V depending beyond a certain point, then the reverse biased junction J_2 will have an avalanche breakdown at a voltage called forward break over voltage V_{BO} of the thyristor. But, if we keep the forward voltage less than V_{BO} , we can see from the characteristics of thyristor, that the device offers high impedance. Thus even here the thyristor operates as an open switch during the forward blocking mode.

Forward Conduction Mode

When the anode to cathode forward voltage is increased, with gate circuit open, the reverse junction J_2 will have an avalanche breakdown at forward break over voltage V_{BO} leading to thyristor turn on. Once the thyristor is turned on we can see from the diagram for characteristics of thyristor, that the point M at once shifts toward N and then anywhere between N and K. Here NK represents the forward conduction mode of the thyristor. In this mode of operation, the thyristor conducts maximum current with minimum

voltage drop, this is known as the forward conduction or the turn on mode of the thyristor.

Two transistor analogy of SCR

Basic **operating principle of SCR**, can be easily understood by the **two transistor model of SCR** or analogy of silicon controlled rectifier, as it is also a combination of P and N layers, shown in figure below

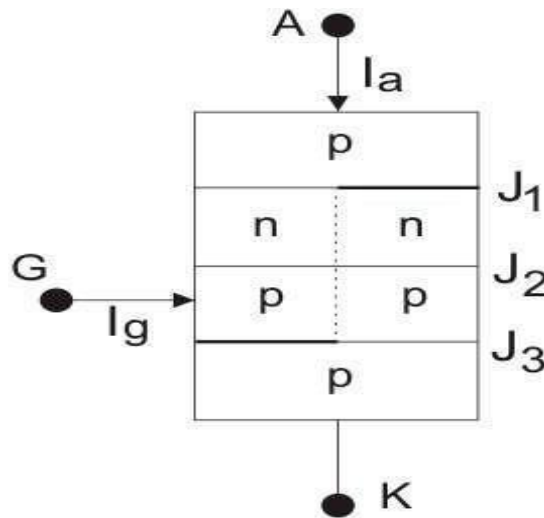

Figure: 1.10. Two transistor structure of SCR

This is a pnpn thyristor. If we bisect it through the dotted line then we will get two transistors i.e. one pnp transistor with J₁ and J₂ junctions and another is with J₂ and J₃ junctions as shown in figure below.

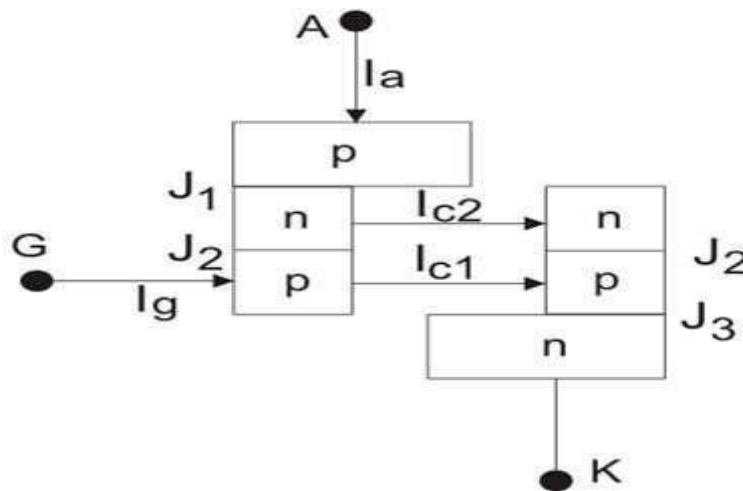

Figure: 1.11. Two transistor structure of SCR

When the transistors are in off state, the relation between the collector current and emitter current is shown below

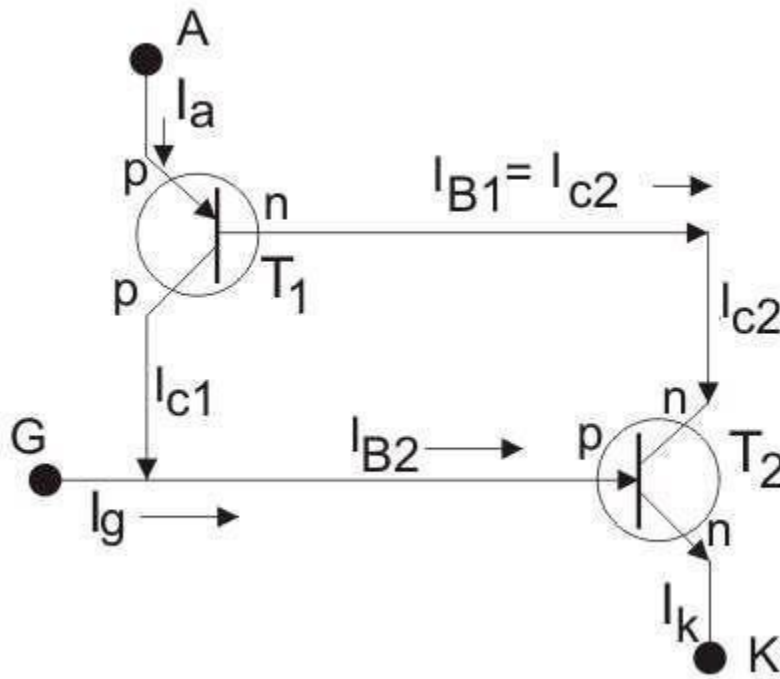

Figure: 1. 12. Two transistors connection of SCR

Here, I_C is collector current, I_E is emitter current, I_{CBO} is forward leakage current, α is common base forward current gain and relationship between I_C and I_B is $I_C = \beta I_B$ Where, I_B is base current and β is common emitter forward current gain. Let's for transistor T_1 this relation holds

$$I_{C1} = \alpha_1 I_a + I_{CBO1} \dots (i)$$

And that for transistor T_2

$I_{C2} = \alpha_2 I_k + I_{CBO2} \dots (ii)$ again $I_{C2} = \beta_2 I_{B2}$ Now, by the analysis of two transistors model we can get anode current,

$$I_a = I_{C1} + I_{C2} \text{ [applying KCL]}$$

From equation (i) and (ii), we get, $I_a = \alpha_1 I_a + I_{CBO1} + \alpha_2 I_k + I_{CBO2} \dots (iii)$

If applied gate current is I_g then cathode current will be the summation of anode current and gate current

$$\text{i.e. } I_k = I_a + I_g$$

By substituting this value of I_k in (iii) we get,

$$I_a = \alpha_1 I_a + I_{CBO1} + \alpha_2 (I_a + I_g) + I_{CBO2}$$

$$I_a = \frac{\alpha_2 I_g + I_{CBO1} + I_{CBO2}}{1 - (\alpha_1 + \alpha_2)}$$

From this relation we can assure that with increasing the value of $(\alpha_1 + \alpha_2)$ towards unity, corresponding anode current will increase. Now the question is how $(\alpha_1 + \alpha_2)$ increasing. Here is the explanation using **two transistor model of SCR**. At the first stage when we apply a gate current I_g , it acts as base current of T_2 transistor i.e. $I_{B2} = I_g$ and emitter current i.e. $I_k = I_g$ of the T_{2} transistor. Hence establishment of the emitter current gives rise α_2 as

$$\alpha_2 = \frac{I_{CBO1}}{I_g}$$

Presence of base current will generate collector current as

$$I_{C2} = \beta_2 \times I_{B2} = \beta_2 I_g$$

This I_{C2} is nothing but base current I_{B1} of transistor T_{1} , which will cause the flow of collector current,

$$I_{C2} = \beta_1 \times I_{B1} = \beta_1 \beta_2 I_g$$

I_{C1} and I_{B1} lead to increase I_{C1} as

$$I_a = I_{C1} + I_{B1}$$

And hence, α_1 increases. Now, new base current of T_2 is

$$I_g + I_{C1} = (1 + \beta_1 \beta_2) I_g,$$

This will lead to increase emitter current

$$I_k = I_g + I_{C1}$$

and as a result α_2 also increases and this further increases

$$I_{C2} = \beta_2(1 + \beta_1\beta_2)I_g.$$

As

$$I_{B1} = I_{C2},$$

α_1 again increases. This continuous positive feedback effect increases $(\alpha_1 + \alpha_2)$ towards unity and anode current tends to flow at a very large value. The value current then can only be controlled by external resistance of the circuit.

Turn on methods of SCR

The turning on Process of the SCR is known as Triggering. In other words, turning the SCR from Forward-Blocking state to Forward-Conduction state is known as Triggering. The various methods of SCR triggering are discussed here.

The various SCR triggering methods are

- Forward Voltage Triggering
- Thermal or Temperature Triggering
- Radiation or Light triggering
- dv/dt Triggering
- Gate Triggering

(a) Forward Voltage Triggering:-

- In this mode, an additional forward voltage is applied between anode and cathode.
- When the anode terminal is positive with respect to cathode (V_{AK}), Junction J1 and J3 is forward biased and junction J2 is reverse biased.
- No current flow due to depletion region in J2 is reverse biased (except leakage current).
- As V_{AK} is further increased, at a voltage V_{BO} (Forward Break Over Voltage) the junction J2 undergoes avalanche breakdown and so a current flows and the device tends to turn ON (even when gate is open)

(b) Thermal (or) Temperature Triggering:-

- The width of depletion layer of SCR decreases with increase in junction temperature.
- Therefore in SCR when V_{AR} is very near its breakdown voltage, the device is triggered by increasing the junction temperature.
- By increasing the junction temperature the reverse biased junction collapses thus the device starts to conduct.

(c) Radiation Triggering (or) Light Triggering:-

- For light triggered SCRs a special terminal niche is made inside the inner P layer instead of gate terminal.
- When light is allowed to strike this terminal, free charge carriers are generated.
- When intensity of light becomes more than a normal value, the thyristor starts conducting.
- This type of SCRs are called as LASCR

(d) dv/dt Triggering:-

- When the device is forward biased, J1 and J3 are forward biased, J2 is reverse biased.
- Junction J2 behaves as a capacitor, due to the charges existing across the junction.
- If voltage across the device is V, the charge by Q and capacitance by C then,

$$i_c = dQ/dt$$

$$Q = CV$$

$$i_c = d(CV)/dt$$

$$= CdV/dt + VdC/dt$$

$$\text{as } dC/dt = 0$$

$$i_c = CdV/dt$$

- Therefore when the rate of change of voltage across the device becomes large, the device may turn ON, even if the voltage across the device is small.

(e) Gate Triggering:-

- This is most widely used SCR triggering method.
- Applying a positive voltage between gate and cathode can Turn ON a forward biased thyristor.
- When a positive voltage is applied at the gate terminal, charge carriers are injected in the inner P-layer, thereby reducing the depletion layer thickness.
- As the applied voltage increases, the carrier injection increases, therefore the voltage at which forward break-over occurs decreases.

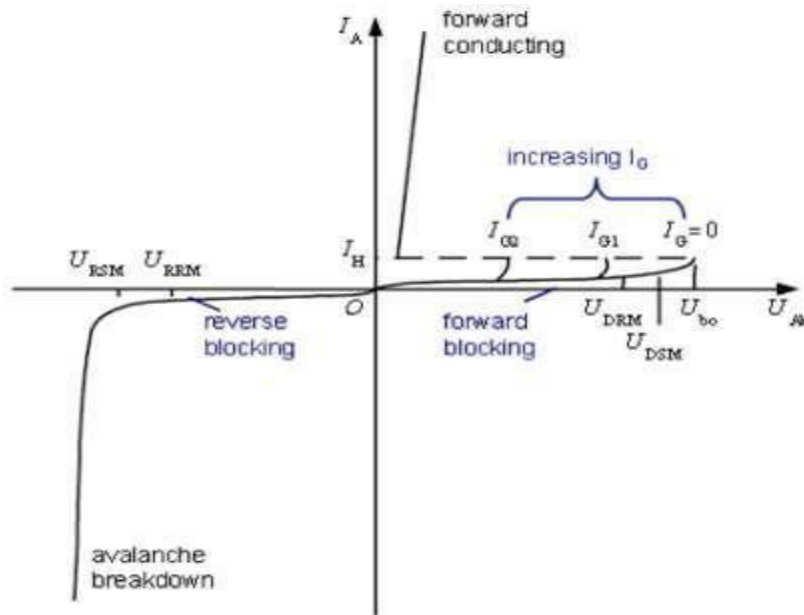

Figure: 1. 13. V - I characteristics of SCR

- Three types of signals are used for gate triggering.

1. DC gate triggering:-

- A DC voltage of proper polarity is applied between gate and cathode (Gate terminal is positive with respect to Cathode).
- When applied voltage is sufficient to produce the required gate Current, the device starts conducting.
- One drawback of this scheme is that both power and control circuits are DC and there is no isolation between the two.
- Another disadvantage is that a continuous DC signal has to be applied. So gate power loss is high.

2. AC Gate Triggering:-

- Here AC source is used for gate signals.
- This scheme provides proper isolation between power and control circuit.
- Drawback of this scheme is that a separate transformer is required to step down ac supply.
- There are two methods of AC voltage triggering namely (i) R Triggering (ii) RC triggering

(i) Resistance triggering:

The following circuit shows the resistance triggering.

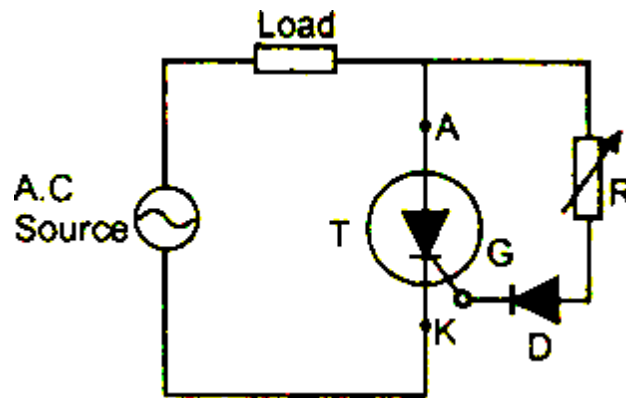

Figure: 1. 14. Resistance triggering circuit of SCR

- In this method, the variable resistance R is used to control the gate current.
- Depending upon the value of R, when the magnitude of the gate current reaches the sufficient value (latching current of the device) the SCR starts to conduct.
- The diode D is called as blocking diode. It prevents the gate cathode junction from getting damaged in the negative half cycle.
- By considering that the gate circuit is purely resistive, the gate current is in phase with the applied voltage.
- By using this method we can achieve maximum firing angle up to 90° .

(ii) RC Triggering

The following circuit shows the resistance-capacitance triggering.

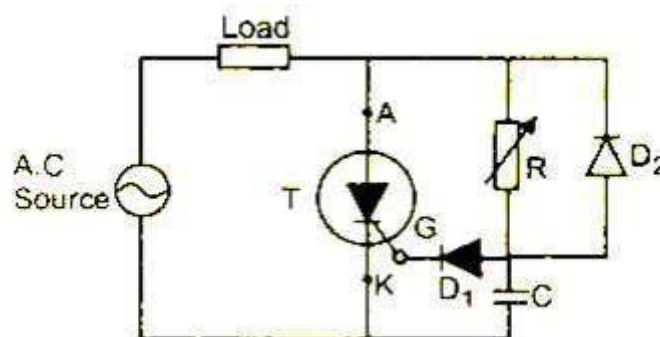

Figure: 1. 15. Resistance Capacitance triggering circuit of SCR

- By using this method we can achieve firing angle more than 90° .
- In the positive half cycle, the capacitor is charged through the variable resistance R up to the peak value of the applied voltage.
- The variable resistor R controls the charging time of the capacitor.
- Depends upon the voltage across the capacitor, when sufficient amount of gate current will flow in the circuit, the SCR starts to conduct.
- In the negative half cycle, the capacitor C is charged up to the negative peak value through the diode D2.
- Diode D1 is used to prevent the reverse break down of the gate cathode junction in the negative half cycle.

3. Pulse Gate Triggering:-

- In this method the gate drive consists of a single pulse appearing periodically (or) a sequence of high frequency pulses.
- This is known as carrier frequency gating.
- A pulse transformer is used for isolation.
- The main advantage is that there is no need of applying continuous signals, so the gate losses are reduced.

Advantages of pulse train triggering:

- Low gate dissipation at higher gate current.
- Small gate isolating pulse transformer
- Low dissipation in reverse biased condition is possible. So simple trigger circuits are possible in some cases
- When the first trigger pulse fails to trigger the SCR, the following pulses can succeed in latching SCR. This important while
- Triggering inductive circuits and circuits having back emf's.

Turn off methods of SCR:

SCR can be turned ON by applying appropriate positive gate voltage between the gate and cathode terminals, but it cannot be turned OFF through the gate terminal. The SCR can be brought back to the

forward blocking state from the forward conduction state by reducing the anode or forward current below the holding current level.

The turn OFF process of an SCR is called **commutation**. The term commutation means the transfer of currents from one path to another. So the commutation circuit does this job by reducing the forward current to zero so as to turn OFF the SCR or Thyristor.

To turn OFF the conducting SCR the below conditions must be satisfied.

- The anode or forward current of SCR must be reduced to zero or below the level of holding current and then,
- A sufficient reverse voltage must be applied across the SCR to regain its forward blocking state.

When the SCR is turned OFF by reducing forward current to zero there exist excess charge carriers in different layers. To regain the forward blocking state of an SCR, these excess carriers must be recombined. Therefore, this recombination process is accelerated by applying a reverse voltage across the SCR.

SCR Turn OFF Methods

The reverse voltage which causes to commutate the SCR is called commutation voltage. Depending on the commutation voltage located, the commutation methods are classified into two major types.

Those are 1) Forced commutation and 2) Natural commutation. Let us discuss in brief about these methods.

Forced Commutation

In case of DC circuits, there is no natural current zero to turn OFF the SCR. In such circuits, forward current must be forced to zero with an external circuit to commutate the SCR hence named as forced commutation.

This commutating circuit consists of components like inductors and capacitors called as commutating components. These commutating components cause to apply a reverse voltage across the SCR that immediately bring the current in the SCR to zero.

Based on the manner in which the zero current achieved and arrangement of the commutating components, forced commutation is classified into different types such as class A, B, C, D, and E. This commutation is mainly used in chopper and inverter circuits.

Class A Commutation

This is also known as self commutation, or resonant commutation, or load commutation. In this commutation, the source of commutation voltage is in the load. This load must be an under damped R-L- C supplied with a DC supply so that natural zero is obtained.

The commutating components L and C are connected either parallel or series with the load resistance R as shown below with waveforms of SCR current, voltage and capacitor voltage.

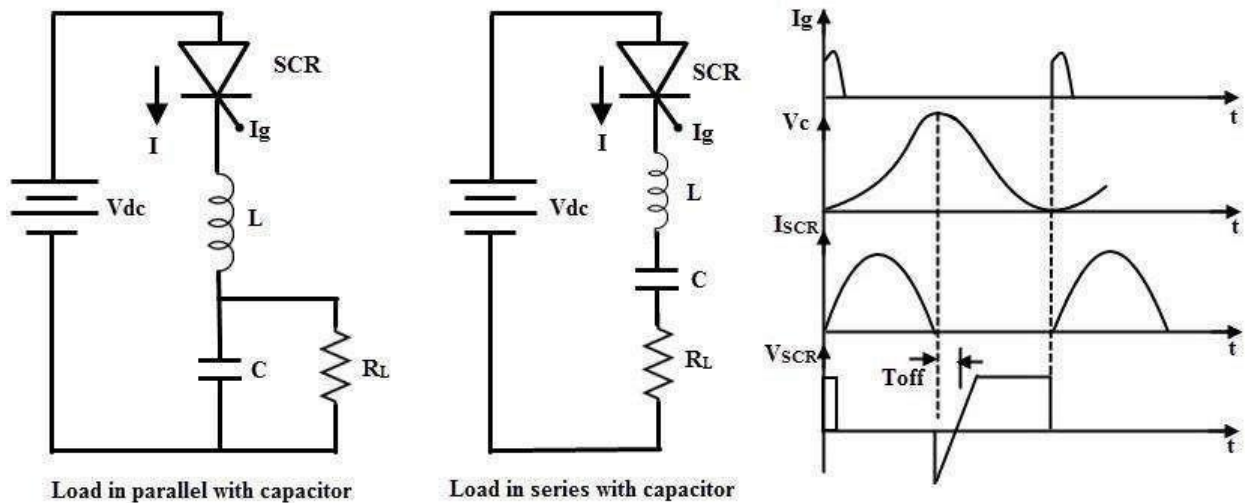

Figure: 1. 16. Class A Commutation circuit and waveforms

The value of load resistance and commutating components are so selected that they forms a under damped resonant circuit to produce natural zero. When the thyristor or SCR is triggered, the forward currents starts flowing through it and during this the capacitor is charged up to the value of E .

Once the capacitor is fully charged (more than the supply source voltage) the SCR becomes reverse biased and hence the commutation of the device. The capacitor discharges through the load resistance to make ready the circuit for the next cycle of operation. The time for switching OFF the SCR depends on the resonant frequency which further depends on the L and C components.

This method is simple and reliable. For high frequency operation which is in the range above 1000 Hz, this type of commutation circuits is preferred due to the high values of L and C components.

Class B Commutation

This is also a self commutation circuit in which commutation of SCR is achieved automatically by L and C components, once the SCR is turned ON. In this, the LC resonant circuit is connected across the SCR but not in series with load as in case of class A commutation and hence the L and C components do not carry the load current.

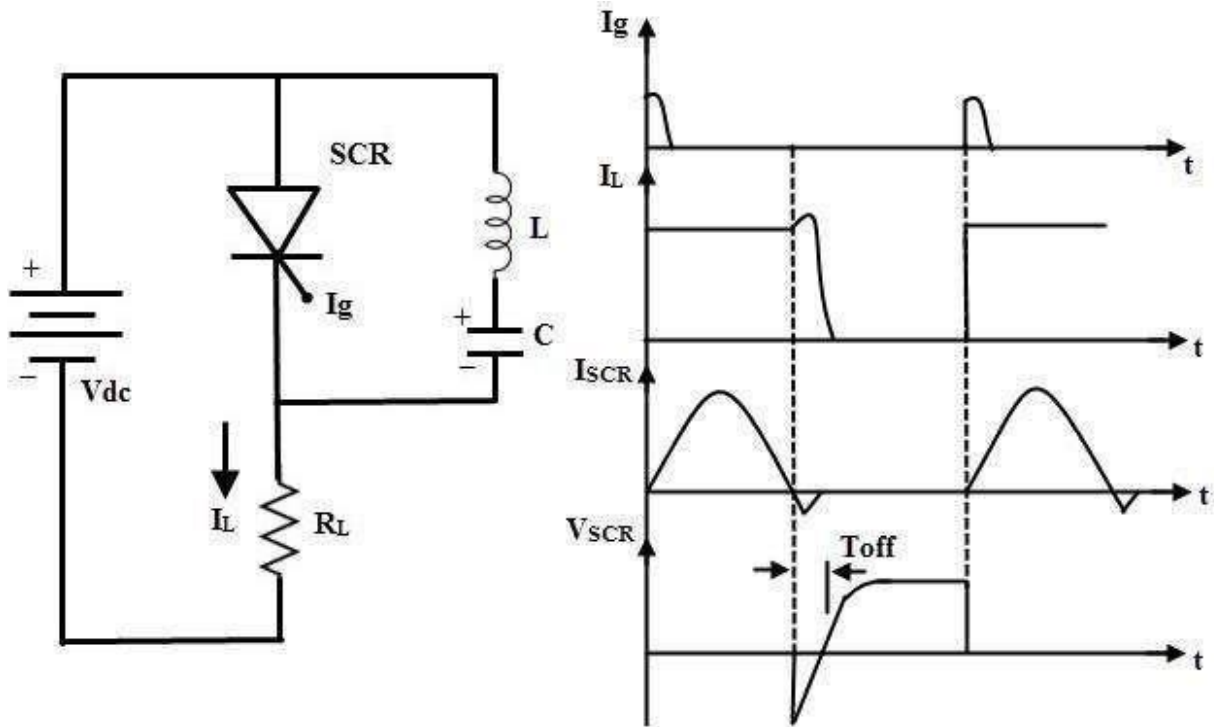

Figure: 1. 17. Class B Commutation circuit and waveforms

When the DC supply is applied to the circuit, the capacitor charges with an upper plate positive and lower plate negative up to the supply voltage E. When the SCR is triggered, the current flows in two directions, one is through $E+ - SCR - R - E-$ and another one is the commutating current through L and C components.

Once the SCR is turned ON, the capacitor starts discharging through $C+ - L - T - C-$. When the capacitor is fully discharged, it starts charging with a reverse polarity. Hence a reverse voltage is applied across the SCR which causes the commutating current I_C to oppose load current I_L .

When the commutating current I_c is higher than the load current, the SCR will automatically turn OFF and the capacitor charges with original polarity.

In the above process, the SCR is turned ON for some time and then automatically turned OFF for some time. This is a continuous process and the desired frequency of ON/OFF depends on the values of L and C. This type of commutation is mostly used in chopper circuits.

Class C Commutation

In this commutation method, the main SCR is to be commutated is connected in series with the load and an additional or complementary SCR is connected in parallel with main SCR. This method is also called as complementary commutation.

In this , SCR turns OFF with a reverse voltage of a charged capacitor. The figure below shows the complementary commutation with appropriate waveforms.

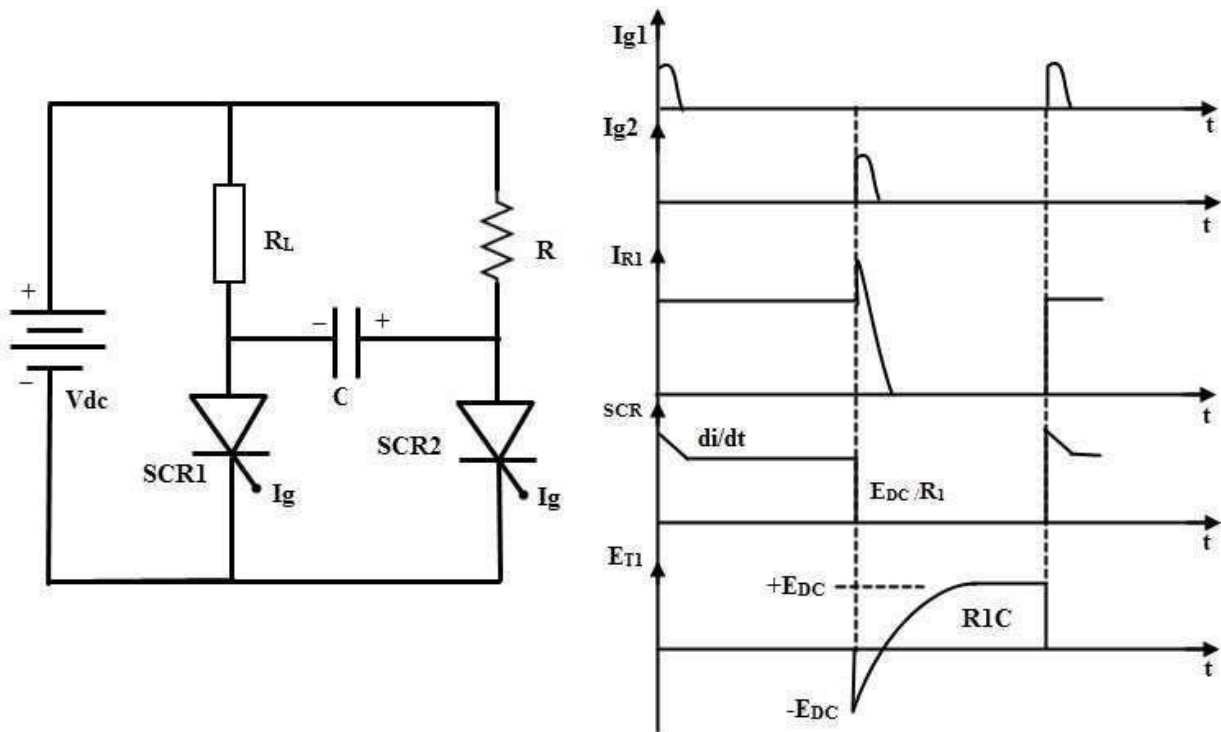

Figure: 1. 18. Class C Commutation circuit and waveforms

Initially, both SCRs are in OFF state so the capacitor voltage is also zero. When the SCR1 or main SCR is triggered, current starts flowing in two directions, one path is $E^+ - R1 - SCR1 - E^-$ and another path is the charging current $E^+ - R2 - C^+ - C^- - SCR1 - E^-$. Therefore, the capacitor starts charging up to the value of E .

When the SCR2 is triggered, SCR1 is turned ON and simultaneously a negative polarity is applied across the SCR1. So this reverse voltage across the SCR1 immediately causes to turn OFF the SCR1. Now the capacitor starts charging with a reverse polarity through the path of $E+ - R1 - C+ - C- - SCR2 - E-$. And again, if the SCR1 is triggered, discharging current of the capacitor turns OFF the SCR2.

This commutation is mainly used in single phase inverters with a centre tapped transformers. The Mc Murray Bedford inverter is the best example of this commutation circuit. This is a very reliable method of commutation and it is also useful even at frequencies below 1000Hz.

Class D Commutation

This is also called as auxiliary commutation because it uses an auxiliary SCR to switch the charged capacitor. In this, the main SCR is commutated by the auxiliary SCR. The main SCR with load resistance forms the power circuit while the diode D, inductor L and SCR2 forms the commutation circuit.

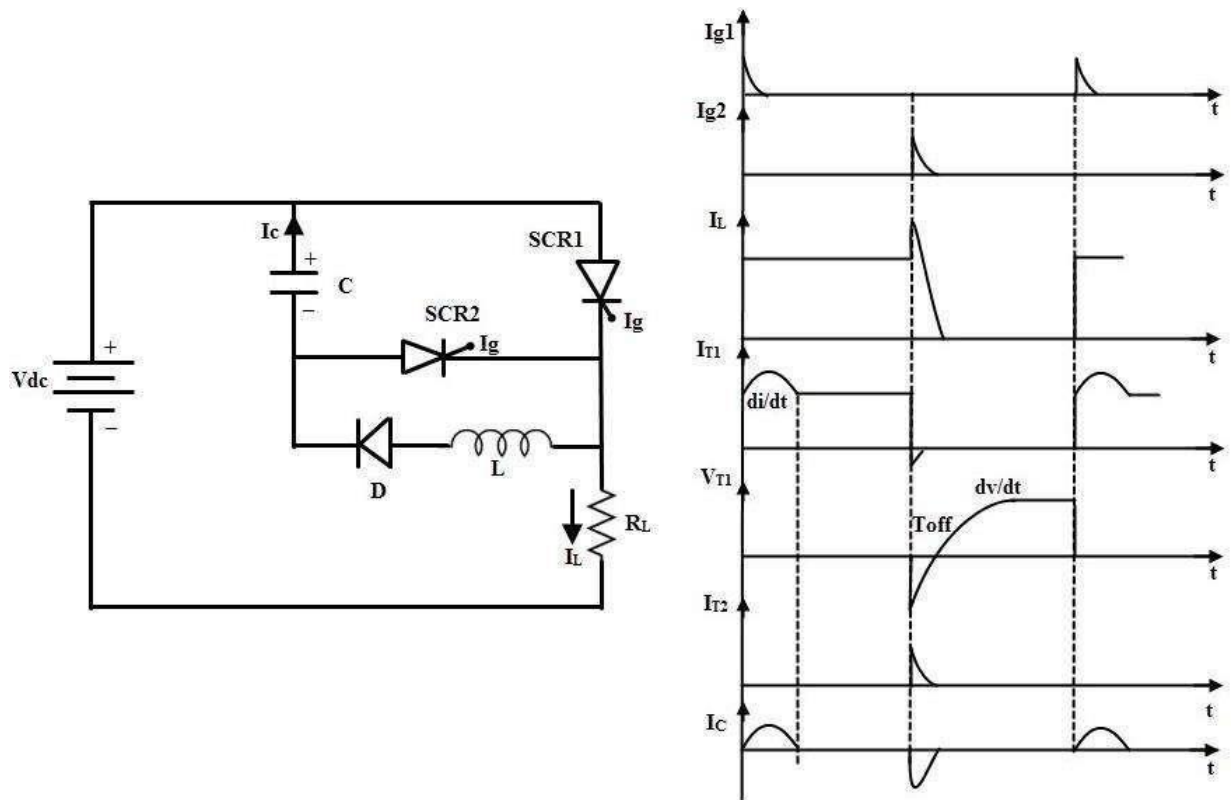

Figure: 1. 19. Class D Commutation circuit and waveforms

When the supply voltage E is applied, both SCRs are in OFF state and hence the capacitor voltage is zero. In order to charge the capacitor, SCR2 must be triggered first. So the capacitor charges through the path $E+ - C+ - C- - SCR2 - R - E-$.

When the capacitor is fully charged the SCR2 becomes turned OFF because no current flow through the SCR2 when capacitor is charged fully. If the SCR1 is triggered, the current flows in two directions; one is the load current path $E+ - SCR1 - R - E-$ and another one is commutation current path $C+ - SCR1 - L - D - C$.

As soon as the capacitor completely discharges, its polarities will be reversed but due to the presence of diode the reverse discharge is not possible. When the SCR2 is triggered capacitor starts discharging through $C+ - SCR2 - SCR1 - C-$. When this discharging current is more than the load current the SCR1 becomes turned OFF.

Again, the capacitor starts charging through the SCR2 to a supply voltage E and then the SCR2 is turned OFF. Therefore, both SCRs are turned OFF and the above cyclic process is repeated. This commutation method is mainly used in inverters and also used in the Jones chopper circuit.

Class E Commutation

This is also known as external pulse commutation. In this, an external pulse source is used to produce the reverse voltage across the SCR. The circuit below shows the class E commutation circuit which uses a pulse transformer to produce the commutating pulse and is designed with tight coupling between the primary and secondary with a small air gap.

If the SCR need to be commutated, pulse duration equal to the turn OFF time of the SCR is applied. When the SCR is triggered, load current flows through the pulse transformer. If the pulse is applied to the primary of the pulse transformer, an emf or voltage is induced in the secondary of the pulse transformer.

This induced voltage is applied across the SCR as a reverse polarity and hence the SCR is turned OFF. The capacitor offers a very low or zero impedance to the high frequency pulse.

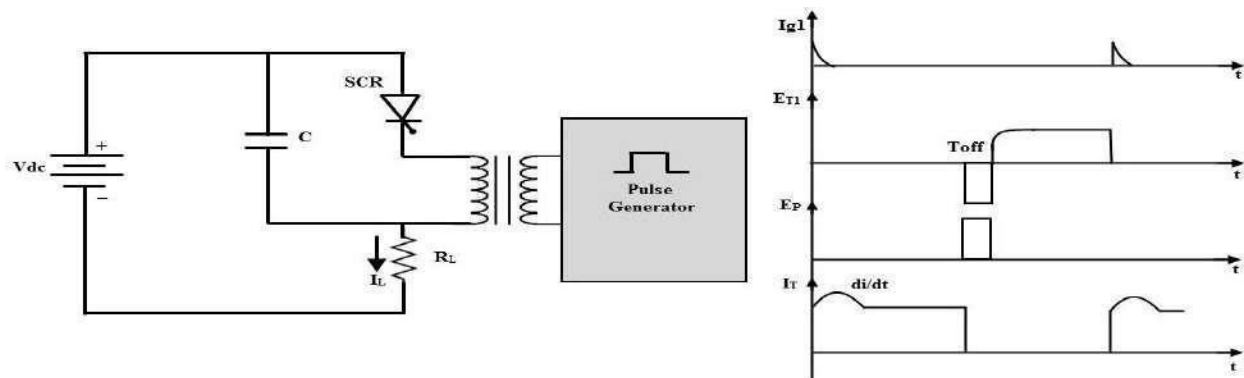

Figure: 1. 20. Class E Commutation circuit and waveforms

Natural Commutation

In natural commutation, the source of commutation voltage is the supply source itself. If the SCR is connected to an AC supply, at every end of the positive half cycle the anode current goes through the natural current zero and also immediately a reverse voltage is applied across the SCR. These are the conditions to turn OFF the SCR.

This method of commutation is also called as source commutation, or line commutation, or class F commutation. This commutation is possible with line commutated inverters, controlled rectifiers, cyclo converters and AC voltage regulators because the supply is the AC source in all these converters.

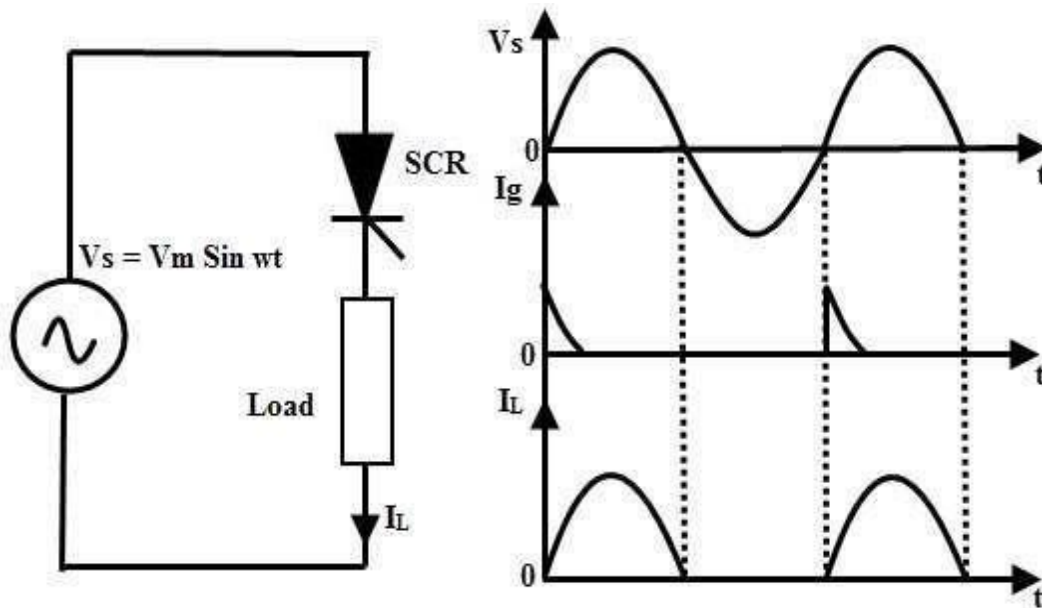

Figure: 1. 21. Natural Commutation circuit and waveforms

Dynamic Turn OFF Switching Characteristics

The transition of an SCR from forward conduction state to forward blocking state is called as turn OFF or commutation of SCR. As we know that once the SCR starts conducting, the gate has no control over it to bring back to forward blocking or OFF state.

To turn OFF the SCR, the current must be reduced to a level below the holding current of SCR. We have discussed various methods above to turn OFF the SCR in which SCR turn OFF is achieved by reducing

the forward current to zero. But if we apply the forward voltage immediately after the current zero of SCR, it starts conducting again even without gate triggering.

This is due to the presence of charge carriers in the four layers. Therefore, it is necessary to apply the reverse voltage, over a finite time across the SCR to remove the charge carriers.

Hence the turn OFF time is defined as the time between the instant the anode current becomes zero and the instant at which the SCR retains the forward blocking capability. The excess charge carriers from the four layers must be removed to bring back the SCR to forward conduction mode.

This process takes place in two stages. In a first stage excess carriers from outer layers are removed and in second stage excess carriers in the inner two layers are to be recombined. Hence, the total turn OFF time t_q is divided into two intervals; reverse recovery time t_{rr} and gate recovery time t_{gr} .

$$t_q = t_{rr} + t_{gr}$$

The figure below shows the switching characteristics of SCR during turn ON and OFF. The time t_1 to t_3 is called as reverse recovery time; at the instant t_1 the anode current is zero and builds up in the reverse direction which is called as reverse recovery current. This current removes the excess charge carriers from outer layers during the time t_1 to t_3 .

At instant t_3 , junctions J_1 and J_3 are able to block the reverse voltage but, the SCR is not yet able to block the forward voltage due to the presence of excess charge carriers in junction J_2 . These carriers can be disappeared only by the way of recombination and this could be achieved by maintaining a reverse voltage across the SCR.

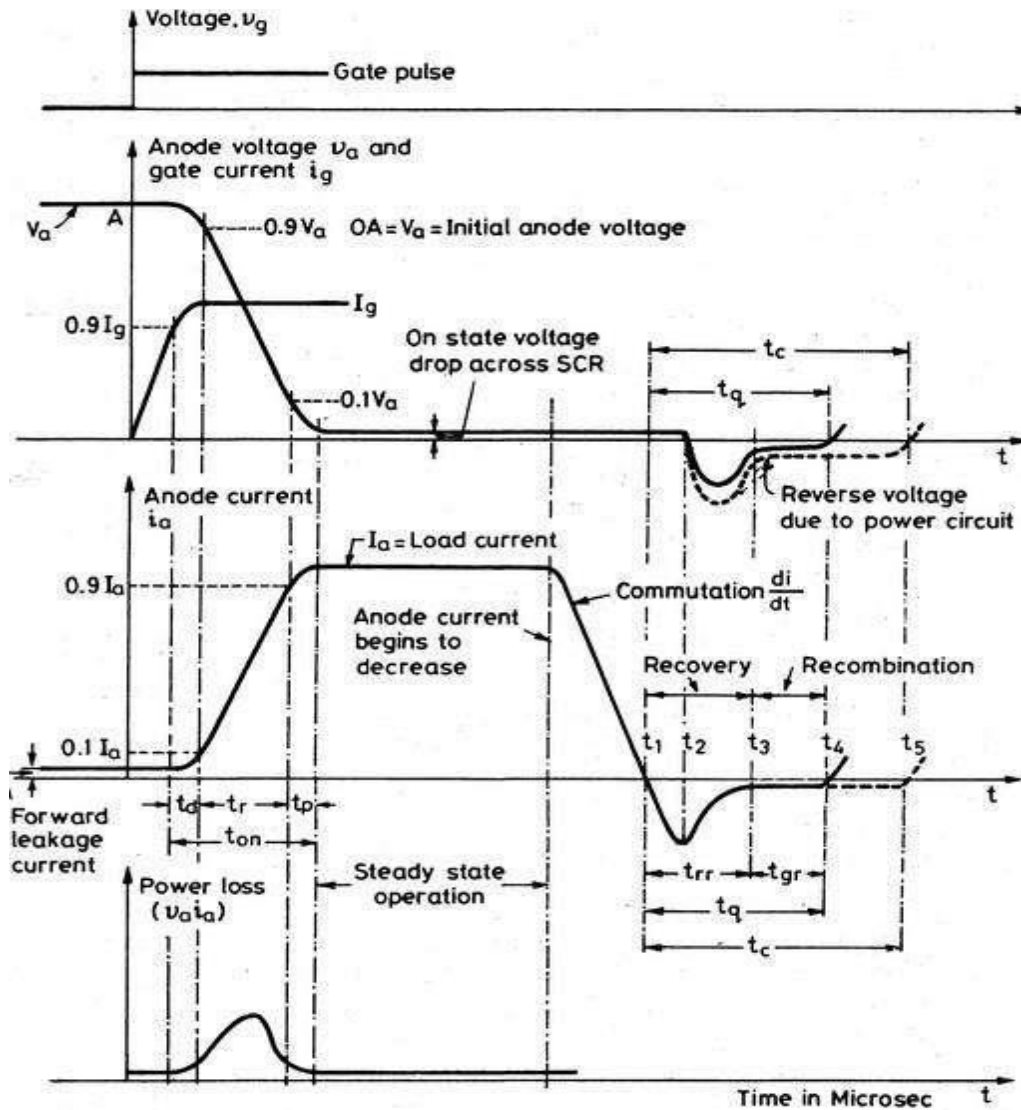

Figure: 1. 22. Dynamic characteristics of SCR

Hence , during the time t_3 to t_4 , the recombination of charges takes place and at the instant t_4 , junction J_2 completely recovers. This time is called gate recovery time t_{gr} .

- From the figure the turn OFF time is the time interval between the t_4 and t_1 . Generally, this time varies from 10 to 100 microseconds. This turn OFF time t_q is applicable to the individual SCR.
- The time required by the commutation circuit to apply the reverse voltage to commutate the SCR is called the circuit turn OFF time (t_c). For a safety margin or reliable commutation, this t_c must be greater than the t_q otherwise commutation failure occurs.

- The SCRs which have slow turn OFF time as in between 50 to 100 microseconds are called as converter grade SCRs. These are used in phase controlled rectifiers, cyclo converters, AC voltage regulators, etc.
- The SCRs which have fast turn OFF time as in between 3 to 50 microseconds are inverter grade SCRs. These are costlier compared to converter grade and are used in choppers, force commutated converters and inverters.

Resistance Firing Circuit

- The circuit below shows the resistance triggering of SCR where it is employed to drive the load from the input AC supply. Resistance and diode combination circuit acts as a gate control circuitry to switch the SCR in the desired condition.
- As the positive voltage applied, the SCR is forward biased and doesn't conduct until its gate current is more than minimum gate current of the SCR.
- When the gate current is applied by varying the resistance R2 such that the gate current should be more than the minimum value of gate current, the SCR is turned ON. And hence the load current starts flowing through the SCR.
- The SCR remains ON until the anode current is equal to the holding current of the SCR. And it will switch OFF when the voltage applied is zero. So the load current is zero as the SCR acts as open switch.
- The diode protects the gate drive circuit from reverse gate voltage during the negative half cycle of the input. And Resistance R1 limits the current flowing through the gate terminal and its value is such that the gate current should not exceed the maximum gate current.
- It is the simplest and economical type of triggering but limited for few applications due to its disadvantages.
- In this, the triggering angle is limited to 90 degrees only. Because the applied voltage is maximum at 90 degrees so the gate current has to reach minimum gate current value somewhere between zero to 90 degrees.

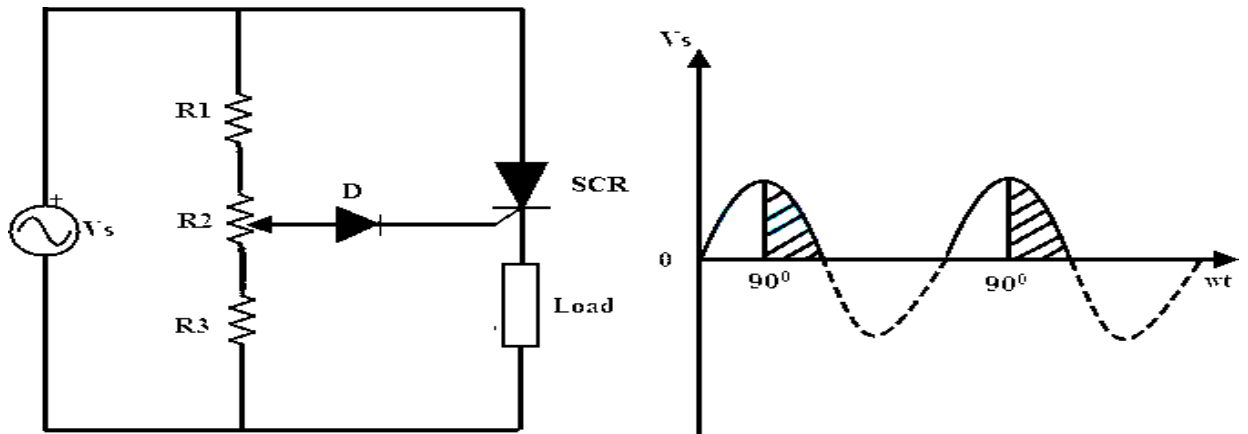

Figure: 1. 23. R Firing circuit for SCR and corresponding waveforms

Resistance – Capacitance (RC) Firing Circuit

- The limitation of resistance firing circuit can be overcome by the RC triggering circuit which provides the firing angle control from 0 to 180 degrees. By changing the phase and amplitude of the gate current, a large variation of firing angle is obtained using this circuit.
- Below figure shows the RC triggering circuit consisting of two diodes with an RC network connected to turn the SCR.
- By varying the variable resistance, triggering or firing angle is controlled in a full positive half cycle of the input signal.
- During the negative half cycle of the input signal, capacitor charges with lower plate positive through diode D2 up to the maximum supply voltage V_{max} . This voltage remains at $-V_{max}$ across the capacitor till supply voltage attains zero crossing.
- During the positive half cycle of the input, the SCR becomes forward biased and the capacitor starts charging through variable resistance to the triggering voltage value of the SCR.
- When the capacitor charging voltage is equal to the gate trigger voltage, SCR is turned ON and the capacitor holds a small voltage. Therefore the capacitor voltage is helpful for triggering the SCR even after 90 degrees of the input waveform.
- In this, diode D1 prevents the negative voltage between the gate and cathode during the negative half cycle of the input through diode D2.

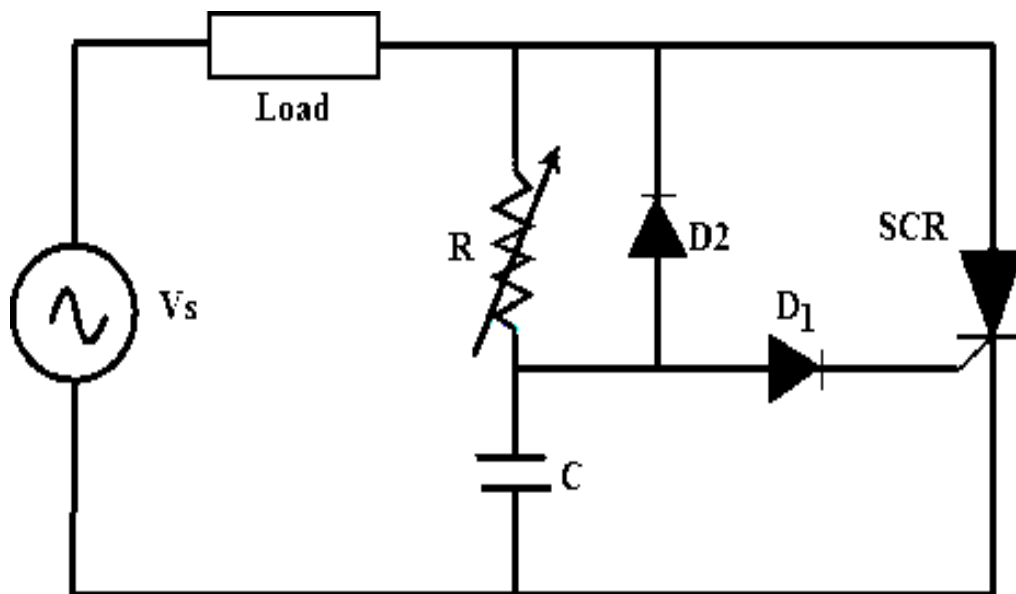

Figure: 1. 24. R Firing circuit for SCR

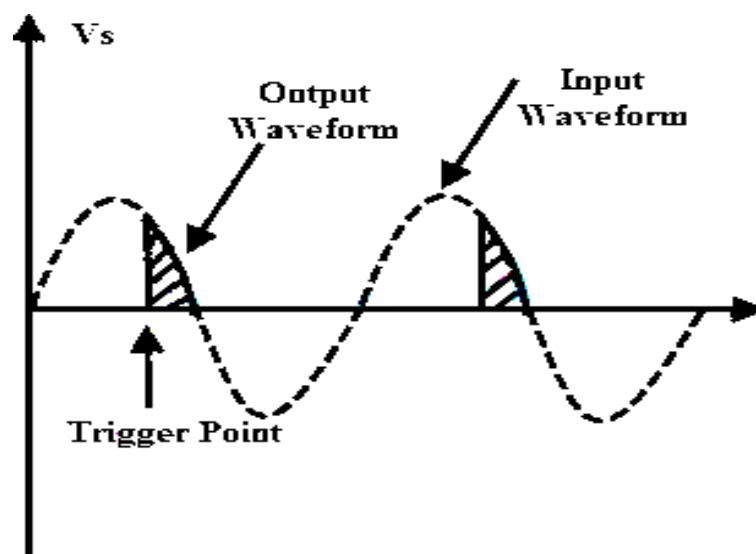

Figure: 1. 25. R Firing circuit waveforms of SCR

UJT Firing Circuit

- It is the most common method of triggering the SCR because the prolonged pulses at the gate using R and RC triggering methods cause more power dissipation at the gate so by using UJT (Uni Junction Transistor) as triggering device the power loss is limited as it produce a train of pulses.
- The RC network is connected to the emitter terminal of the UJT which forms the timing circuit. The capacitor is fixed while the resistance is variable and hence the charging rate of the capacitor depends on the variable resistance means that the controlling of the RC time constant.
- When the voltage is applied, the capacitor starts charging through the variable resistance. By varying the resistance value voltage across the capacitor get varied. Once the capacitor voltage is equal to the peak value of the UJT, it starts conducting and hence produce a pulse output till the voltage across the capacitor equal to the valley voltage V_v of the UJT. This process repeats and produces a train of pulses at base terminal 1.
- The pulse output at the base terminal 1 is used to turn ON the SCR at predetermined time intervals

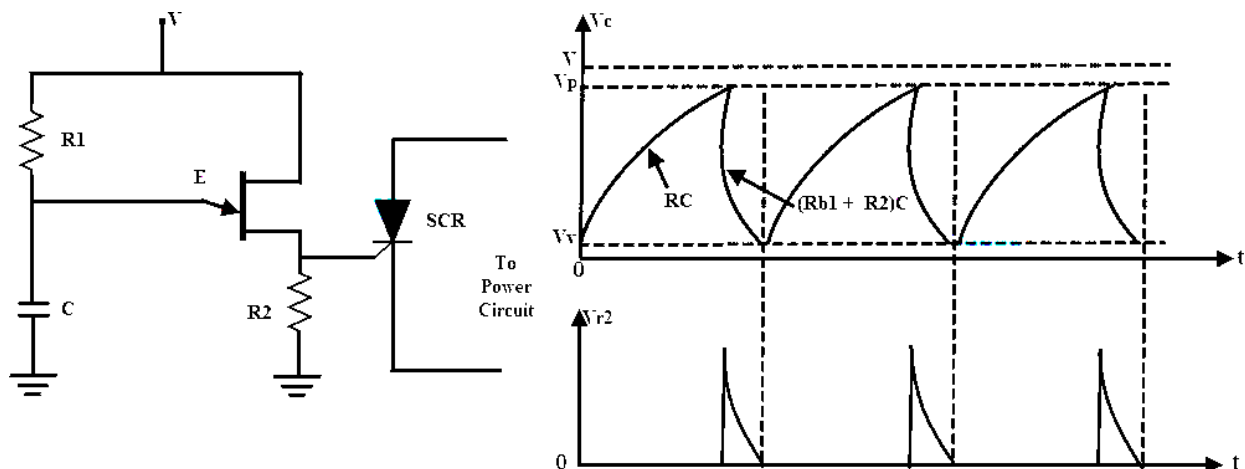

Figure: 1. 26. UJT Firing circuit for SCR and corresponding waveforms

Series and Parallel connections of SCRs

In many power control applications the required voltage and current ratings exceed the voltage and current that can be provided by a single SCR. Under such situations the SCRs are required to be connected in series or in parallel to meet the requirements. Sometimes even if the required rating is available, multiple connections are employed for reasons of economy and easy availability of SCRs of lower ratings. Like any other electrical equipment, characteristics/properties of two SCRs of same make and ratings are never same and this leads to certain problems in the circuit. The mismatching of SCRs is due to differences in

- (i) turn-on time
- (ii) turn-off time
- (iii) Leakage current in forward direction
- (iv) Leakage current in reverse direction and
- (v) Recovery voltage.

Series Connection of an SCR

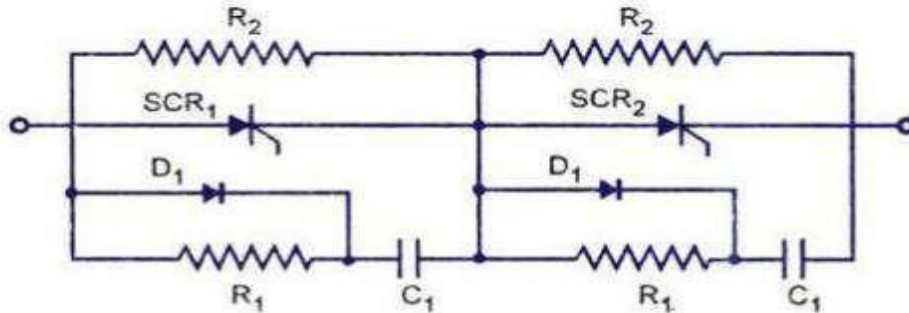

Figure: 1. 27. Series connection of SCRs

- (i) Unequal distribution of voltage across SCRs
- (ii) Difference in recovery characteristics.

Care must be taken to share the voltage equally. For steady-state conditions, voltage sharing is achieved by using a resistance or a Zener diode in parallel with each SCR. For transient voltage sharing a low non-inductive resistor and capacitor in series are placed across each SCR, as shown in figure. Diodes D₁ connected in parallel with resistor R₁, helps in dynamic stabilization. This circuit reduces differences between blocking voltages of the two devices within permissible limits. Additionally the R-C circuit can also serve the function of 'snubber circuit'. Values of R₁ and C₁ can primarily be calculated for snubber circuit and a check can be made for equalization. If ΔQ is the difference in recovery charge of two devices arising out of different recovery current for different time and ΔV is the permissible difference in blocking voltage then

$$C_1 = \Delta Q / \Delta V$$

The value of resistance R_x should be sufficient to over damp the circuit. Since the capacitor C₁ can discharge through the SCR during turn-on, there can be excessive power dissipation, but the switching current from C₁ is limited by the resistor R₁. This resistance also serves the purpose of

damping out 'ringing' which is oscillation of C1 with the circuit inductance during commutation. All the SCRs connected in series should be turned-on at the same time when signals are applied to their gates simultaneously.

$$\text{String efficiency} = \frac{\text{Voi or actual current rating of the whole string}}{\text{No of SCRs in string} \times \text{Voi or current rating of individual SCR}}$$

This phenomenon increases the reliability of the string, but reduces the utilization of each SCR. Thus string efficiency decreases. Reliability of string is measured by derating factor (DRF) which is given by the expression

$$\text{DRF} = 1 - \text{string efficiency}$$

Parallel Connection of an SCR

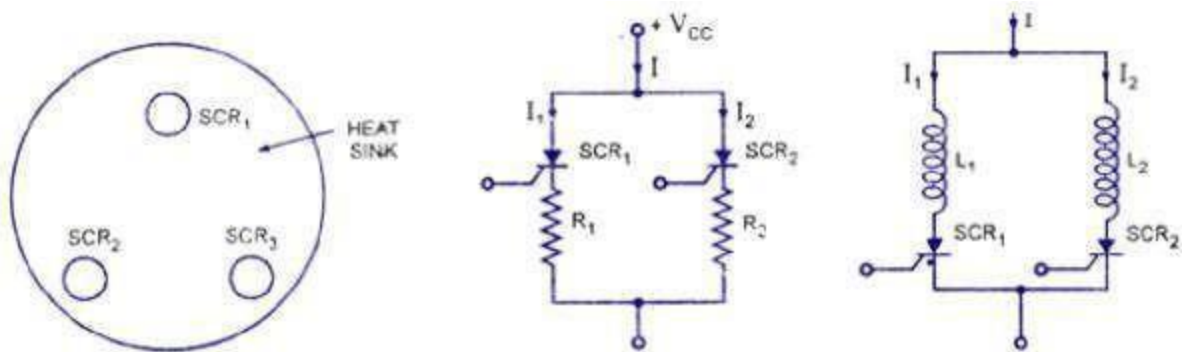

Figure: 1.28. Parallel connection of SCRs

When the load current exceeds the SCR current rating, SCRs are connected in parallel to share the load current. But when SCRs are operated in parallel, the current sharing between them may not be proper. The device having lower dynamic resistance will tend to share more current. This will raise the temperature of that particular device in comparison to other, thereby reducing further its dynamic resistance and increasing current through it. This process is cumulative and continues till the device gets punctured. Some other factors which directly or indirectly add to this problem are difference in turn-on time, delay time, finger voltage and loop inductance.

Arrangement of SCRs in the cubicle also plays vital role. When the SCRs are connected in parallel, it must be ensured that the latching current level of the all the SCRs is such that when gate pulse is applied, all of them turn-on and remain on when the gate pulse is removed. Further the holding

currents of the devices should not be so much different that at reduced load current one of the device gets turned-off because of fall of current through it below its holding current value. This is particularly important because on increase in load current, the device which has stopped conducting cannot start in the absence of gate pulse.

Another point to be considered is the on-state voltage across the device. For equal sharing of currents by the devices voltage drop across the parallel paths must be equal. For operation of all the SCRs connected in parallel at the same temperature, it becomes necessary to use a common heat sink for their mounting, as illustrated in figure. Resistance compensation used for dc circuits is shown in figure. In this circuit the resistors R_1 and R_2 are chosen so as to cause equal voltage drop in both arms. Inductive compensation used for ac circuits is shown in figure. The difference in characteristics due to different turn-on time, delay time, forward voltage, latching current, holding current can be minimized by using inductive compensation. Firing circuits giving high rate of rise can be used to reduce mismatch of gate characteristics and delay time. Current sharing circuits must be designed so as to distribute current equally at maximum temperature and maximum anode current. This is done to ensure that the devices share current equally under worst operating conditions. Mechanical arrangement of SCRs also plays an important role in reducing mismatching. Cylindrical construction is perhaps the best from this point of view.

Derating:

Even with all the measures taken, it is preferable to derate the device for series/parallel operation. Another reason for derating is poor cooling and heat dissipation as number of devices operates in the same branch of the circuit. Normal derating factors are 10 to 15% for parallel connection of SCRs depending upon the number of devices connected in parallel. Higher voltage safety factor is taken when SCRs are connected in series.

Numerical Problems:

1. The trigger circuit of a thyristor has a source voltage of 15V and the load line has a slope of -120V per ampere. The minimum gate current to turn on the SCR is 25mA. Compute
 - i. Source resistance required in the gate circuit
 - ii. The trigger voltage and trigger current for an average gate power dissipation of 0.4 watts

Solution:

- i. The slope of load line gives the required gate source resistance. From the load line, series resistance required in the gate circuit is 120Ω
- ii. Here $V_g I_g = 0.4W$

For the gate circuit $E_s = R_s I_g + V_g$

$$15 = 120I_g + 0.4/I_g$$

$$120I_g^2 - 15 I_g + 0.4 = 0$$

Its solution gives $I_g = 38.56mA$ or $86.44 mA$

$$V_g = \frac{0.4 \times 1000}{38.56} = 10.37V$$

$$V_g = \frac{0.4 \times 1000}{.44} = 4.627V$$

So choose the value for I_g which gives less voltage $I_g = 86.44 mA$ and $V_g = 4.627V$ from minimum gate current of 25mA.

2. For an SCR the gate-cathode characteristic has a straight line slope of 130. For trigger source voltage of 15V and allowable gate power dissipation of 0.5 watts, compute the gate source resistance.
3. SCRs with a rating of 1000V and 200A are available to be used in a string to handle 6kV and 1kA. Calculate the number of series and parallel units required in case de-rating factor is 0.1 and 0.2

4. It is required to operate 250A SCR in parallel with 350A SCR with their respective on state voltage drops of 1.6V and 1.2V. Calculate the value of resistance to be inserted in series with each SCR so that they share the total load of 600A in proportion to their current ratings.

Snubber circuit

Due to overheating, over voltage, over current or excessive change in voltage or current switching devices and circuit components may fail. From over current they can be protected by placing fuses at suitable locations. Heat sinks and fans can be used to take the excess heat away from switching devices and other components. Snubber circuits are needed to limit the rate of change in voltage or current (**di/dt** or **dv/dt**) and over voltage during turn-on and turn-off. These are placed across the semiconductor devices for protection as well as to improve the performance. Static **dv/dt** is a measure of the ability of a thyristor to retain a blocking state under the influence of a voltage transient. These are also used across the relays and switches to prevent arcing.

Necessity of Using the Snubber Circuit

These are placed across the various switching devices like transistors, thyristors, etc. Switching from ON to OFF state results the impedance of the device suddenly changes to the high value. But this allows a small current to flow through the switch. This induces a large voltage across the device. If this current reduced at faster rate more is the induced voltage across the device and also if the switch is not capable of withstanding this voltage the switch becomes burn out. So auxiliary path is needed to prevent this high induced voltage

Similarly when the transition is from OFF to ON state, due to uneven distribution of the current through the area of the switch overheating will take place and eventually it will be burned. Here also snubber is necessary to reduce the current at starting by making an alternate path.

Snubbers in switching mode provides one or more of the following functions

- Shape the load line of a bipolar switching transistor to keep it in its safe operating area.
- Reducing the voltages and currents during turn-ON and turn-OFF transient conditions.
- Removes energy from a switching transistor and dissipate the energy in a resistor to reduce junction temperature.
- Limiting the rate of change of voltage and currents during the transients.
- Reduce ringing to limit the peak voltage on a switching transistor and lowering their frequency.

Design of RC Snubber Circuits:

There are many kinds of snubbers like RC, diode and solid state snubbers but the most commonly used one is RC snubber circuit. This is applicable for both the rate of rise control and damping.

This circuit is a capacitor and series resistor connected across a switch. For designing the Snubber circuits. The amount of energy is to dissipate in the snubber resistance is equal to the amount of energy is stored in the capacitors. An RC Snubber placed across the switch can be used to reduce the peak voltage at turn-off and to damp the ring. An RC snubber circuit can be polarized or non-polarized. If you assume the source has negligible impedance, the worst case peak current in the snubber circuit is

$$I = V_o/R_s \text{ and } I = C \cdot dv/dt$$

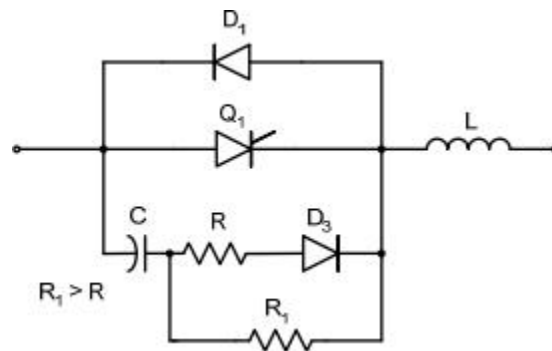

Figure: 1. 29. Forward-Polarized RC Snubber Circuit

For an appropriate forward-polarized RC snubber circuit a thyristor or a transistor is connected with an anti-parallel diode. R will limit the forward dv/dt and R_1 limits the discharge current of the capacitor when thyristor Q_1 is turned on. These are used as overvoltage snubbers to clamp the voltage.

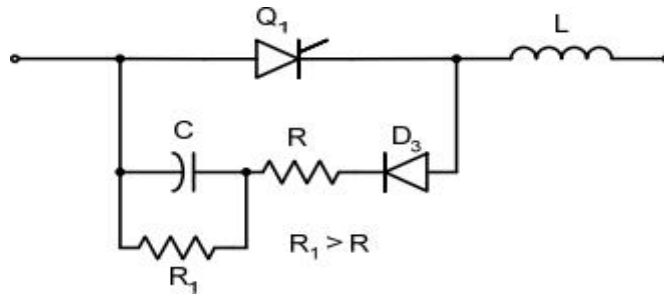

Figure: 1. 30. Reverse Polarized RC Snubber Circuit

Reverse polarized snubber circuit can be used to limit the reverse dv/dt . R1 will limit the discharge current of the capacitor.

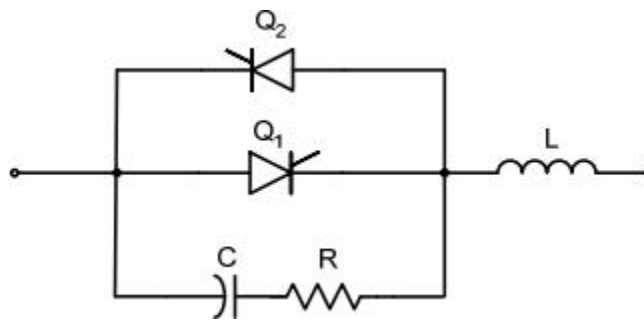

Figure: 1. 31. An un-polarized snubber circuit

An un-polarized snubber circuit is used when a pair of switching devices is used in anti-parallel. For determining the resistor and capacitor values a simple design technique can be used. For this an optimum design is needed. Hence a complex procedure will be used. These can be used to protect and thyristors.

Capacitors selection:

Snubber capacitors are subjected to high peak and RMS currents and high dv/dt . An example is turn-on and turn-off current spikes in a typical RCD snubber capacitor. The pulse will have high peak and RMS amplitudes. The snubber capacitor has to meet two requirements. First, the energy stored in the snubber capacitor must be greater than the energy in the circuit's inductance. Secondly, the time constant of snubber circuits should be small compared to shortest on time expected, usually 10% of the on time. By allowing the resistor to be effective in the ringing frequency this capacitor is used to minimize the

dissipation at switching frequency. The best design is selecting the impedance of the capacitor is same that of resistor at the ringing frequency.

Resistors selection:

It is important that R in the RC snubber, have low self inductance. Inductance in R will increase the peak voltage and it will tend to defeat the purpose of the snubber. Low inductance will also be desirable for R in snubber but it is not critical since the effect of a small amount of inductance is to slightly increase the reset time of C and it will reduce the peak current in switch at turn-on. The normal choice of R is usually the carbon composition or metal film. The resistor power dissipation must be independent of the resistance R because it dissipates the energy stored in the snubber capacitor in each transition of voltage in the capacitor. If we select the resistor as that the characteristic impedance, the ringing is well damped.

When comparing the Quick design to optimum design, the required snubber resistor’s power capability will be reduced. Usually the “Quick” design is completely adequate for final design. Going to the “Optimum” approach is only if power efficiency and size constraints dictate the need for optimum design.

Power Bipolar Junction Transistor (BJT)

Power BJT is used traditionally for many applications. However, IGBT (Insulated-Gate Bipolar Transistor) and MOSFET (Metal-Oxide-Semiconductor Field-Effect Transistor) have replaced it for most of the applications but still they are used in some areas due to its lower saturation voltage over the operating temperature range. IGBT and MOSFET have higher input capacitance as compared to BJT. Thus, in case of IGBT and MOSFET, drive circuit must be capable to charge and discharge the internal capacitances.

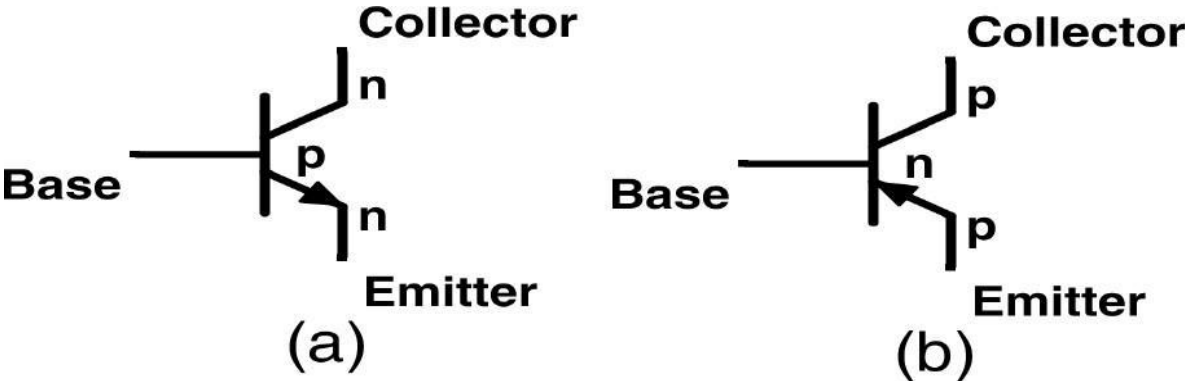

Figure: 1. 32. Symbol of transistor

The BJT is a three-layer and two-junction npn or pnp semiconductor device as given in Fig. 32. (a) and (b).

Although BJTs have lower input capacitance as compared to MOSFET or IGBT, BJTs are considerably slower in response due to low input impedance. BJTs use more silicon for the same drive performance.

In the case of MOSFET studied earlier, power BJT is different in configuration as compared to simple planar BJT. In planar BJT, collector and emitter is on the same side of the wafer while in power BJT it is on the opposite edges as shown in Fig. 33. This is done to increase the power-handling capability of BJT.

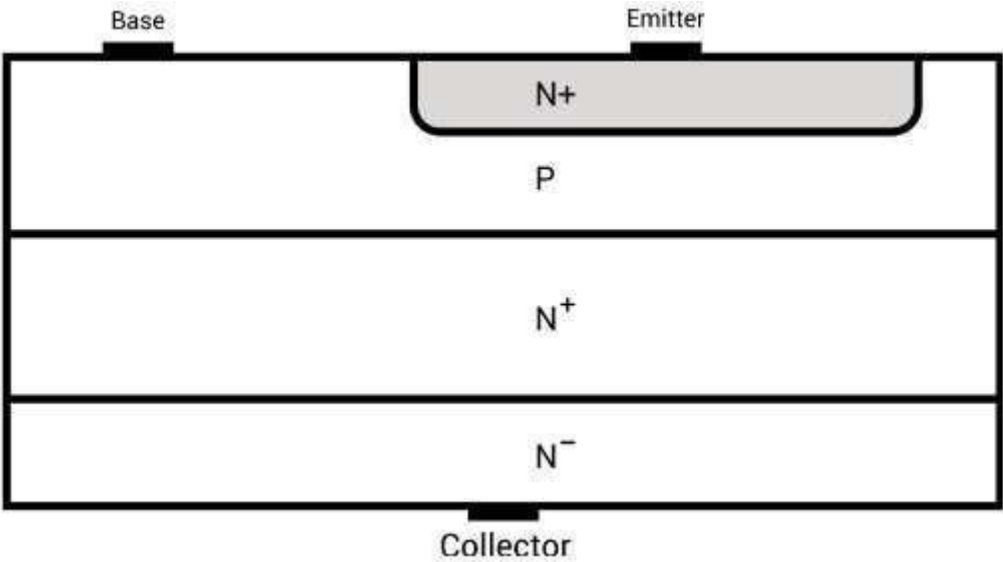

Figure: 1. 33. Structure of transistor

Power n-p-n transistors are widely used in high-voltage and high-current applications which will be discussed later.

Input and output characteristics of planar BJT for common-emitter configuration are shown in Fig. 34. These are current-voltage characteristics curves.

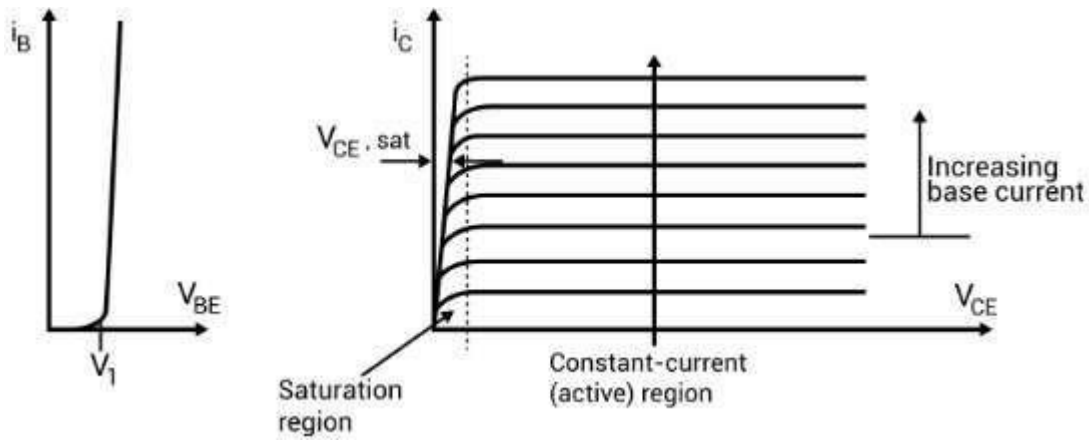

Figure: 1.34. Input and output characteristics of BJT

Metal-Oxide Semiconductor Field-Effect Transistor (Power)

MOSFET is a voltage-controlled majority carrier (or unipolar) three-terminal device. As compared to the simple lateral channel MOSFET for low-power signals, power MOSFET has different structure. It has a vertical channel structure where the source and the drain are on the opposite side of the silicon wafer as shown in Figure. This opposite placement of the source and the drain increases the capability of the power MOSFET to handle larger power.

N-channel enhancement type MOSFET is more common due to high mobility of electrons.

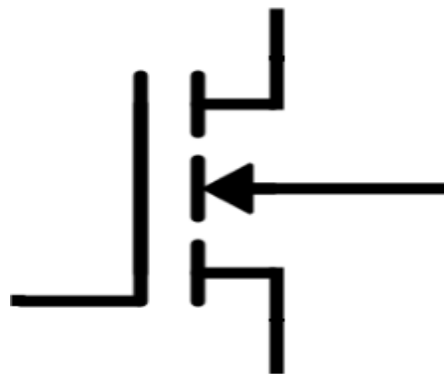

Figure: 1.35. Symbol of MOSFET

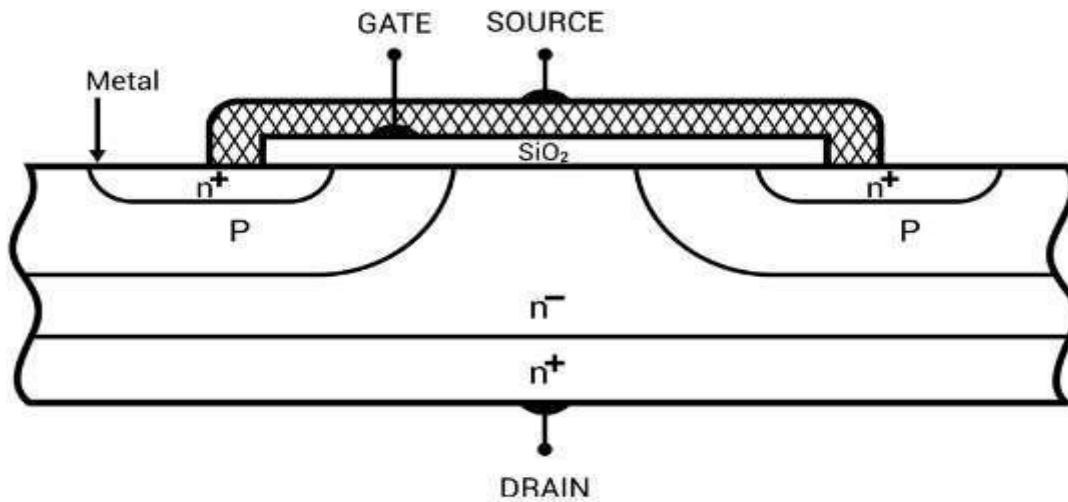

Figure: 1. 36. Structure of MOSFET

Basic circuit diagram and output characteristics of an n-channel enhancement power MOSFET with load connected are in Fig. 37 and Fig. 38 respectively.

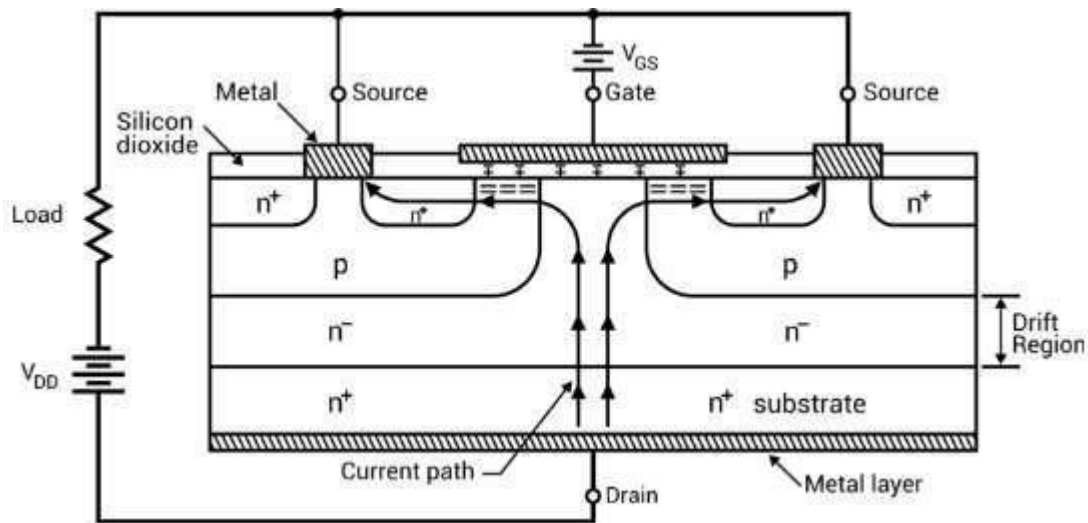

Figure: 1. 37. Basic circuit diagram of n-channel enhancement power MOSFET

Drift region shown in Fig. 37 determines the voltage-blocking capability of the MOSFET.

When $V_{GS} = 0$,

$\Rightarrow V_{DD}$ makes it reverse biased and no current flows from drain to source.

When $V_{GS} > 0$,

⇒ Electrons form the current path as shown in Fig. 37. Thus, current from the drain to the source flows. Now, if we will increase the gate-to-source voltage, drain current will also increase.

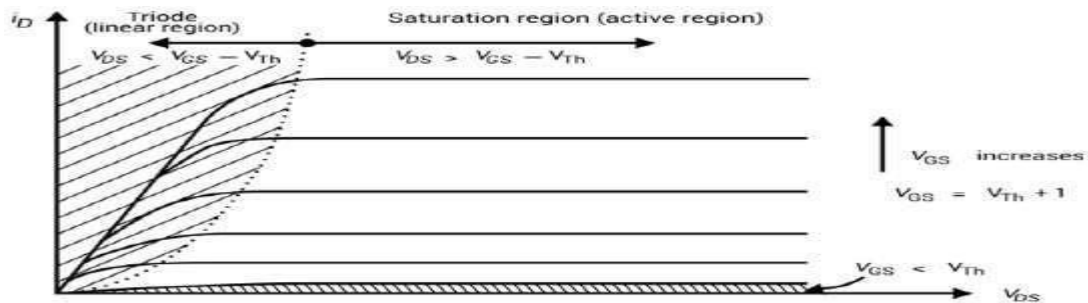

Figure: 1.38. Output characteristics of an n-channel enhancement power MOSFET

For lower value of V_{DS} , MOSFET works in a linear region where it has a constant resistance equal to V_{DS} / I_D . For a fixed value of V_{GS} and greater than threshold voltage V_{TH} , MOSFET enters a saturation region where the value of the drain current has a fixed value.

Besides the output characteristics curves, transfer characteristics of power MOSFET is also shown in Fig. 39.

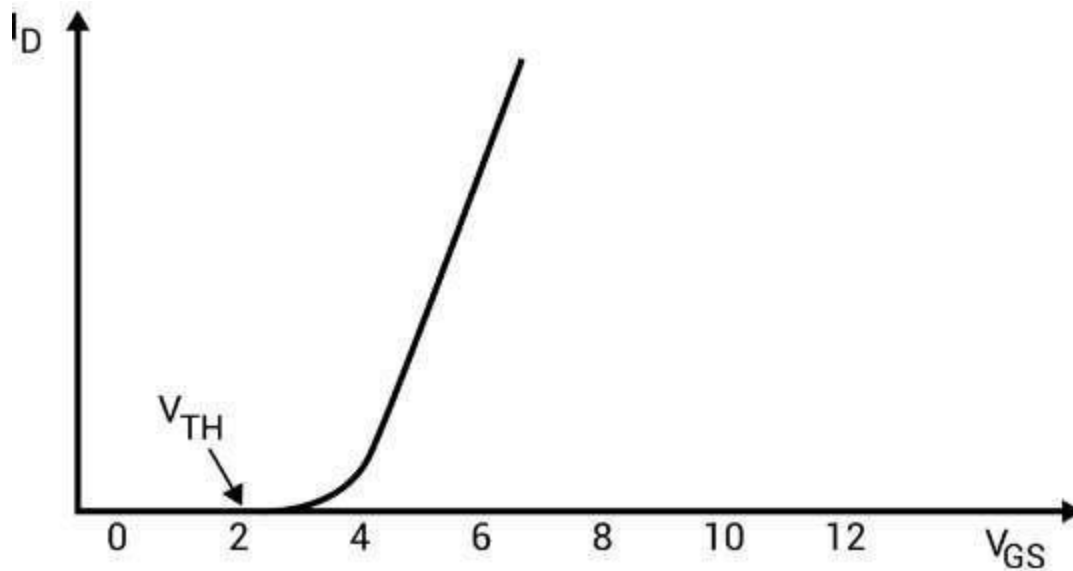

Figure: 1.39. Transfer characteristics of an n-channel enhancement power MOSFET

Insulated-Gate Bipolar Transistor (IGBT)

IGBT combines the physics of both BJT and power MOSFET to gain the advantages of both worlds. It is controlled by the gate voltage. It has the high input impedance like a power MOSFET and has low on-state power loss as in case of BJT. There is no even secondary breakdown and not have long switching time as in case of BJT. It has better conduction characteristics as compared to MOSFET due to bipolar nature. It has no body diode as in case of MOSFET but this can be seen as an advantage to use external fast recovery diode for specific applications. They are replacing the MOSFET for most of the high voltage applications with less conduction losses. Its physical cross-sectional structural diagram and equivalent circuit diagram is presented in Fig. 40 to Fig. 41. It has three terminals called collector, emitter and gate.

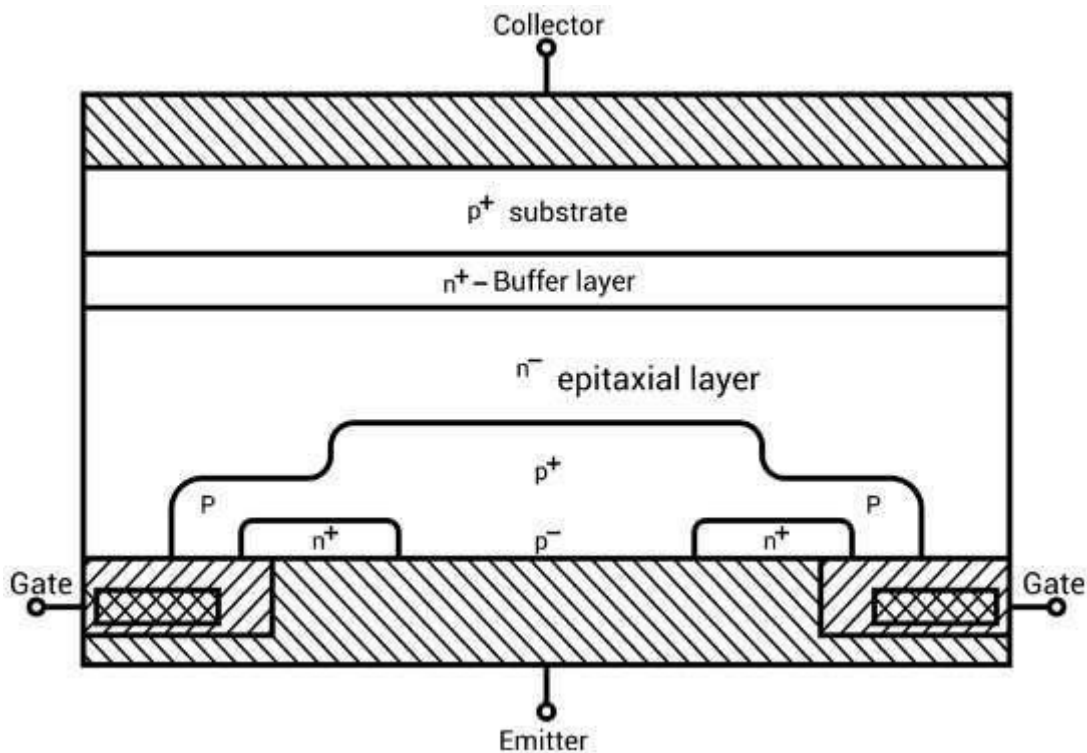

Figure: 1. 40. Cross -sectional structural diagram of IGBT

There is a p^+ substrate which is not present in the MOSFET and responsible for the minority carrier injection into the n -region. Gain of NPN terminal is reduced due to wide epitaxial base and n^+ buffer layer.

There are two structures of IGBTs based on doping of buffer layer:

a) Punch-through IGBT: Heavily doped n buffer layer \rightarrow less switching time

b) Non-Punch-through IGBT: Lightly doped n buffer layer \rightarrow greater carrier lifetime \rightarrow increased conductivity of drift region \rightarrow reduced on-state voltage drop

(Note: \rightarrow means implies)

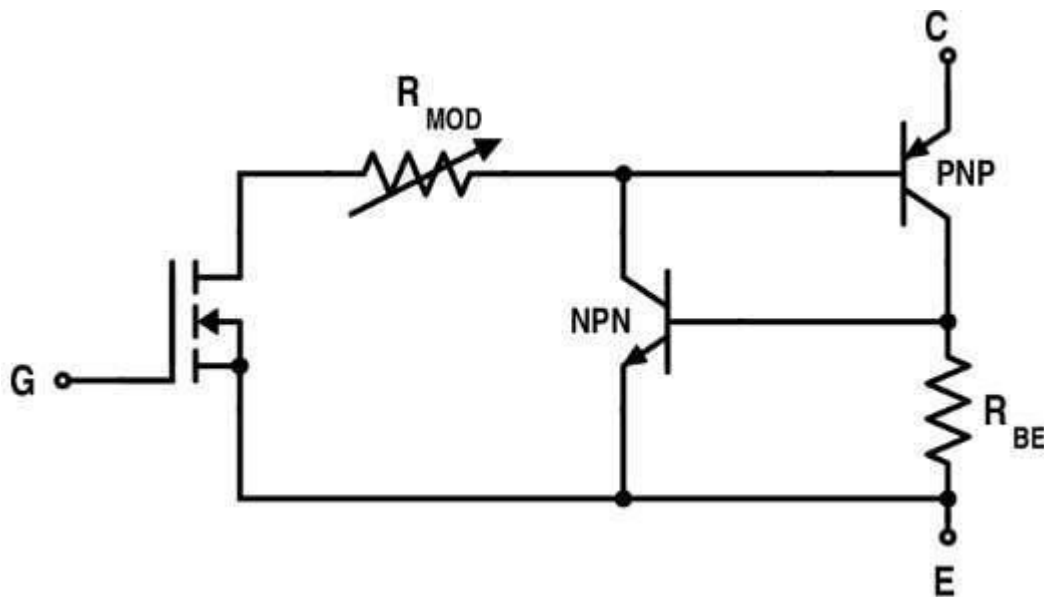

Figure: 1. 41. Equivalent diagram of IGBT

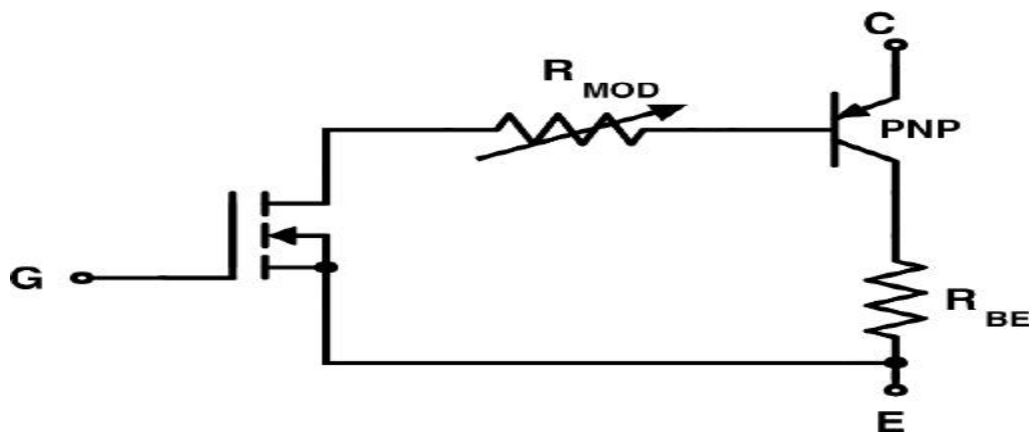

Figure: 1. 42. Simplified Equivalent diagram of IGBT

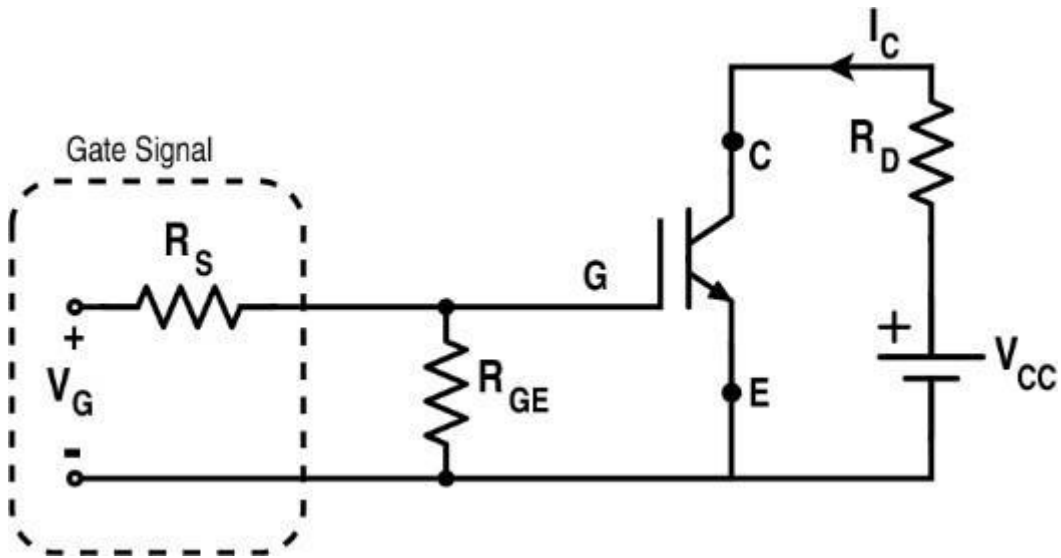

Figure: 43. Equivalent diagram of IGBT

Based on this circuit diagram given in Fig. 43, forward characteristics and transfer characteristics are obtained which are given in Fig. 44 and Fig. 45. Its switching characteristic is also shown in Fig. 45.

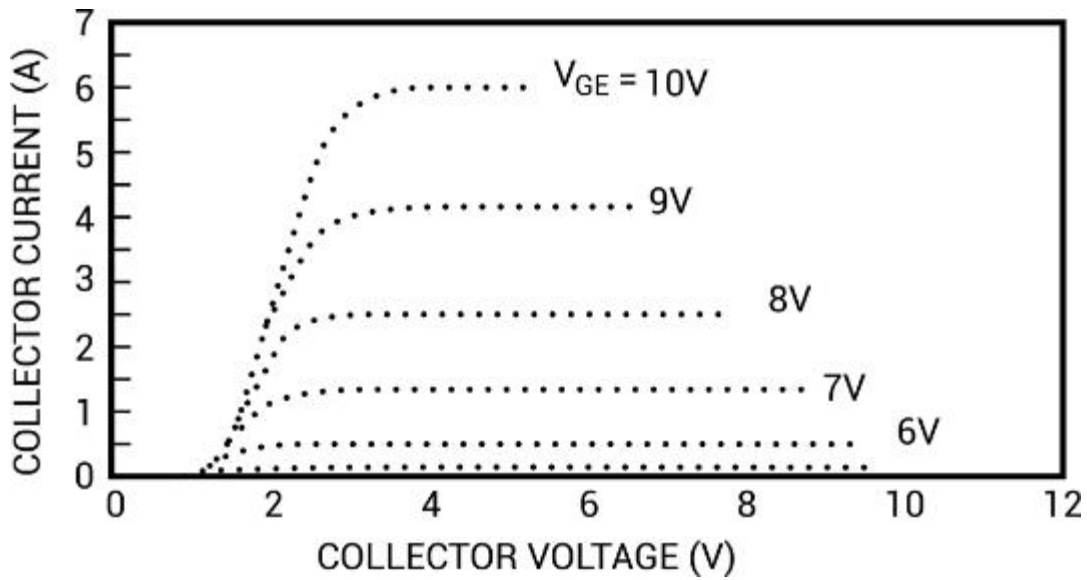

Figure: 1. 44. Forward characteristics of IGBT

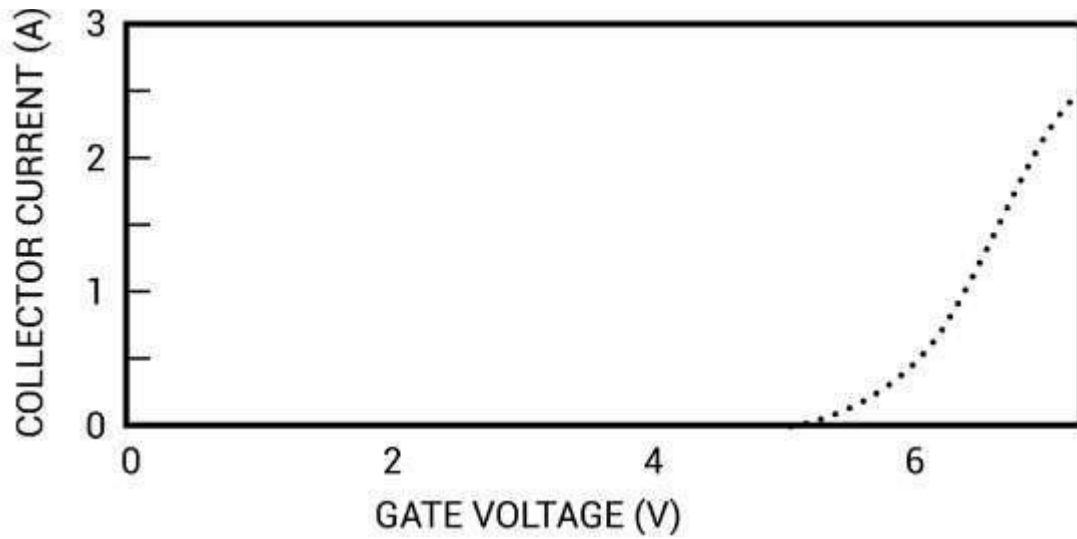

Figure: 1.45. Transfer characteristics of IGBT

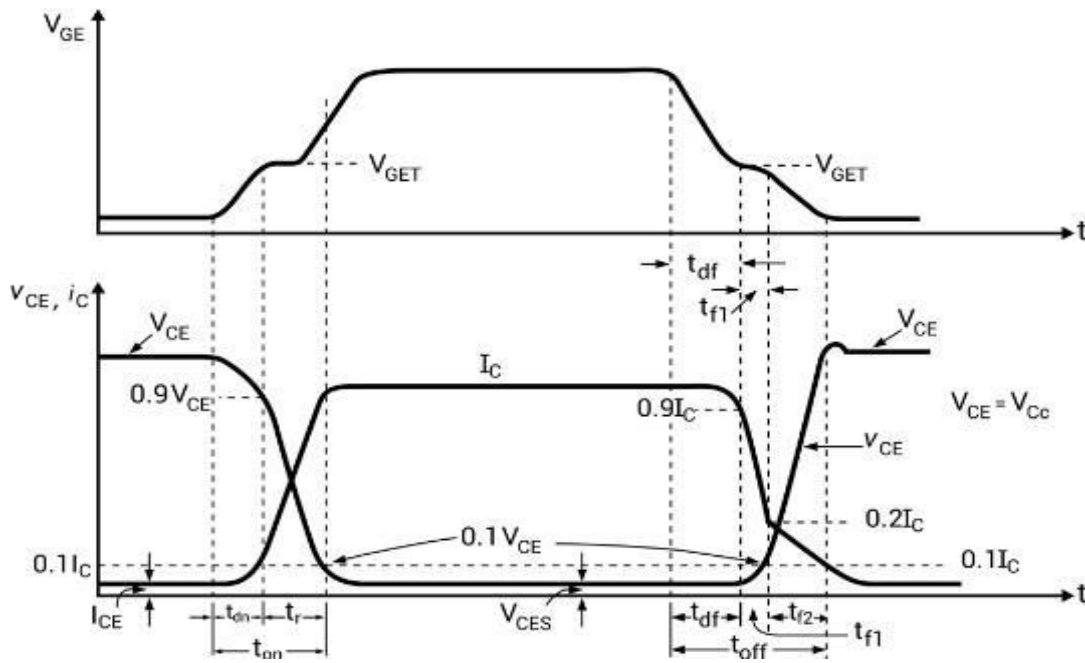

Figure: 1.46. Dynamic characteristics of IGBT

(Note: T_{dn} : delay time ; T_r : rise time ; T_{df} : delay time ; T_{f1} : initial fall time ; T_{f2} : final fall time)

GTO (Gate Turn-off Thyristor)

GTO can be turned on with the positive gate current pulse and turned off with the negative gate current pulse. Its capability to turn off is due to the diversion of PNP collector current by the gate and thus breaking the regenerative feedback effect.

Actually the design of GTO is made in such a way that the pnp current gain of GTO is reduced. A highly doped n spot in the anode p layer form a shorted emitter effect and ultimately decreases the current gain of GTO for lower current regeneration and also the reverse voltage blocking capability. This reduction in reverse blocking capability can be improved by diffusing gold but this reduces the carrier lifetime. Moreover, it requires a special protection.

The symbol for GTO is shown in Fig.46.

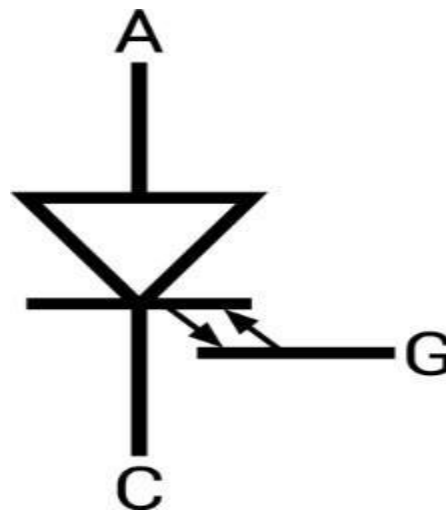

Figure: 1. 47. Symbol of GTO

Overall switching speed of GTO is faster than thyristor (SCR) but voltage drop of GTO is larger. The power range of GTO is better than BJT, IGBT or SCR.

The static voltage current characteristics of GTO are similar to SCR except that the latching current of GTO is larger (about 2 A) as compared to SCR (around 100-500 mA).

The gate drive circuitry with switching characteristics is given in Fig. 48 and Fig. 49.

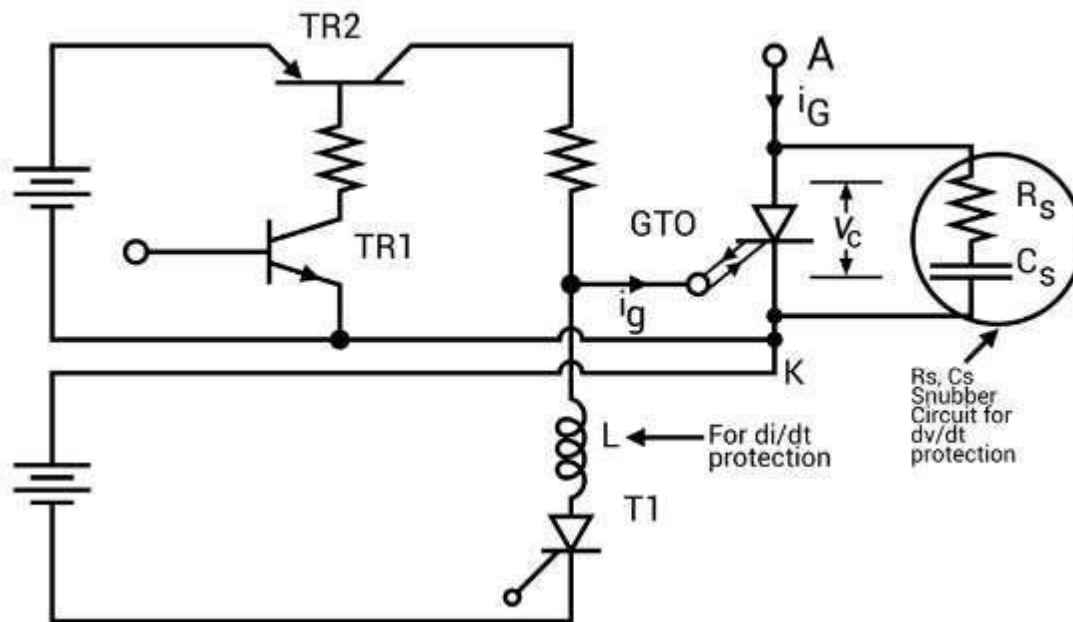

Figure: 1. 48. Gate Drive Circuit for GTO

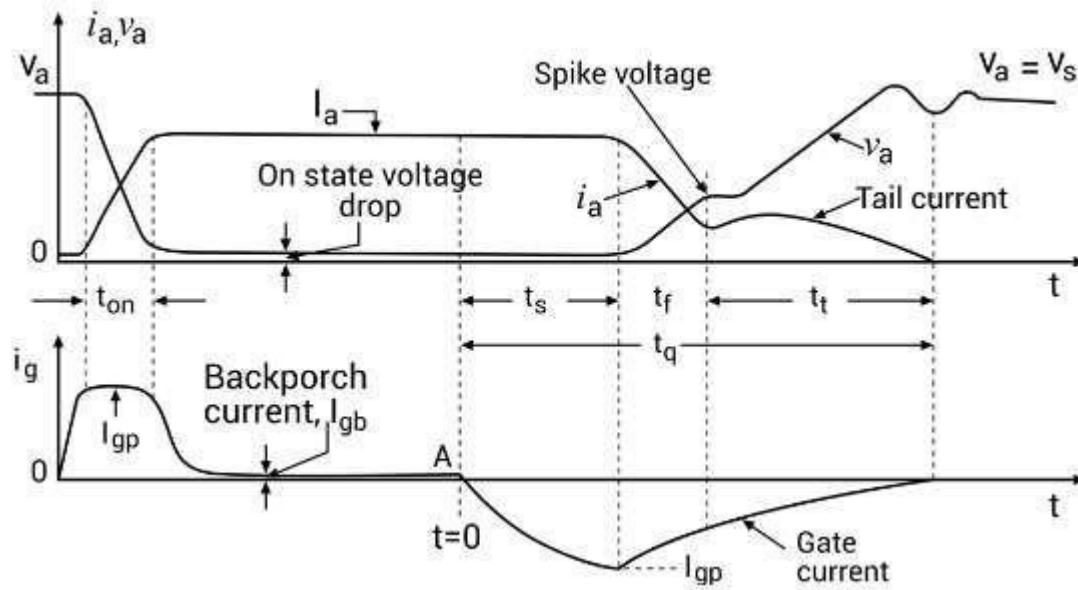

Figure: 1. 49. Switching characteristics for GTO

SCR Specifications and Ratings:

The main specifications of the SCR are its voltage rating and current rating. In this post, let us see various ratings of thyristor.

Voltage Ratings

Peak Inverse Voltage (V_{PIV})

The peak inverse voltage is defined as the maximum voltage which SCR can safely withstand in its OFF state. The applied voltage should never be exceeded under any circumstances.

On State Voltage:

The voltage which appears across the SCR during its ON state is known as its ON state Voltage. The maximum value of voltage which can appear across the SCR during its conducting state is called its maximum on state voltage. Usually it will be 1V to 4V.

Finger Voltage:

The minimum voltage, which is required between the anode and cathode of an SCR to trigger it to conduction mode, is called its finger voltage.

Rate of Rise of Voltage (dV/dt)

The rate at which the voltage across the device rises (for forward condition) without triggering the device, is known as its rate of rise of voltage.

Voltage Safety Factor:

The normal operating voltage of the SCR is kept well below its peak inverse voltage(V_{PIV}) to avoid puncture of SCR due to uncertain conditions. The operating voltage and peak inverse voltage are related by voltage safety factor V_f

$$V_f = \text{Peak inverse voltage} / (2 \times \text{RMS value of input voltage})$$

Normally V_f value lies between 2 and 2.5

Current Ratings:

The current carrying capacity of the device is known as its current rating.

It can be of two types.

1. Continuous
2. Intermittent.

Maximum average ON state current (I_{mac}):

This is the average value of maximum continuous sinusoidal ON state current with conduction angle 180deg, at frequency 40 to 60Hz, which should not be exceeded even with intensive cooling.

Maximum rms ON-state current: (I_{mrc})

It is the rms value of the maximum continuous sinusoidal ON state current at the frequency 40 to 60 Hz and conduction angle 180deg, which should not be exceeded even with intensive cooling.

Maximum surge - ON state Current (I_{msc})

It is the maximum admissible peak value of a sinusoidal half cycle of ten milliseconds duration at a frequency of 50Hz.

Latching Current (I_l)

It is the minimum current, which is required to latch the device from its OFF state to its ON state. In other words, it is the minimum current required to trigger the device.

Holding Current (I_H)

It is the minimum current required to hold the SCR conducting. In other words, It is the minimum current, below which the device stops conducting and returns to its OFF state.

Gate Current:

The current which is applied to the gate of the device for control purposes is known as gate current.

Minimum Gate Current:

The minimum current required at the gate for triggering the device.

Maximum Gate Current:

The maximum current which can be applied to device safely. Current higher than this will damage the gate terminal.

Gate Power Loss:

The mean power loss, which occurs due to flow of gate current between the gate and the main terminals.

Turn ON time:

The time taken by the device before getting latched from its OFF state to ON state. In other words, it is the time for which the device waits before achieving its full conduction. Usually it will be 150 to 200μsec.

Turn OFF time:

After applying reverse voltage, the device takes a finite time to get switched OFF. This time is called as turn-OFF time of the device. Usually it will be 200μsec.

Rate of rise of current (dI/dt)

The rate at which the current flowing in the device rises is known as its rate of rise (dI/dt) of current.

Comparison between BJT and MOSFET:

Sl No	BJT	MOSFET
1	It is a Bipolar Device	It is majority carrier Device
2	Current control Device	Voltage control Device.
3	Output is controlled by controlling base current	Output is controlled by controlling gate voltage
4	Negative temperature coefficient	Positive temperature coefficient
5	So paralleling of BJT is difficult.	So paralleling of this device is easy.
6	Dive circuit is complex. It should provide constant current(Base current)	Dive circuit is simple. It should provide constant voltage(gate voltage)
7	Losses are low.	Losses are higher than BJTs.
8	So used in high power applications.	Used in low power applications.
9	BJTs have high voltage and current ratings.	They have less voltage and current ratings.
10	Switching frequency is lower than MOSFET.	Switching frequency is high.

UNIT – II

Single phase and three phase controlled rectifiers

Phase control technique – Single phase Line commutated converters

Unlike diode rectifiers, PCR or phase controlled rectifiers has an advantage of regulating the output voltage. The diode rectifiers are termed as uncontrolled rectifiers. When these diodes are switched with Thyristors, then it becomes phase control rectifier. The o/p voltage can be regulated by changing the firing angle of the Thyristors. The main application of these rectifiers is involved in speed control of DC motor.

What is a Phase Controlled Rectifier?

The term PCR or Phase controlled rectifier is a one type of rectifier circuit in which the diodes are switched by Thyristors or SCRs (Silicon Controlled Rectifiers). Whereas the diodes offer no control over the o/p voltage, the Thyristors can be used to differ the output voltage by adjusting the firing angle or delay. A phase control Thyristor is activated by applying a short pulse to its gate terminal and it is deactivated due to line communication or natural. In case of heavy inductive load, it is deactivated by firing another Thyristor of the rectifier during the negative half cycle of i/p voltage.

Types of Phase Controlled Rectifier

The phase controlled rectifier is classified into two types based on the type of i/p power supply. And each kind includes a semi, full and dual converter.

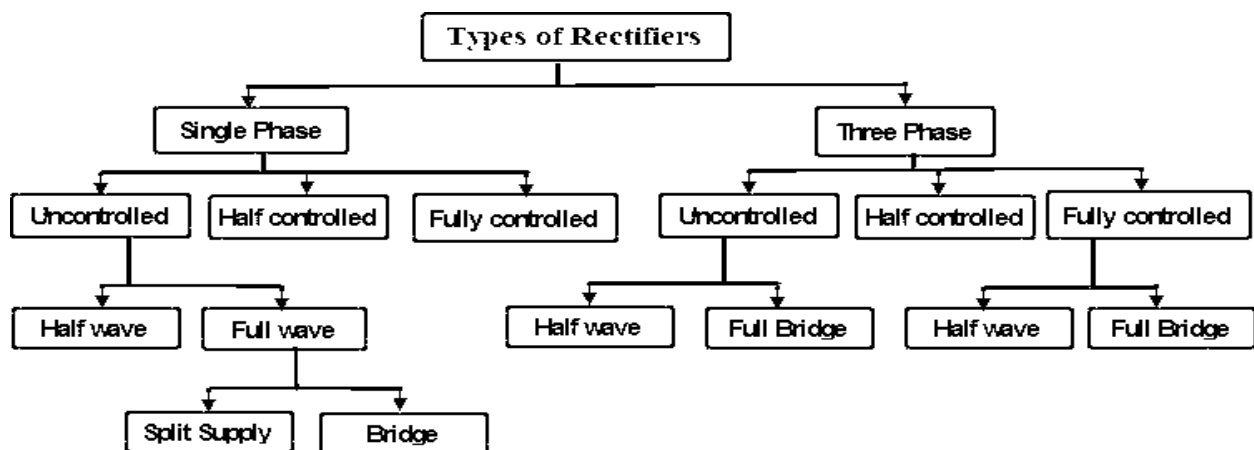

Figure: 2.1. Classification of rectifiers

Single-phase Controlled Rectifier

This type of rectifier which works from single phase AC i/p power supply

Single Phase Controlled Rectifiers are classified into different types

Half wave Controlled Rectifier: This type of rectifier uses a single Thyristor device to provide o/p control only in one half cycle of input AC supply, and it offers low DC output.

Full wave Controlled Rectifier: This type of rectifier provides higher DC output

- Full wave controlled rectifier with a center tapped transformer requires two Thyristors.
- Full wave bridge controlled rectifiers do not need a center tapped transformer

Three-phase Controlled Rectifier

This type of rectifier which works from three phase AC i/p power supply

- A semi converter is a one quadrant converter that has one polarity of o/p voltage and current.
- A full converter is a two quadrants converter that has polarity of o/p voltage can be either +ve or -ve but, the current can have only one polarity that is either +ve or -ve.
- Dual converter works in four quadrants – both o/p voltage and o/p current can have both the polarities.

Operation of Phase Controlled Rectifier

The basic working principle of a PCR circuit is explained using a single phase half wave PCR circuit with a RL load resistive shown in the following circuit.

A single phase half wave Thyristor converter circuit is used to convert AC to DC power conversion. The i/p AC supply is attained from a transformer to offer the required AC supply voltage to the Thyristor converter based on the o/p DC voltage required. In the above circuit, the primary and secondary AC supply voltages are denoted with V_P and V_S .

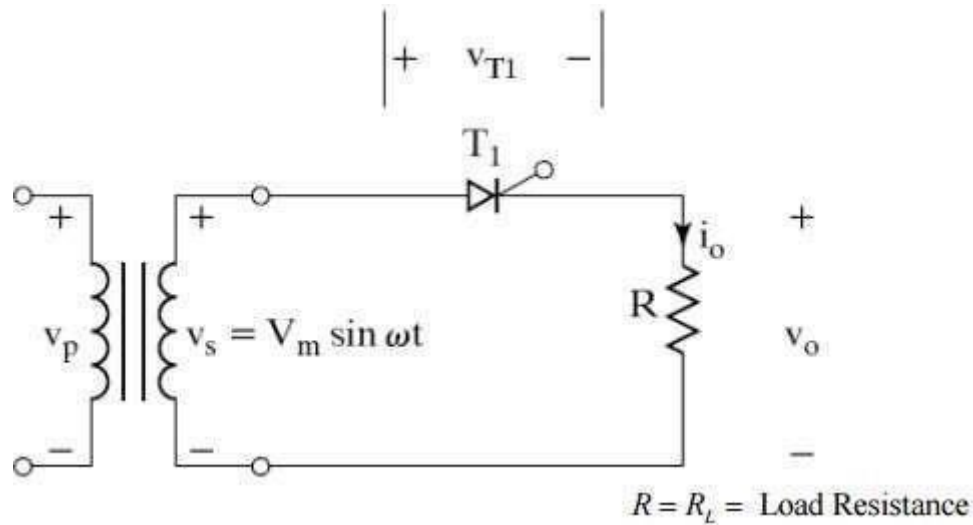

Figure: 2.2. Single phase half wave rectifier circuit

During the +ve half cycle of i/p supply when the upper end of the transformer secondary winding is at a +ve potential with respect to the lower end, the Thyristor is in a forward biased state.

The thyristor is activated at a delay angle of $\omega t = \alpha$, by applying an appropriate gate trigger pulse to the gate terminal of thyristor. When the thyristor is activated at a delay angle of $\omega t = \alpha$, the thyristor behaves and assuming a perfect thyristor. The thyristor acts as a closed switch and the i/p supply voltage acts across the load when it conducts from $\omega t = \alpha$ to π radians. For a purely resistive load, the load current i_o that flows when the thyristor T1 is on, is given by the expression.

$$i_o = v_o / R_L, \text{ for } \alpha \leq \omega t \leq \pi$$

Applications of Phase Controlled Rectifier

Phase controlled rectifier applications include paper mills, textile mills using DC motor drives and DC motor control in steel mills.

- AC fed traction system using a DC traction motor.
- Electro-metallurgical and Electrochemical processes.
- Reactor controls.
- Magnet power supplies.
- Portable hand instrument drives.

- Flexible speed industrial drives.
- Battery charges.
- High voltage DC transmission.
- UPS (Uninterruptible power supply systems).

Operation of half converter with R and RL loads

Single Phase Half Wave Controlled Rectifier with ‘R’ load:

As shown in figure below primary of transformer is connected to ac mains supply with which SCR becomes forward bias in positive half cycle. T1 is triggered at an angle α , T1 conducts and voltage is applied across R.

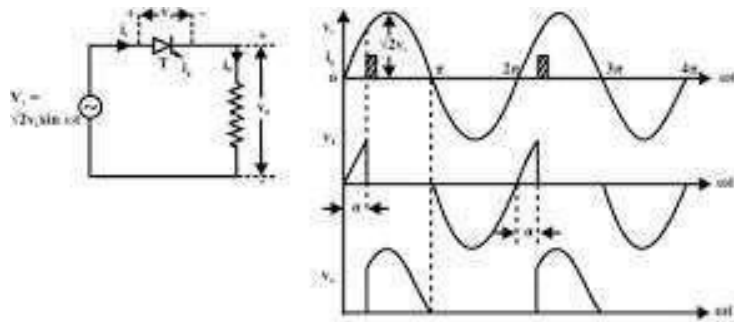

Figure: 2.3 Single phase half wave rectifier with R load with waveforms

The load current i_o flows through ‘R’
the waveforms for voltage & current are as shown above.

As load is resistive,

Output current is given as,

$$I_o = \frac{V_o}{R}$$

Hence shape of output current is same as output voltage

As T1 conducts only in positive half cycle as it is reversed bias in negative cycle, the ripple frequency of output voltage is-

fripple= 50 Hz (supply frequency)

Average output voltage is given as,

$$V_o(Avg) = \frac{1}{T} \int_0^T V_o(\omega t) d\omega t$$

i.e Area under one cycle.

Therefore $T=2\pi$ & $V_o(\omega t) = V_m \sin\omega t$ from α to π & for rest of the period $V_o(\omega t)=0$

$$\begin{aligned} \therefore V_o(Avg) &= \frac{1}{2\pi} \int_0^{2\pi} V_m \sin(\omega t) d\omega t \\ &= \frac{V_m}{2\pi} [-\cos\omega t]_{\alpha}^{\pi} \\ &= \frac{V_m}{2\pi} (1 + \cos\alpha) \end{aligned}$$

Power transferred to load,

$$P_o(Avg) = \frac{V_o^2(Avg)}{R}$$

Thus, power & voltage can be controlled by firing angle.

Single Phase Half Wave Controlled Rectifier with 'RL' load:

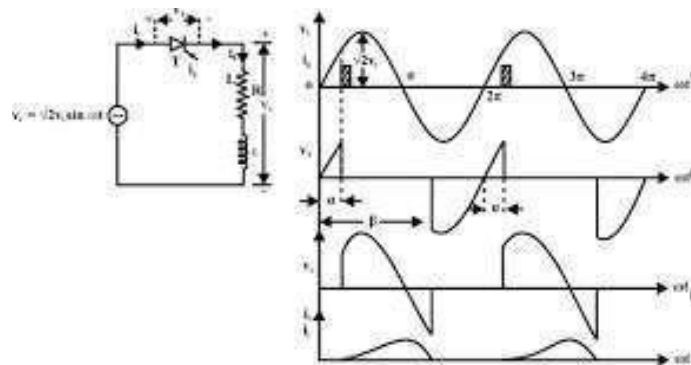

Figure: 2.4 Single phase half wave rectifier with RL load with waveforms

Figure above shows the single phase half wave rectifier with RL Load.

- Normally motors are inductive loads

L= armature of field coil inductance

R= Resistance of coil.

- In positive half cycle, SCR starts conduction at firing angle “ α ”.
- Drop across SCR is small & neglected so output voltage is equal to supply voltage.
- Due to ‘ R_L ’ load, current through SCR increases slowly.
- At ‘ π ’, supply voltage is at zero where load current is at its max value.
- In positive half cycle, inductor stores energy & that generates the voltage.
- In negative half cycle, the voltage developed across inductor, forward biases SCR & maintains its conduction.
- Basically with the property of inductance it opposes change in current.
- Output current & supply current flows in same loop, so all the time $i_o=i_s$.
- After π the energy of inductor is given to mains & there is flow of ‘ i_o ’. The energy reduces as if gets consumed by circuit so current also reduces.
- At ‘ β ’ energy stored in inductance is finished, hence ‘ i_o ’ becomes zero & ‘T1’ turns off.
- ‘ i_o ’ becomes zero from ‘ β ’ to ‘ $2\pi+\alpha$ ’ hence it is discontinuous conduction.

$$\text{The average output voltage } V_0 = \frac{1}{2\pi} \int_{\alpha}^{\beta} V_m \sin \omega t \, d(\omega t) = \frac{V_m}{2\pi} (\beta - \alpha)$$

$$I_0 = \frac{V_0}{2\pi R} (\beta - \alpha)$$

$$\begin{aligned} \text{RMS load voltage } V_0 &= \left\{ \frac{1}{2\pi} \int_{\alpha}^{\beta} V_m^2 \sin^2 \omega t \, d(\omega t) \right\}^{1/2} \\ &= \frac{V_m}{2\sqrt{\pi}} [(\beta - \alpha) - \frac{1}{2} \{\sin 2\beta - \sin 2\alpha\}] \end{aligned}$$

Single phase half controlled converter with RLE load

The diode D2 and D4 conducts for the positive and negative half cycle of the input voltage waveform respectively. On the other hand T1 starts conduction when it is fired in the positive half cycle of the input voltage waveform and continuous conduction till T3 is fired in the negative half cycle. Fig. shows the circuit diagram and the waveforms of a single phase half controlled converter supplying an R – L – E load.

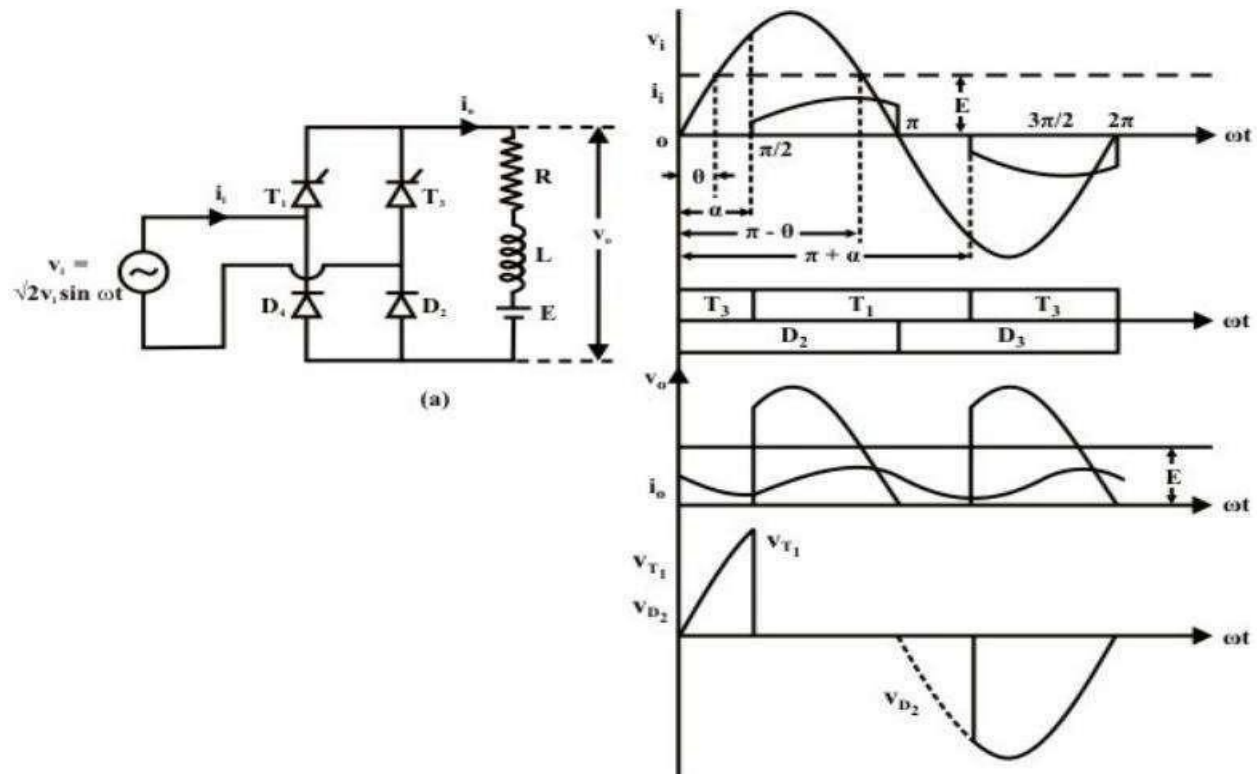

Figure: 2.5 single phase half controlled converter with RLE load

Referring to Fig T1 D2 starts conduction at $\omega t = \alpha$. Output voltage during this period becomes equal to v_i . At $\omega t = \pi$ as v_i tends to go negative D4 is forward biased and the load current commutates from D2 to D4 and freewheels through D4 and T1. The output voltage remains clamped to zero till T3 is fired at $\omega t = \pi + \alpha$. The T3 D4 conduction mode continues upto $\omega t = 2\pi$. Where upon load current again free wheels through T3 and D2 while the load voltage is clamped to zero. From the discussion in the previous paragraph it can be concluded that the output voltage (hence the output current) is periodic over half the input cycle. Hence

$$V_{oav} = \frac{1}{\pi} \int_0^{\pi} v_o d\omega t = \frac{1}{\pi} \int_{\alpha}^{\pi} \sqrt{2}V_i \sin \omega t d\omega t = \frac{\sqrt{2}V_i}{\pi} (1 + \cos\alpha)$$

$$I_{ov} = \frac{V_{oav} - E}{R} = \frac{\sqrt{2}V_i}{\pi R} (1 + \cos\alpha - \pi \sin\theta)$$

Single phase half controlled converter with RLE load and freewheeling diode

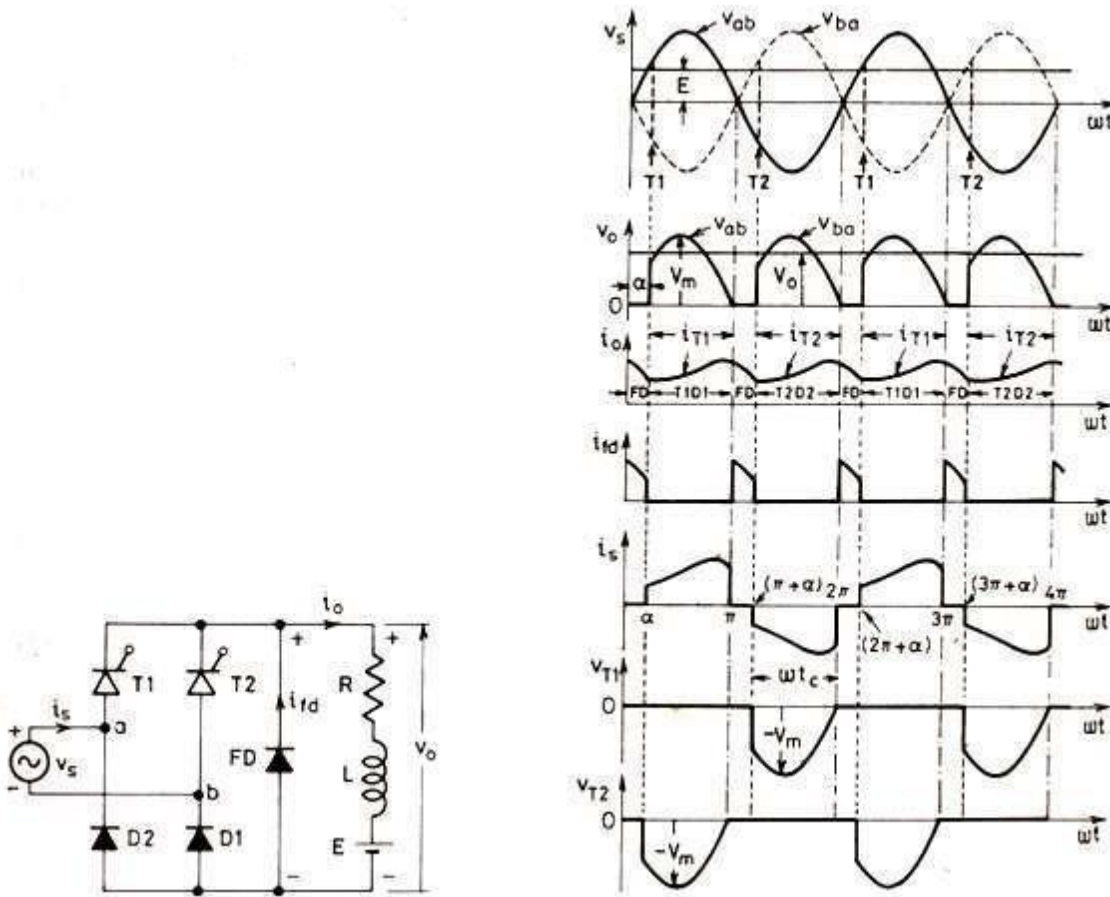

Figure: 2.6 single phase half controlled converter with RLE load and freewheeling diode

Numerical problems

1. A single phase 230V, 1 Kwheater is connected across 1 phase 230V, 50Hz supply through an SCR. For firing angle delay of 45° and 90°, calculate the power absorbed in the heater element.

Solution: Heater resistance $R = 230^2/1000 \Omega$

The rms value of voltage is $V_{or} = \frac{V_m}{2\sqrt{\pi}} [(\pi - \alpha) + \frac{1}{2} \sin 2\alpha]^{1/2}$

$$= \frac{\sqrt{2} \times 230}{2\sqrt{\pi}} [(\pi - \frac{\pi}{4}) + \frac{1}{2} \sin 90]^{1/2} = 155.071V$$

Power absorbed by the heater element for $\alpha = 45^\circ$ is

$$\frac{V_{or}^2}{R} = \left[\frac{155.071}{230} \right]^2 \times 1000 = 454.57W$$

for $\alpha = 90^\circ$ the rms voltage is

$$V_{or} = \frac{\sqrt{2} \times 230}{2\sqrt{\pi}} [(\pi - \frac{\pi}{2}) + \frac{1}{2} \sin 180]^{1/2} = 115V$$

Power absorbed by the heater element for $\alpha = 90^\circ$ is

$$\frac{V_{or}^2}{R} = \left[\frac{115}{230} \right]^2 \times 1000 = 250W$$

2. A resistive load of 10Ω is connected through a half-wave controlled rectifier circuit to 220V, 50 Hz, single phase source. Calculate the power delivered to the load for a firing angle of 60° . Find also the value of input power factor
3. A single phase semi converter delivers to RLE load with $R=5\Omega$, $L = 10mH$ and $E = 80V$. The source voltage is 230V, 50Hz. For continuous conduction, Find the average value of output current for firing angle = 50° .

Single phase full wave controlled rectifier

Single Phase Full Wave Controlled Rectifier with 'R' load:

Figure below shows the Single phase Full Wave Controlled Rectifiers with R load

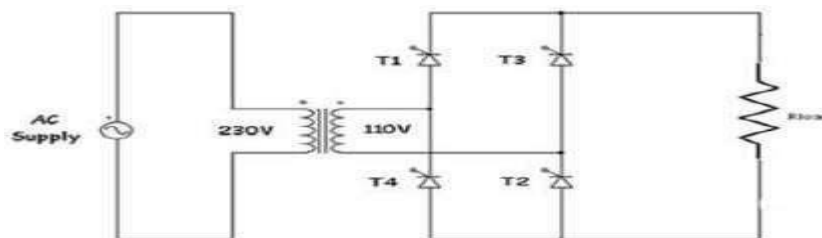

Figure: 2.7 single phase full converter circuit with R load

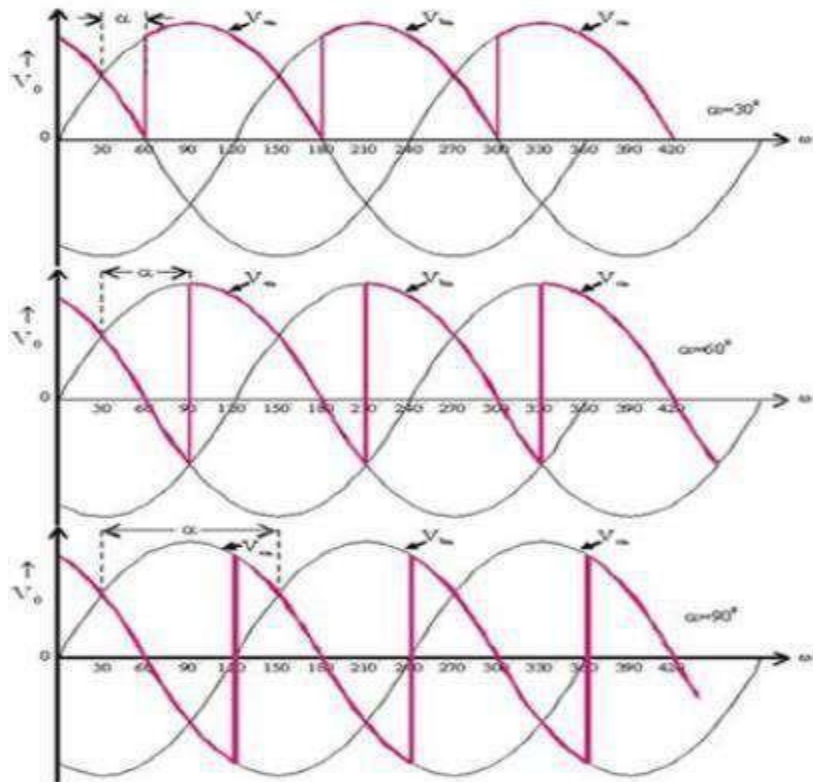

Figure: 2.8 single phase full converter circuit with R load input and output waveforms

- The single phase fully controlled rectifier allows conversion of single phase AC into DC. Normally this is used in various applications such as battery charging, speed control of DC motors and front end of UPS (Uninterruptible Power Supply) and SMPS (Switched Mode Power Supply).

- All four devices used are Thyristors. The turn-on instants of these devices are dependent on the firing signals that are given. Turn-off happens when the current through the device reaches zero and it is reverse biased at least for duration equal to the turn-off time of the device specified in the data sheet.

- In positive half cycle Thyristors T1 & T2 are fired at an angle α .

- When T1 & T2 conducts

$$V_o = V_s$$

$$I_o = i_s = V_o / R = V_s / R$$

- In negative half cycle of input voltage, SCR's T3 & T4 are triggered at an angle of $(\pi + \alpha)$

- Here output current & supply current are in opposite direction

$$\therefore i_s = -i_o$$

T3 & T4 becomes off at 2π .

$$V = \frac{1}{\pi} \int_{\alpha}^{\pi+\alpha} V_m \sin \omega t \, d(\omega t) = \frac{2V_m}{\pi} \cos \alpha$$

Single Phase Full Wave Controlled Rectifier with 'RL' load:

Figure below shows Single phase Full Wave Controlled Rectifiers with RL load.

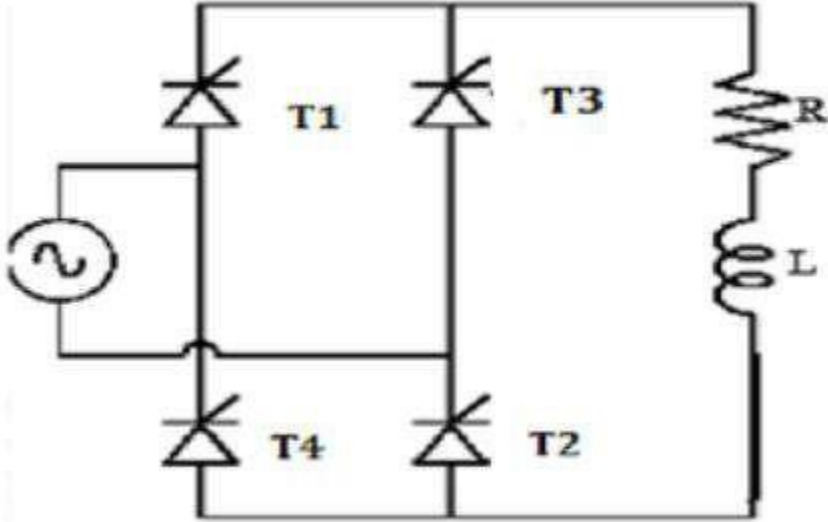

Figure: 2.9 single phase full converter circuit with RL load

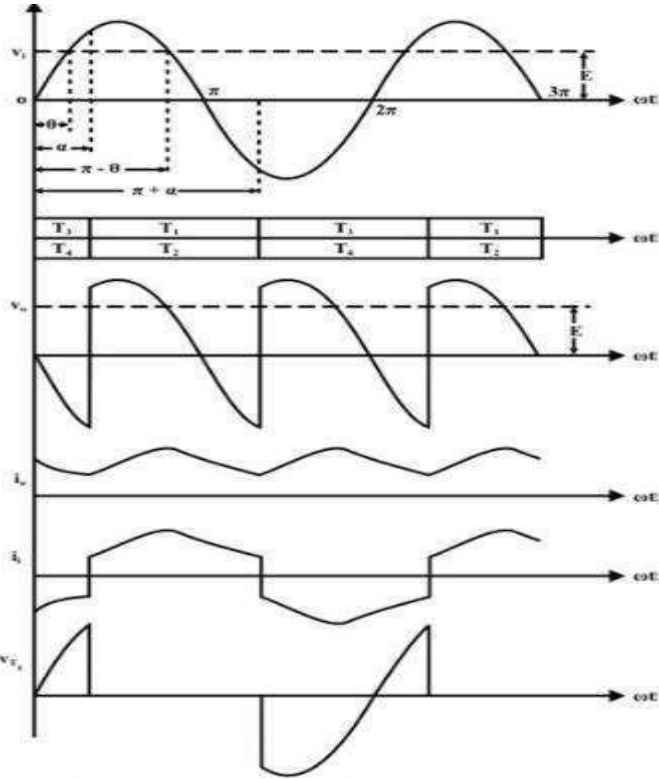

Figure: 2.10 single phase full converter circuit with RL load input and output waveforms

Operation of this mode can be divided between four modes

Mode 1 (α to π)

- In positive half cycle of applied ac signal, SCR's T1 & T2 are forward bias & can be turned on at an angle α .
- Load voltage is equal to positive instantaneous ac supply voltage. The load current is positive, ripple free, constant and equal to I_o .
- Due to positive polarity of load voltage & load current, load inductance will store energy.

Mode 2 (π to $\pi+\alpha$)

- At $\omega t = \pi$, input supply is equal to zero & after π it becomes negative. But inductance opposes any change through it.
- In order to maintain a constant load current & also in same direction. A self induced emf appears across 'L' as shown.
- Due to this induced voltage, SCR's T1 & T2 are forward bias in spite the negative supply voltage.
- The load voltage is negative & equal to instantaneous ac supply voltage whereas load current is positive.
- Thus, load acts as source & stored energy in inductance is returned back to the ac supply.

Mode 3 ($\pi+\alpha$ to 2π)

- At $\omega t = \pi + \alpha$ SCR's T3 & T4 are turned on & T1, T2 are reversed bias.
- Thus, process of conduction is transferred from T1, T2 to T3, T4.
- Load voltage again becomes positive & energy is stored in inductor
- T3, T4 conduct in negative half cycle from $(\pi + \alpha)$ to 2π
- With positive load voltage & load current energy gets stored

Mode 4 (2π to $2\pi+\alpha$)

- At $\omega t = 2\pi$, input voltage passes through zero.
- Inductive load will try to oppose any change in current if in order to maintain load current constant & in the same direction.
- Induced emf is positive & maintains conducting SCR's T3 & T4 with reverse polarity also.

- Thus VL is negative & equal to instantaneous ac supply voltage. Whereas load current continues to be positive.
- Thus load acts as source & stored energy in inductance is returned back to ac supply
- At $\omega t = \alpha$ or $2\pi + \alpha$, T3 & T4 are commutated and T1, T2 are turned on.

$$V = \frac{1}{\pi} \int_{\alpha}^{\pi+\alpha} V_m \sin \omega t d(\omega t) = \frac{2V_m}{\pi} \cos \alpha$$

Single phase fully controlled converters with RLE load

The circuit diagram of a full wave bridge rectifier using thyristors is shown in figure below. It consists of four SCRs which are connected between single phase AC supply and a load.

This rectifier produces controllable DC by varying conduction of all SCRs.

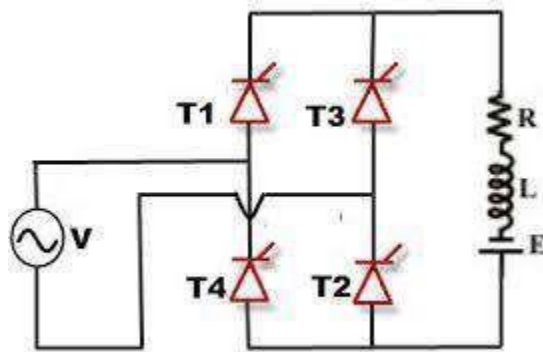

Figure: 2.11 single phase full converter circuit with RLE load

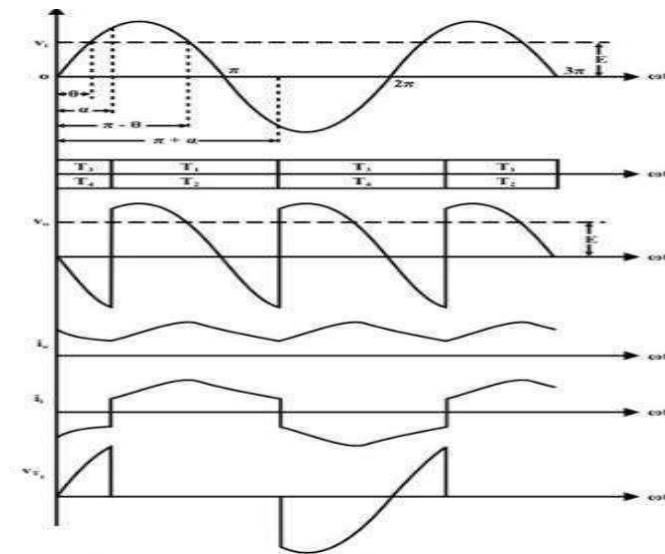

Figure: 2.12 single phase full converter circuit with RLE load input and output waveforms

In positive half-cycle of the input, Thyristors T1 and T2 are forward biased while T3 and T4 are reverse biased. Thyristors T1 and T2 are triggered simultaneously at some firing angle in the positive half cycle, and T3 and T4 are triggered in the negative half cycle.

The load current starts flowing through them when they are in conduction state. The load for this converter can be RL or RLE depending on the application.

By varying the conduction of each thyristor in the bridge, the average output of this converter gets controlled. The average value of the output voltage is twice that of half-wave rectifier.

The average output voltage is

$$V_{oavg} = \frac{1}{\pi} \int_{\alpha}^{\pi+\alpha} V_m \sin wt \, d(wt) = \frac{2V_m}{\pi} \cos \alpha$$

Line commutated converters

For single phase half wave converter

1. Average DC load voltage: (V_{oavg})

$$\begin{aligned} V_{oavg} &= V_{oavg} = \frac{1}{T} \int_0^T V_m \sin wt \, d(wt) \text{ where T is time period} \\ V_{oavg} &= \frac{1}{2\pi} \left[\int_{\alpha}^{\pi} V_m \sin wt \, d(wt) + \int_{\pi}^{2\pi+\alpha} 0 \, d(wt) \right] \\ &= \frac{1}{2\pi} \left[\int_{\alpha}^{\pi} V_m \sin wt \, d(wt) \right] \\ &= \frac{V_m}{2\pi} [-\cos wt]_{\alpha}^{\pi} \\ &= \frac{V_m}{2\pi} [-\cos \pi + \cos \alpha] \\ &= \frac{V_m}{2\pi} [1 + \cos \alpha] \end{aligned}$$

$$\text{If } \alpha = 0 \quad V_{oavg \max} = \frac{V_m}{\pi}$$

$$\text{If } \alpha = 180 \quad V_{oavg} = 0$$

2. Average DC load current is given as

$$I_{oavg} = \frac{V_{oavg}}{R}$$

$$I_{\text{avg}} = \frac{V_m}{2\pi R} [1 + \cos\alpha]$$

3. RMS load voltage

$$V_{\text{rms}} = \sqrt{\frac{1}{T} \int_0^{2\pi} V_m \sin^2 \omega t \, d(\omega t)}$$

$$V_{\text{rms}} = \sqrt{\frac{1}{2\pi} \int_{\alpha}^{\pi} V_m^2 \sin^2 \omega t \, d(\omega t)}$$

$$V_{\text{rms}} = \frac{V_m}{2\sqrt{\pi}} \left[(\pi - \alpha) + \frac{1}{2} \sin 2\alpha \right]^{1/2}$$

If $\alpha = 0$ $V_{\text{rms}} = \frac{V_m}{2}$

If $\alpha = 180$ $V_{\text{rms}} = 0$

The RMS voltage may be varied from 0 to $\frac{V_m}{2}$ by varying α from 180 to 0

4. Power delivered to the resistive load is given

$$\begin{aligned} P_L &= (\text{RMS load voltage})(\text{RMS load current}) \\ &= V_{\text{rms}} I_{\text{rms}} \\ &= \frac{V_{\text{rms}}^2}{R} = I_{\text{rms}}^2 R \end{aligned}$$

5. Input volt amperes = (RMS source voltage)(RMS line current)

$$\begin{aligned} &= V_s I_{\text{rms}} \\ &= \frac{V_s \sqrt{2} V_s}{R 2 \sqrt{\pi}} \left[(\pi - \alpha) + \frac{1}{2} \sin 2\alpha \right]^{1/2} \\ &= \frac{V_s^2}{\sqrt{2\pi} R} \left[(\pi - \alpha) + \frac{1}{2} \sin 2\alpha \right]^{1/2} \end{aligned}$$

6. Input power factor: It is defined as the ratio of total mean input power to the total rms input volt amperes

$$\begin{aligned} \text{Input power factor} &= \frac{\frac{\sqrt{2}V_s}{2\sqrt{\pi}} [(\pi-\alpha) + \frac{1}{2}\sin 2\alpha]^{1/2}}{V_s} \\ &= \frac{1}{\sqrt{2\pi}} \left[\pi - \alpha + \frac{1}{2}\sin 2\alpha \right]^{1/2} \end{aligned}$$

7. Form factor: Form factor is defined as the ratio of RMS voltage to the average DC voltage

$$\text{Form Factor} = \frac{V_{rms}}{V_{avg}}$$

8. Effective value of the AC component of the output voltage

$$V_{ac} = [V_{rms}^2 - V_{avg}^2]^{1/2}$$

9. Ripple factor (R_f)

It is defined as the ratio of AC component to the DC. Where ripple is the amount of AC component present in DC component

$$R_f = \frac{V_{ac}}{V_{avg}} = \frac{[V_{rms}^2 - V_{avg}^2]^{1/2}}{V_{avg}} = \left[\left(\frac{V_{rms}}{V_{avg}} \right)^2 - 1 \right]^{1/2} = \sqrt{FF^2 - 1}$$

10. Transformer Utilization Factor (TUF):

It is defined as the ratio of output DC power to the volt ampere rating of the transformer

$$\text{TUF} = \frac{P_{dc}}{\text{VA rating of secondary winding of the transformer}}$$

11. Rectifier efficiency:

It is defined as the ratio of output DC power to the input ac power

$$\eta = \frac{V_{avg} I_{avg}}{V_{rms} I_{rms}}$$

12. Peak inverse voltage (PIV):

It is defined as the maximum voltage that an SCR can be subjected to in the reverse biased condition

In the case of Half wave rectifier it is V_m

Effect of source inductance in single phase rectifier

Fig. below shows a single phase fully controlled converter with source inductance. For simplicity it has been assumed that the converter operates in the continuous conduction mode. Further, it has been assumed that the load current ripple is negligible and the load can be replaced by a dc current source the magnitude of which equals the average load current. Fig. shows the corresponding waveforms

It is assumed that the Thyristors T3 and T4 were conducting at $t = 0$. T1 and T2 are fired at $\omega t = \alpha$. If there were no source inductance T3 and T4 would have commutated as soon as T1 and T2 are turned ON.

The input current polarity would have changed instantaneously. However, if a source inductance is present the commutation and change of input current polarity cannot be instantaneous. Therefore, when T1 and T2 are turned ON T3 T4 does not commutate immediately. Instead, for some interval all four Thyristors continue to conduct as shown in Fig. 2.14. This interval is called “overlap” interval.

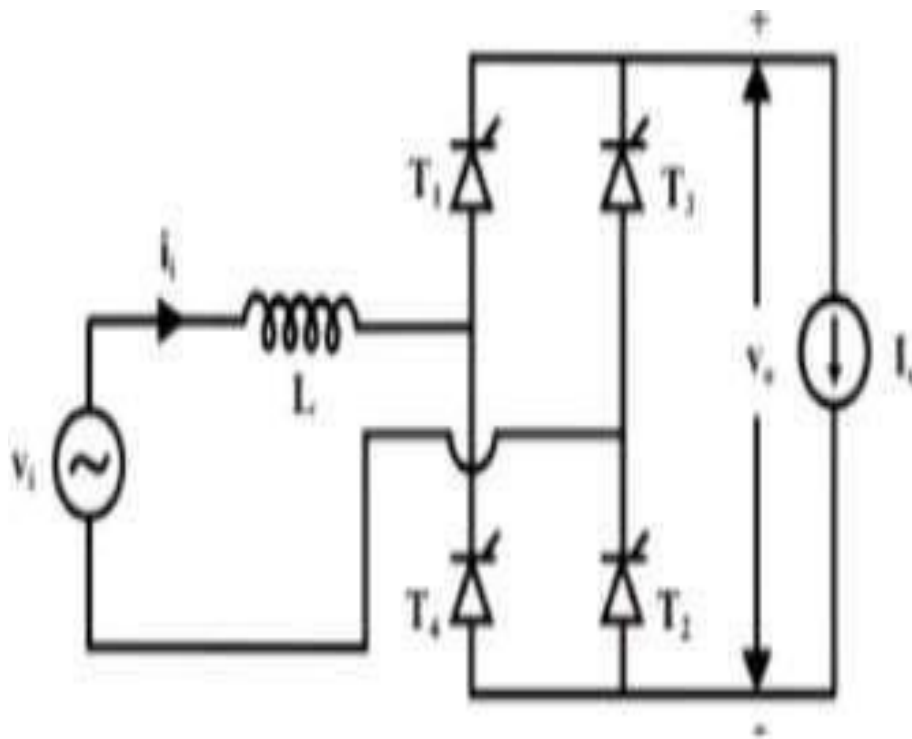

Figure: 2.13 single phase full converter circuit with source inductance

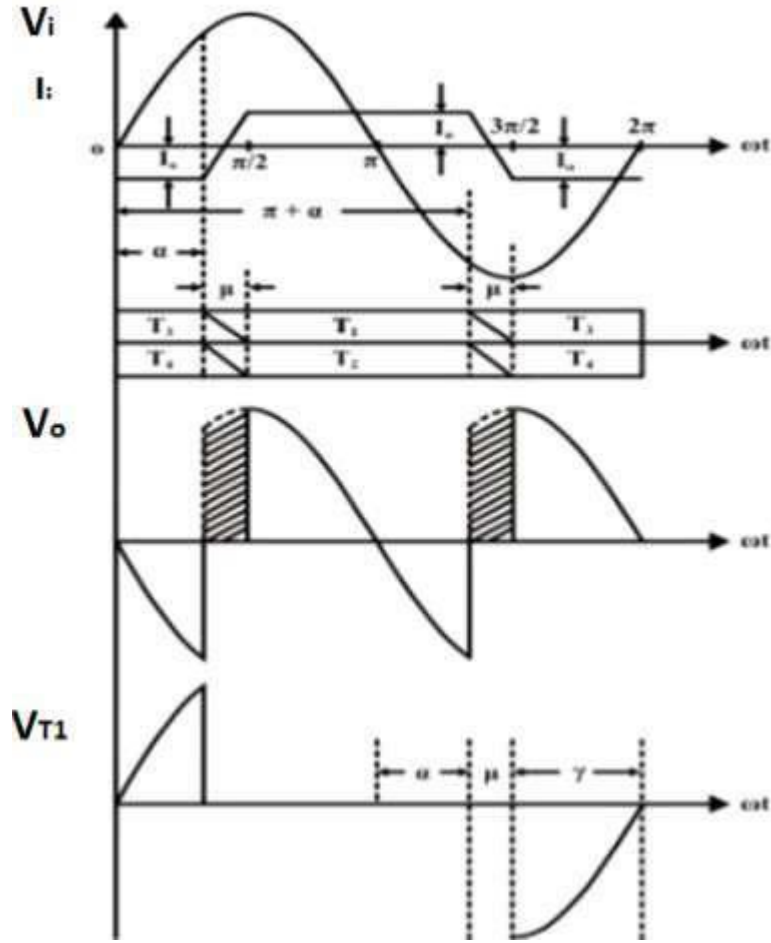

Figure: 2.14 single phase full converter output waveforms with source inductance

1. During overlap interval the load current freewheels through the thyristors and the output voltage is clamped to zero. On the other hand, the input current starts changing polarity as the current through T1 and T2 increases and T3 T4 current decreases. At the end of the overlap interval the current through T3 and T4 becomes zero and they commute, T1 and T2 starts conducting the full load current
2. The same process repeats during commutation from T1 T2 to T3T4 at $\omega t = \pi + \alpha$. From Fig. 2.14 it is clear that, commutation overlap not only reduces average output dc voltage but also reduces the extinction angle γ which may cause commutation failure in the inverting mode of operation if α is very close to 180° .
3. In the following analysis an expression of the overlap angle " μ " will be determined. From the equivalent circuit of the converter during overlap period.

$$L \frac{di_i}{dt} = v_i \text{ for } \alpha \leq \omega t + \mu$$

$$i_i(\omega t = \alpha) = -I_0$$

$$i_i = I - \frac{\sqrt{2}V_i}{\omega L} \cos \omega t$$

$$\therefore i_i|_{\omega t = \alpha} = I - \frac{\sqrt{2}V_i}{\omega L} \cos \alpha = -I_0$$

$$I = \frac{\sqrt{2}V_i}{\omega L} \cos \alpha - I_0$$

$$\therefore i_i = \frac{\sqrt{2}V_i}{\omega L} (\cos \alpha - \cos \omega t) - I_0$$

$$\text{at } \omega t = \alpha + \mu \quad i_i = I_0$$

$$I_0 = \frac{\sqrt{2}V_i}{\omega L} (\cos \alpha - \cos(\alpha + \mu)) - I_0$$

$$\therefore \cos \alpha - \cos(\alpha + \mu) = \frac{\sqrt{2}\omega L}{V_0} I_0$$

$$V_0 = \frac{I}{\pi} \int_{\alpha}^{\alpha+\mu} V_i d\omega t$$

$$\text{or } V_0 = \frac{I}{\pi} \int_{\alpha+\mu}^{\alpha+\pi} \sqrt{2}v_i \sin \omega t d\omega t$$

$$= \frac{\sqrt{2}v_i}{\pi} [\cos(\alpha + \mu) - \cos(\pi + \alpha)]$$

$$= \frac{\sqrt{2}v_i}{\pi} [\cos \alpha + \cos(\alpha + \mu)]$$

$$\therefore V_0 = 2\sqrt{2} \frac{v_i}{\pi} [\cos \alpha - \cos(\alpha + \mu)]$$

$$\therefore V_0 = \frac{2\sqrt{2}}{\pi} v_i \cos \alpha - \frac{2}{\pi} \omega L I_0$$

The Equation can be represented by the following equivalent circuit

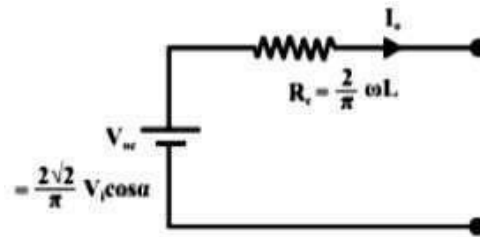

Figure: 2.15 Equivalent circuit of the given equation

Equivalent circuit representation of the single phase fully controlled rectifier with source inductance

The simple equivalent circuit of Fig. 2.15 represents the single phase fully controlled converter with source inductance as a practical dc source as far as its average behavior is concerned. The open circuit voltage of this practical source equals the average dc output voltage of an ideal converter (without source inductance) operating at a firing angle of α . The voltage drop across the internal resistance “RC” represents the voltage lost due to overlap shown in Fig. 2.14 by the hatched portion of the V_o waveform. Therefore, this is called the “Commutation resistance”. Although this resistance accounts for the voltage drop correctly there is no power loss associated with this resistance since the physical process of overlap does not involve any power loss. Therefore this resistance should be used carefully where power calculation is involved.

Numerical problems

1. For the single phase fully controlled bridge is connected to RLE load. The source voltage is 230 V, 50 Hz. The average load current of 10A continuous over the working range. For $R= 0.4 \Omega$ and $L = 2\text{mH}$, Compute (a) firing angle for $E = 120\text{V}$ (b) firing angle for $E = -120\text{V}$ (c) in case output current is constant find the input power factors for both parts a and b

Solution:

- a) For $E = 120$ the full converter is operating as a controlled rectifier

$$\frac{2V_m}{\pi} \cos\alpha = E + I_d R_c$$

$$\frac{2\sqrt{2} \cdot 230}{\pi} \cos\alpha = 120 + 10 \times 0.4 = 124\text{V}$$

$$\alpha = 53.21^\circ$$

For $\alpha = 53.21^\circ$ power flows from ac source to DC load.

b) For $E = -120$ the full converter is operating as a controlled rectifier

$$\frac{2V_m}{\pi} \cos\alpha = E + I_o R$$

$$\frac{2\sqrt{2} \cdot 230}{\pi} \cos\alpha = -120 + 10 \times 0.4 = -116V$$

$$\alpha = 124.1^\circ$$

For $\alpha = 124.1^\circ$ power flows from DC source to ac load.

c) For constant load current, rms value of load current is

$$I_{or} = I_o = 10A$$

$$V_s I_{or} \cos\Phi = EI_o + I_o^2 R$$

For $\alpha = 53.21^\circ$

$$\cos\Phi = \frac{120 \times 10 + 10^2 \times 0.4}{230 \times 10} = 0.5391 \text{ lag}$$

For $\alpha = 124.1^\circ$

$$\cos\Phi = \frac{120 \times 10 - 10^2 \times 0.4}{230 \times 10} = 0.5043 \text{ lag}$$

2. A single phase two pulse converter feeds power to RLE load with $R = 6\Omega$, $L = 6mH$, $E = 60V$, AC source voltage is $230V$, $50Hz$ for continuous condition. Find the average value of load current for a firing angle of 50° . In case one of the 4 SCRs gets open circuited. Find the new value of average load current assuming the output current as continuous.
3. For the single phase fully controlled bridge converter having load of 'R', determine the average output voltage, rms output voltage and input power factor if the supply is $230V$, $50Hz$, single phase AC and the firing angle is 60 degrees

Operation of three phase half wave rectifier with R and RL loads

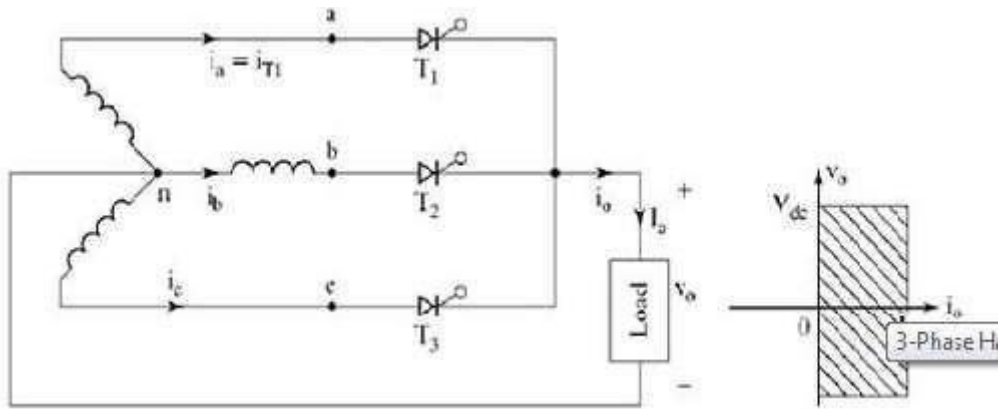

Figure: 2.16 circuit diagram three phase half wave rectifier

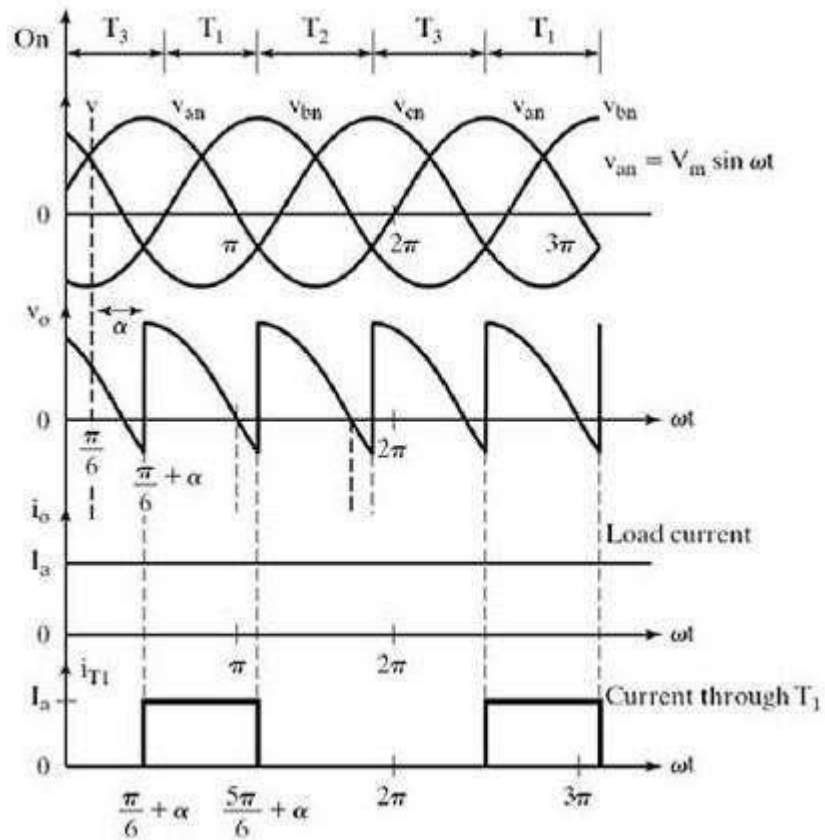

Figure: 2.17 input and output waveforms of three phase half wave rectifier

Three phase supply voltage equations

We define three line neutral voltages (3 phase voltages) as follows

$V_{RN} = V_{an} = V_m \sin \omega t$ where V_m is the maximum voltage

$$V_{YN} = V_{bn} = V_m \sin \left(\omega t - \frac{2\pi}{3} \right)$$

$$V_{BN} = V_{cn} = V_m \sin \left(\omega t - \frac{4\pi}{3} \right)$$

The **3-phase half wave converter** combines three **single phase half wave controlled rectifiers in one** single circuit feeding a common load. The thyristor T_1 in series with one of the supply phase windings ' $a-n$ ' acts as one half wave controlled rectifier. The second thyristor T_2 in series with the supply phase winding ' $b-n$ ' acts as the second half wave controlled rectifier. The third thyristor T_3 in series with the supply phase winding acts as the third half wave controlled rectifier.

The 3-phase input supply is applied through the star connected supply transformer as shown in the figure. The common neutral point of the supply is connected to one end of the load while the other end of the load connected to the common cathode point.

When the thyristor T_1 is triggered at $\omega t = (\pi/6 + \alpha) = (30^\circ + \alpha)$, the phase voltage V_{an} appears across the load when T_1 conducts. The load current flows through the supply phase winding ' $a-n$ ' and through thyristor T_1 as long as T_1 conducts.

When thyristor T_2 is triggered at $\omega t = (5\pi/6 + \alpha)$, T_1 becomes reverse biased and turns-off. The load current flows through the thyristor and through the supply phase winding ' $b-n$ '. When T_2 conducts the phase voltage v_{bn} appears across the load until the thyristor T_3 is triggered.

When the thyristor T_3 is triggered at $\omega t = (3\pi/2 + \alpha) = (270^\circ + \alpha)$, T_2 is reversed biased and hence T_2 turns-off. The phase voltage V_{an} appears across the load when T_3 conducts.

When T_1 is triggered again at the beginning of the next input cycle the thyristor T_3 turns off as it is reverse biased naturally as soon as T_1 is triggered. The figure shows the 3-phase input supply voltages, the output voltage which appears across the load, and the load current assuming a constant and ripple free load current for a highly inductive load and the current through the thyristor T_1 .

For a purely resistive load where the load inductance ' $L = 0$ ' and the trigger angle $\alpha > (\pi/6)$, the load current appears as discontinuous load current and each thyristor is naturally commutated when the polarity of the corresponding phase supply voltage reverses. The frequency of output

ripple frequency for a **3-phase half wave converter** is f_s , where f_s is the input supply frequency.

3

The **3-phase half wave converter** is not normally used in practical converter systems because of the disadvantage that the supply current waveforms contain dc components (i.e., the supply current waveforms have an average or dc value).

To derive an expression for the average output voltage of a 3-phase half wave converter for continuous load current

The reference phase voltage is $v_{RN}=v_{an}=V_m \sin \omega t$. The trigger angle is measured from the cross over points of the 3-phase supply voltage waveforms. When the phase supply voltage V_{an} begins its positive half cycle at $\omega t=0$, the first cross over point appears at $\omega t=(\pi/6)$ radians 30° .

The trigger angle α for the thyristor T_1 is measured from the cross over point at $\pi/6$. The thyristor T_1 is forward biased during the period $\omega t=30^\circ$ to 150° , when the phase supply voltage v_{an} has higher amplitude than the other phase supply voltages. Hence T_1 can be triggered between 30° to 150° . When the thyristor T_1 is triggered at a trigger angle α , the average or dc output voltage for continuous load current is calculated using the equation

$$\begin{aligned}
 V_{avg} &= \frac{3}{2\pi} \int_{\pi/6+\alpha}^{5\pi/6+\alpha} V_m \sin \omega t d(\omega t) \\
 &= \frac{3V_m}{2\pi} \left[(-\cos \alpha) \frac{6}{\pi+\alpha} \right] \\
 &= \frac{3\sqrt{3}V_m}{2\pi} \cos \alpha \\
 &= \frac{3V_m}{2\pi} \cos \alpha
 \end{aligned}$$

Operation of three phase half controlled rectifier with R and RL loads

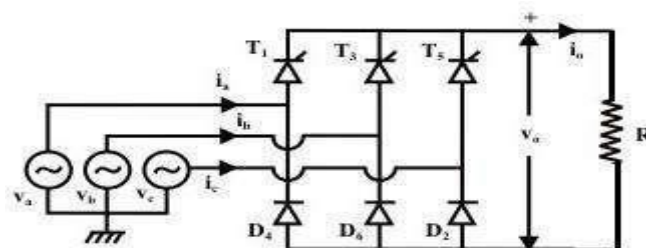

Figure: 2.18 circuit diagram three phase half controlled rectifier

Three phase half wave controlled rectifier output voltage waveforms for different trigger angles with R load

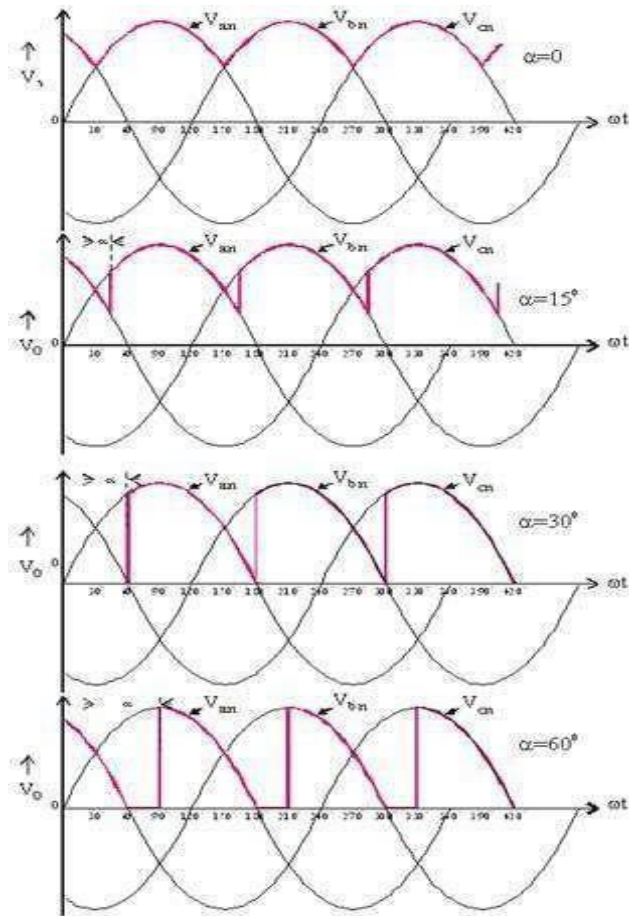

Figure: 2.19 input and output waveforms of three phase half controlled rectifier with R load

Three single phase half wave converters can be connected to form a three phase half wave converter. Similarly three phase semi converter uses 3 SCRs T_1, T_3 & T_5 and 3 diodes D_2, D_4 & D_6 In the circuit shown above when any device conducts, line voltage is applied across load. so line voltage are necessary to draw Phase shift between two line voltages is 60 degree & between two phase voltages it is 120 degree Each phase & line voltage is sine wave with the frequency of 50 Hz. R,Y,B are phase voltages with respect to 'N'.

In the case of a **three-phase half wave controlled** rectifier with resistive load, the thyristor T_1 is triggered at $\omega t = (30^\circ + \alpha)$ and T_1 conducts up to $\omega t = 180^\circ = \pi$ radians. When the phase supply voltage decreases to zero at $\omega t = 180^\circ$, the load current falls to zero and the thyristor T_1 turns off. Thus T_1 conducts from $\omega t = (30^\circ + \alpha)$ to (180°) .

Hence the average dc output voltage for a 3-pulse converter (3-phase half wave controlled rectifier) is calculated by using the equation

$$\begin{aligned}
 \text{The average output voltage } V_{\text{avg}} &= \frac{3}{2\pi} \int_{\frac{2\pi}{3}-\alpha}^{\frac{2\pi}{3}} V_m \sin \omega t \, d(\omega t) + \int_{\frac{2\pi}{3}}^{\frac{2\pi}{3}+\alpha} V_m \sin \omega t \, d(\omega t) \\
 &= \frac{3V_m}{2\pi} (1 + \cos \alpha)
 \end{aligned}$$

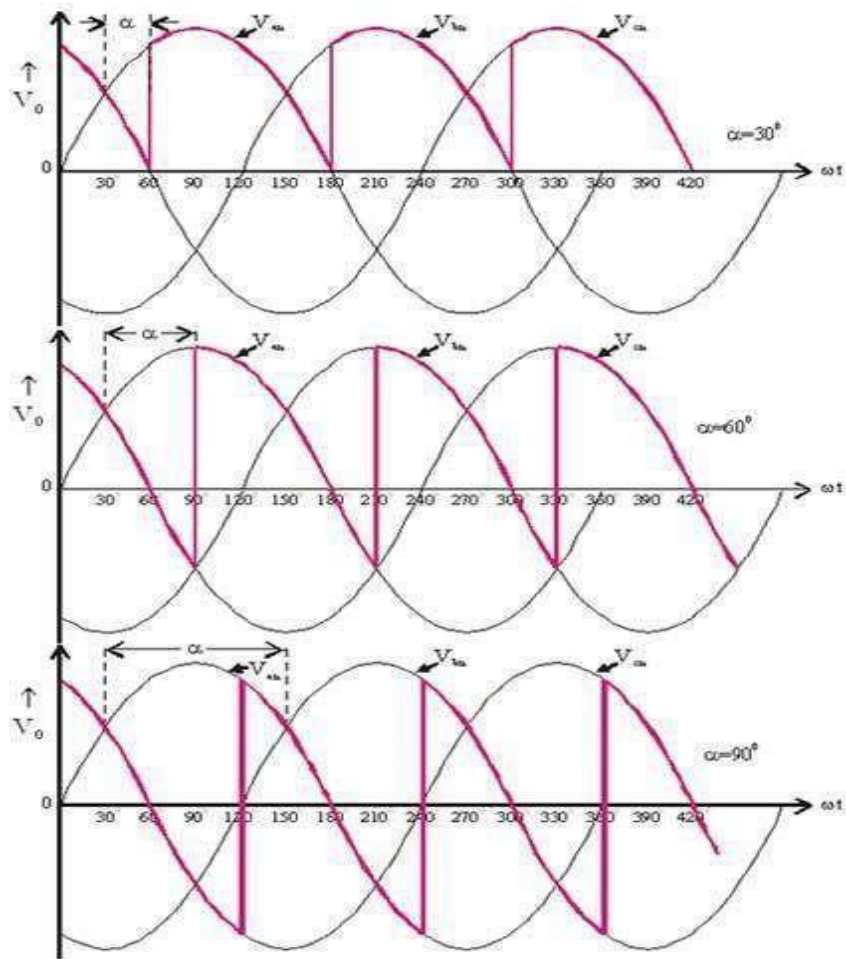

Figure: 2.19 Input and output waveforms of three phase half controlled rectifier with RL load

Numerical Problems on three phase rectifiers:

1. A three phase semi converter feeds power to a resistive load of 10Ω . For a firing angle delay of 30° the load takes 5 Kw. Find the magnitude of per phase input supply voltage.

Solution:

$$V_{or} = \frac{3}{2\pi} \left[\int_{\pi}^{\pi+\alpha} V_m \sin^2 \omega t \, d(\omega t) + \int_{\pi+\alpha}^{2\pi} V_m \sin^2 \omega t \, d(\omega t) \right]$$

$$V_{or}^2 = \frac{3V_m^2}{4\pi} \left[\left| \omega t + \frac{\sin 2\omega t}{2} \right|_{\pi}^{\pi+\alpha} + \left| \omega t + \frac{\sin 2\omega t}{2} \right|_{\pi+\alpha}^{2\pi} \right]$$

$$V_{or} = \frac{V_m}{\sqrt{2}} \left[\frac{2\pi}{\pi} + \frac{\sqrt{3}}{3} (1 + \cos 2\alpha) \right]^{1/2}$$

For $\alpha = 30^\circ$

$$P = V^2/R$$

$$5000 \times 10 = \frac{2V_s^2}{4} \left[\frac{2\pi}{\pi} + \frac{\sqrt{3}}{3} (1 + \cos 60) \right]$$

$$V_s = 175.67V \text{ and } V_{ph} = 101.43V$$

2. A three-phase half-wave controlled rectifier has a supply of 200V/phase. Determine the average load voltage for firing angle of 0° , 30° and 60° assuming a thyristor volt drop of 1.5V and continuous load current
3. A three phase half wave converter is supplying a load with a continuous constant current of 50A over a firing angle from 0° to 60° . What will be the power dissipated by the load at these limiting values of firing angle. The supply voltage is 415V (line).

Operation of three phase fully controlled rectifier with R and RL loads

Three phase full converter is a fully controlled bridge controlled rectifier using six thyristors connected in the form of a full wave bridge configuration. All the six thyristors are controlled switches which are turned on at a appropriate times by applying suitable gate trigger signals.

The **three phase full converter** is extensively used in industrial power applications upto about 120kW output power level, where two quadrant operations is required. The figure shows a **three phase full converter** with highly inductive load. This circuit is also known as three phase full wave bridge or as a six pulse converter.

The thyristors are triggered at an interval of $(\pi/3)$ radians (i.e. at an interval of 30°). The frequency of output ripple voltage is $6f_s$ and the filtering requirement is less than that of **three phase semi and half wave converters**.

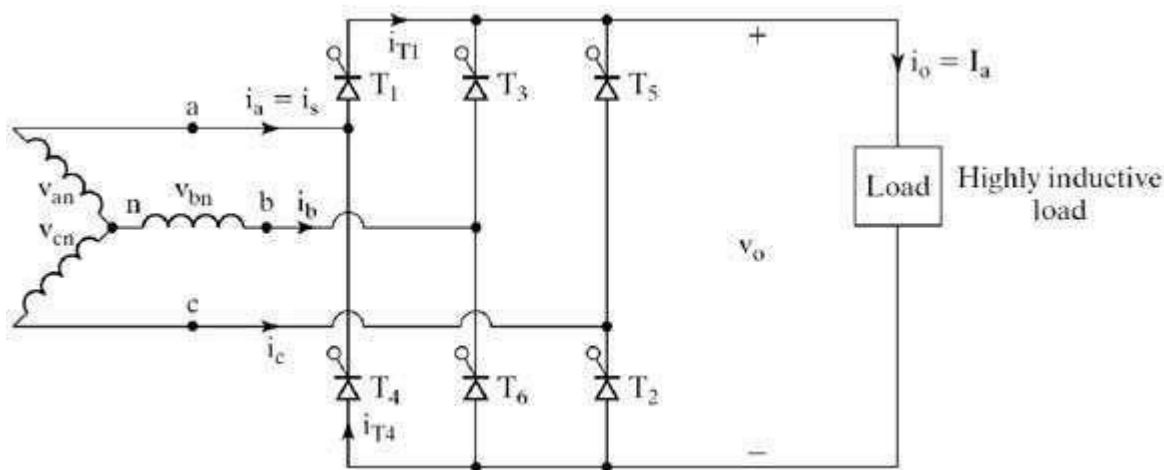

Figure: 2.20 circuit diagram three phase fully controlled rectifier with R and RL load

At $\omega t = (\pi/6 + \alpha)$, thyristor is already conducting when the thyristor is turned on by applying the gating signal to the gate of . During the time period $\omega t = (\pi/6 + \alpha)$ to $(\pi/2 + \alpha)$, thyristors and conduct together and the line to line supply voltage appears across the load.

At $\omega t = (\pi/2 + \alpha)$, the thyristor T_2 is triggered and T_6 is reverse biased immediately and T_6 turns off due to natural commutation. During the time period $\omega t = (\pi/6 + \alpha)$ to $(5\pi/6 + \alpha)$, thyristor T_1 and T_2 conduct together and the line to line supply voltage appears across the load.

The thyristors are numbered in the circuit diagram corresponding to the order in which they are triggered. The trigger sequence (firing sequence) of the thyristors is 12, 23, 34, 45, 56, 61, 12, 23, and so on. The figure shows the waveforms of three phase input supply voltages, output voltage, the thyristor current through T_1 and T_4 , the supply current through the line 'a'.

We define three line neutral voltages (3 phase voltages) as follows

$$V_{RN} = V_{an} = V_m \sin \omega t \text{ where } V_m \text{ is the maximum voltage}$$

$$V_{YN} = V_{bn} = V_m \sin \left(\omega t - \frac{2\pi}{3} \right)$$

$$V_{BN} = V_{cn} = V_m \sin \left(\omega t - \frac{4\pi}{3} \right)$$

The corresponding line to line voltages are

$$V_{RY} = V_{ab} = V_{an} - V_{bn} = \sqrt{3} V_m \sin \left(\omega t + \frac{\pi}{6} \right)$$

$$V_{YB} = V_{bc} = V_{bn} - V_{cn} = \sqrt{3} V_m \sin \left(\omega t - \frac{\pi}{2} \right)$$

$$V_{BR} = V_{ca} = V_{cn} - V_{an} = \sqrt{3} V_m \sin \left(\omega t + \frac{\pi}{2} \right)$$

To derive an expression for the average output voltage of **three phase full converter** with highly inductive load assuming continuous and constant load current

The output load voltage consists of 6 voltage pulses over a period of 2π radians, hence the average output voltage is calculated as

$$\begin{aligned} V_{avg} &= \frac{6}{2\pi} \int_{\frac{\pi}{6} + \alpha}^{\frac{\pi}{2} + \alpha} V_o d(\omega t) \\ V_o &= V_{ab} = \sqrt{3} V_m \sin \left(\omega t + \frac{\pi}{6} \right) \\ V_{avg} &= \frac{3}{\pi} \int_{\frac{\pi}{6} + \alpha}^{\frac{\pi}{2} + \alpha} \sqrt{3} V_m \sin \left(\omega t + \frac{\pi}{6} \right) d(\omega t) \\ &= \frac{3\sqrt{3}V_m}{\pi} \cos \alpha \\ &= \frac{3V_m L}{\pi} \cos \alpha \end{aligned}$$

The RMS value of the output voltage is found from

$$\begin{aligned}
 V_{\text{orms}} &= \left[\frac{6}{2\pi} \int_{\frac{\pi}{6}+\alpha}^{\frac{\pi}{2}+\alpha} V_0^2 d(\omega t) \right]^{1/2} \\
 &= \left[\frac{6}{2\pi} \int_{\frac{\pi}{6}+\alpha}^{\frac{\pi}{2}+\alpha} V_{ab}^2 d(\omega t) \right]^{1/2} \\
 &= \left[\frac{6}{2\pi} \int_{\frac{\pi}{6}+\alpha}^{\frac{\pi}{2}+\alpha} 3 V_m^2 \sin^2 \left(\omega t + \frac{\pi}{6} \right) d(\omega t) \right]^{1/2} \\
 &= \sqrt{3} V_m \left(\frac{1 + \frac{3\sqrt{3}}{4\pi} \cos 2\alpha}{2} \right)^{1/2}
 \end{aligned}$$

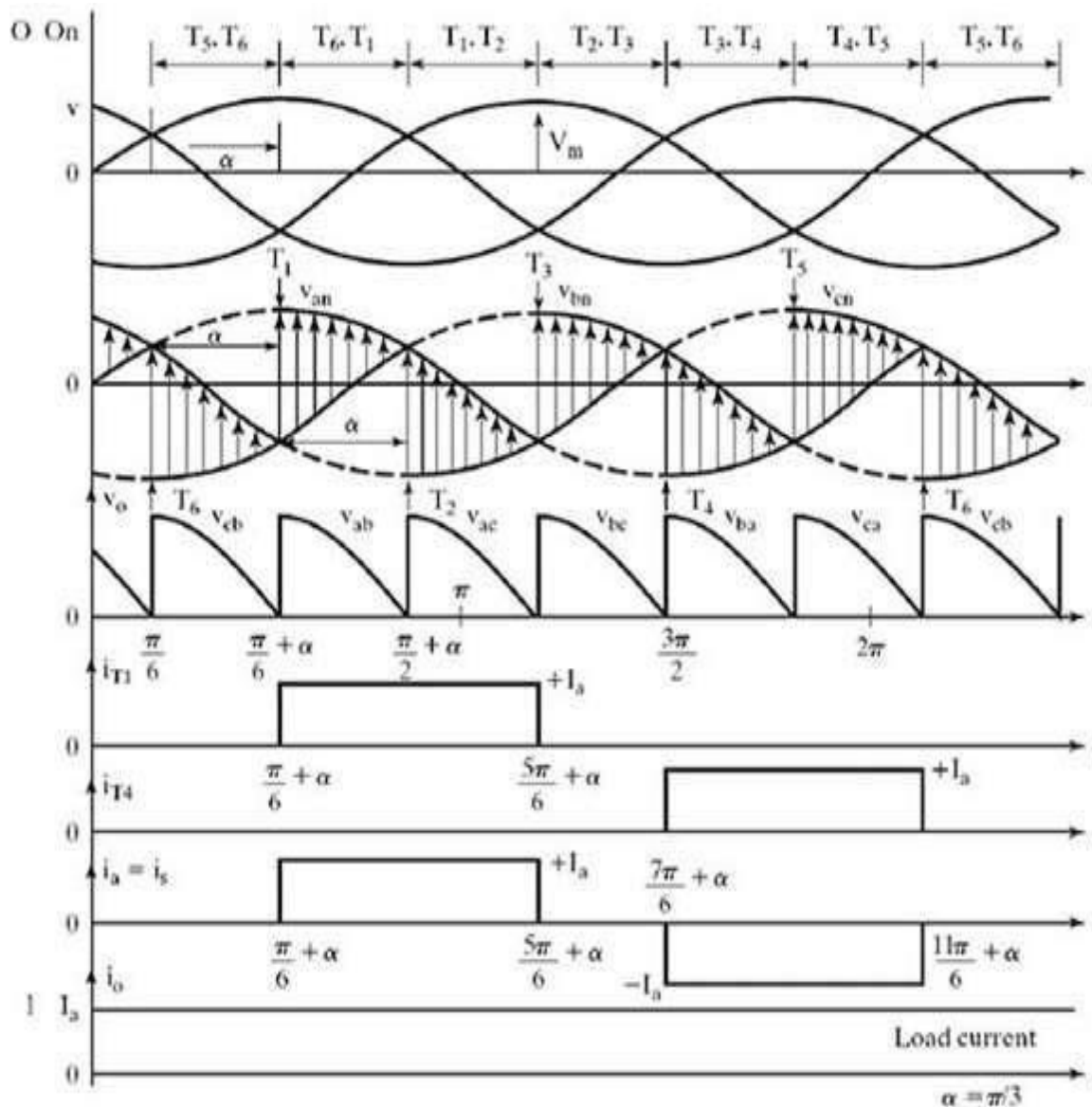

Figure: 2.21 Input and output waveforms of three phase fully controlled rectifier

Operation of three phase half wave rectifier with RLE loads

A three phase fully controlled converter is obtained by replacing all the six diodes of an uncontrolled converter by six thyristors as shown in Figure

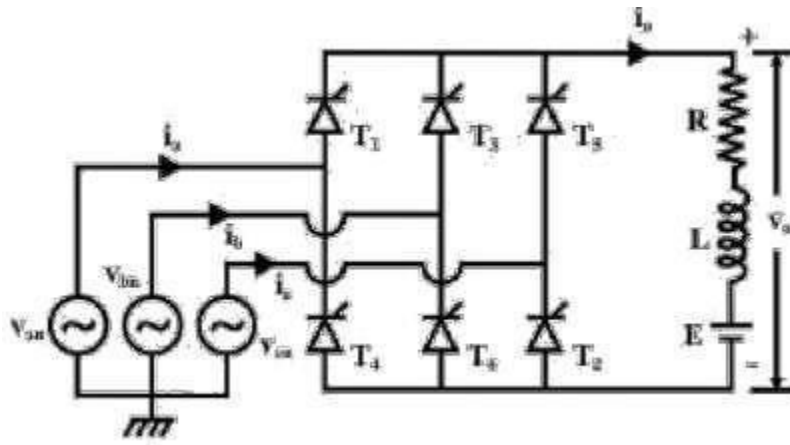

Figure: 2.22 circuit diagram of three phase fully controlled rectifier with RLE load

For any current to flow in the load at least one device from the top group (T1, T3, T5) and one from the bottom group (T2, T4, T6) must conduct. It can be argued as in the case of an uncontrolled converter only one device from these two groups will conduct.

Then from symmetry consideration it can be argued that each thyristor conducts for 120° of the input cycle. Now the thyristors are fired in the sequence $T1 \rightarrow T2 \rightarrow T3 \rightarrow T4 \rightarrow T5 \rightarrow T6 \rightarrow T1$ with 60° interval between each firing. Therefore thyristors on the same phase leg are fired at an interval of 180° and hence can not conduct simultaneously. This leaves only six possible conduction mode for the converter in the continuous conduction mode of operation. These are T1T2, T2T3, T3T4, T4T5, T5T6, T6T1. Each conduction mode is of 60° duration and appears in the sequence mentioned. Each of these line voltages can be associated with the firing of a thyristor with the help of the conduction table-1. For example the thyristor T1 is fired at the end

of T5 T6 conduction interval. During this period the voltage across T1 was v_{ac} . Therefore T1 is fired α angle after the positive going zero crossing of v_{ac} . similar observation can be made about other thyristors.

Fig. 2.23 shows the waveforms of different variables. To arrive at the waveforms it is necessary to draw the conduction diagram which shows the interval of conduction for each thyristor and can be drawn with the help of the phasor diagram of fig. 2.22. If the converter firing angle is α each thyristor is fired " α "

angle after the positive going zero crossing of the line voltage with which it's firing is associated. Once the conduction diagram is drawn all other voltage waveforms can be drawn from the line voltage waveforms and from the conduction table of fig. 2.22. Similarly line currents can be drawn from the output current and the conduction diagram. It is clear from the waveforms that output voltage and current waveforms are periodic over one sixth of the input cycle. Therefore this converter is also called

the “six pulse” converter. The input current on the other hand contains only odds harmonics of the input frequency other than the triplex (3rd, 9th etc.) harmonics. The next section will analyze the operation of this converter in more details.

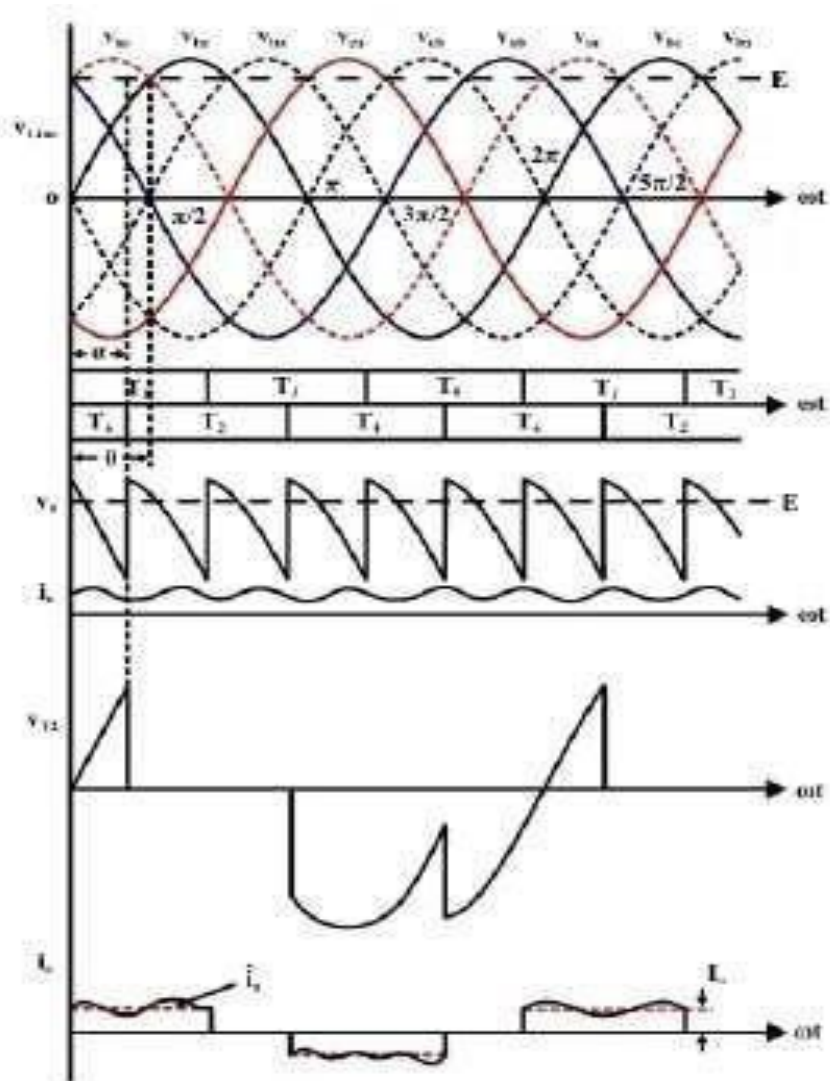

Figure: 2.23 Input and output waveforms of three phase fully controlled rectifier in rectifier mode

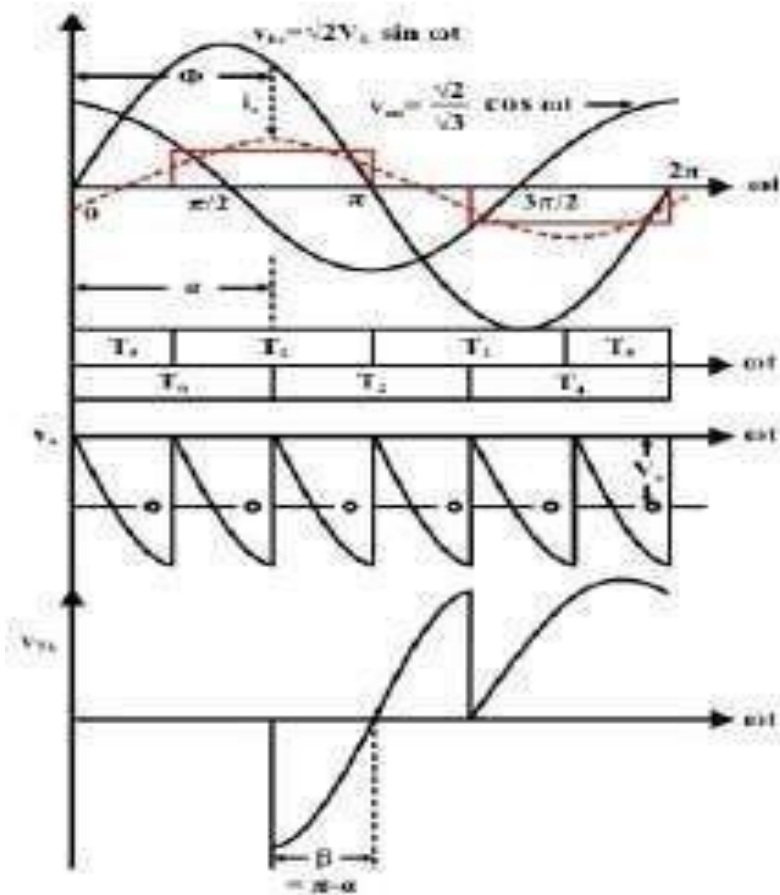

Figure: 2.24 Input and output waveforms of three phase fully controlled rectifier in inversion mode

Effect of source inductance in three phase rectifiers

The three phase fully controlled converter was analyzed with ideal source with no internal impedance. When the source inductance is taken into account, the qualitative effects on the performance of the converter is similar to that in the case of a single phase converter. Fig. 2.25 shows such a converter. As in the case of a single phase converter the load is assumed to be highly inductive such that the load can be replaced by a current source.

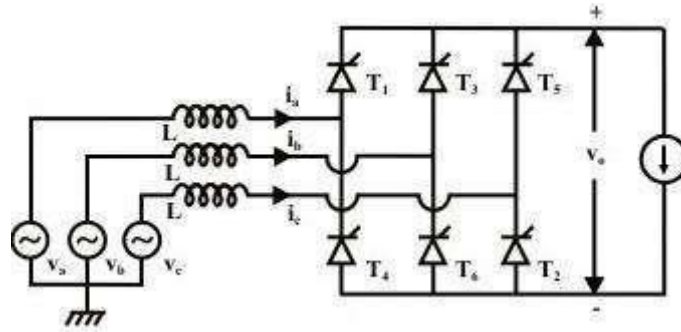

Figure: 2.25 circuit diagram for three phase rectifier with source inductance

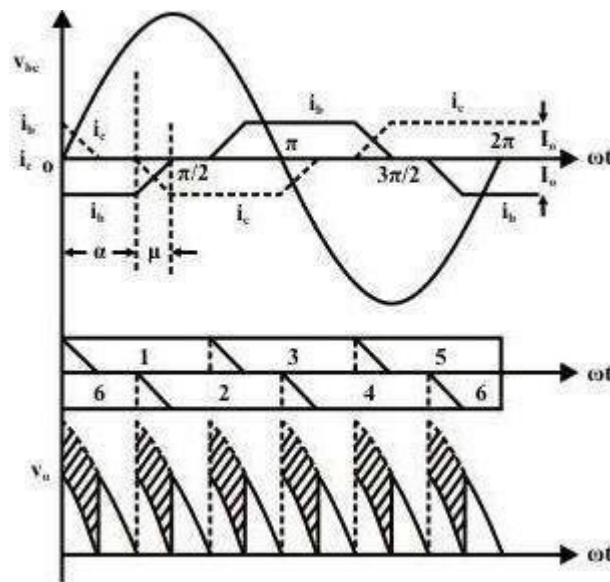

Figure: 2.26 waveforms for three phase rectifier with source inductance

As in the case of a single phase converter, commutations are not instantaneous due to the presence of source inductances. It takes place over an overlap period of “ μ_1 ” instead. During the overlap period three thyristors instead of two conducts. Current in the outgoing thyristor gradually decreases to zero while the incoming thyristor current increases and equals the total load current at the end of the overlap period. If the duration of the overlap period is greater than 60° four thyristors may also conduct clamping the output voltage to zero for some time. However, this situation is not very common and will not be discussed any further in this lesson. Due to the conduction of two devices during commutation either from the top group or the bottom group the instantaneous output voltage during the overlap period drops (shown by the

hatched portion of Fig. 2.26 resulting in reduced average voltage. The exact amount of this reduction can be calculated as follows.

In the time interval $\alpha < \omega t \leq \alpha + \mu$, T_6 and T_2 from the bottom group and T_1 from the top group conducts.

The equivalent circuit of the converter during this period is given by the circuit diagram of Fig. 2.27

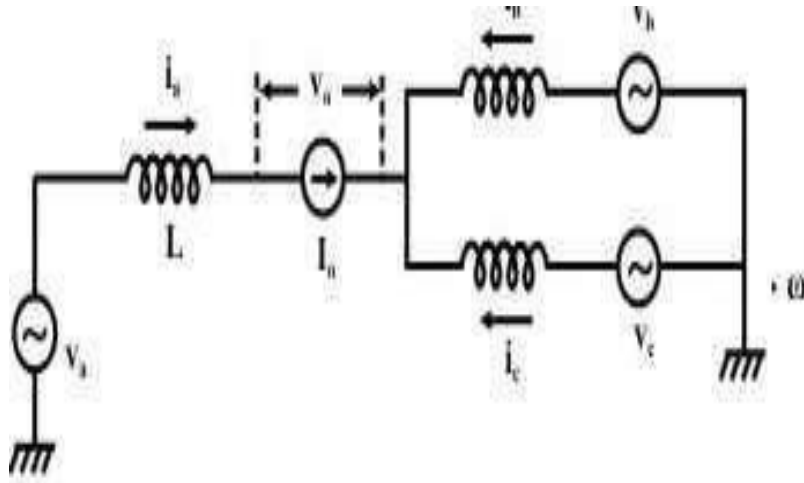

Figure: 2.27 Equivalent circuit of waveforms with source inductance

Therefore, in the interval $\alpha < \omega t \leq \alpha + \mu$

$$v_b = L \frac{di_b}{dt} - L \frac{di_c}{dt} + v_c$$

or,
$$v_{bc} = L \frac{d}{dt}(i_b - i_c)$$

but $i_b + i_c + I_0 = 0 \quad \therefore \frac{di_b}{dt} = -\frac{di_c}{dt}$

$\therefore 2L \frac{d}{dt} i_b = v_{bc} = \sqrt{2} V_L \sin \omega t$

$\therefore i_b = C - \frac{\sqrt{2} V_L}{2\omega L} \cos \omega t$

at $\omega t = \alpha, \quad i_b = -I_0 \quad \therefore C = \frac{\sqrt{2} V_L}{2\omega L} \cos \alpha - I_0$

$\therefore i_b = \frac{\sqrt{2} V_L}{2\omega L} (\cos \alpha - \cos \omega t) - I_0$

at $\omega t = \alpha + \mu, \quad i_b = 0$

$\therefore \frac{\sqrt{2} V_L}{2\omega L} (\cos \alpha - \cos(\alpha + \mu)) = I_0$

Or, $\cos \alpha - \cos(\alpha + \mu) = \frac{\sqrt{2} \omega L}{V_L} I_0$

for $\mu \leq 60^\circ$. It can be shown that for this condition to be satisfied

$$I_0 \leq \frac{V_L}{\sqrt{2}\omega L} \cos\left(\alpha - \frac{\pi}{3}\right)$$

To calculate the dc voltage

For $\alpha \leq \omega t \leq \alpha + \mu$

$$v_0 = v_a - v_b + L \frac{di_b}{dt} = \frac{3}{2} v_a$$

for $\alpha + \mu \leq \omega t \leq \alpha + \frac{\pi}{3}$ $v_0 = V_{ac}$

$$\therefore V_0 = \frac{3}{\pi} \left[\int_{\alpha}^{\alpha+\mu} \frac{3}{2} v_a d\omega t + \int_{\alpha+\mu}^{\alpha+\frac{\pi}{3}} v_{ac} d\omega t \right]$$

$$= \frac{3}{\pi} \left[\int_{\alpha}^{\alpha+\mu} \left(v_{ac} + \frac{3}{2} v_a - v_{ac} \right) + \int_{\alpha+\mu}^{\alpha+\frac{\pi}{3}} v_{ac} d\omega t \right]$$

$$= \frac{3}{\pi} \left[\int_{\alpha}^{\alpha+\frac{\pi}{3}} v_{ac} d\omega t + \int_{\alpha}^{\alpha+\mu} \left(\frac{v_a}{2} + v_0 \right) d\omega t \right]$$

$$= \frac{3\sqrt{2}}{\pi} V_L \cos\alpha - \frac{3}{2\pi} \int_{\alpha}^{\alpha+\mu} v_{ac} d\omega t$$

or
$$V_0 = \frac{3\sqrt{2}}{\pi} V_L \cos\alpha - \frac{3\sqrt{2}V_L}{2\pi} \int_{\alpha}^{\alpha+\mu} \sin\omega t d\omega t$$

$$= \frac{3\sqrt{2}}{\pi} V_L \cos\alpha - \frac{3\sqrt{2}V_L}{2\pi} [\cos\alpha - \cos(\alpha + \mu)]$$

$$V_0 = \frac{3\sqrt{2}}{\pi} V_L \cos\alpha - \frac{3}{\pi} \omega L I_0$$

Introduction to dual converters

Dual converter, the name itself says two converters. It is really an electronic converter or circuit which comprises of two converters. One will perform as rectifier and the other will perform as inverter. Therefore, we can say that double processes will occur at a moment. Here, two full converters are arranged in anti-parallel pattern and linked to the same dc load. These converters can provide four quadrant operations. The basic block diagram is shown below

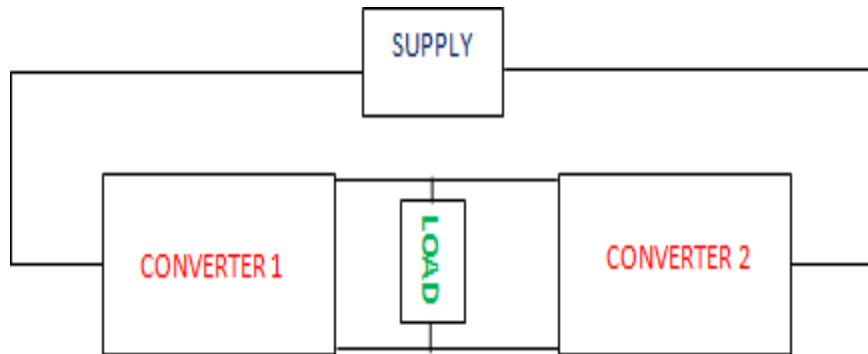

Figure: 2.28 Block diagram of dual converter

Modes of Operation of Dual Converter

There are two functional modes: Non-circulating current mode and circulating mode.

Non Circulating Current Mode

- One converter will perform at a time. So there is no circulating current between the converters.
- During the converter 1 operation, firing angle (α_1) will be $0 < \alpha_1 < 90^\circ$; V_{dc} and I_{dc} are positive.
- During the converter 2 operation, firing angle (α_2) will be $0 < \alpha_2 < 90^\circ$; V_{dc} and I_{dc} are negative.

Circulating Current Mode

- Two converters will be in the ON condition at the same time. So circulating current is present.
- The firing angles are adjusted such that firing angle of converter 1 (α_1) + firing angle of converter 2 (α_2) = 180° .
- Converter 1 performs as a controlled rectifier when firing angle be $0 < \alpha_1 < 90^\circ$ and Converter 2 performs as an inverter when the firing angle be $90^\circ < \alpha_2 < 180^\circ$. In this condition, V_{dc} and I_{dc} are positive.
 - Converter 1 performs as an inverter when firing angle be $90^\circ < \alpha_1 < 180^\circ$ and Converter 2 performs as a controlled rectifier when the firing angle be $0 < \alpha_2 < 90^\circ$. In this condition, V_{dc} and I_{dc} are negative.
- The four quadrant operation is shown below

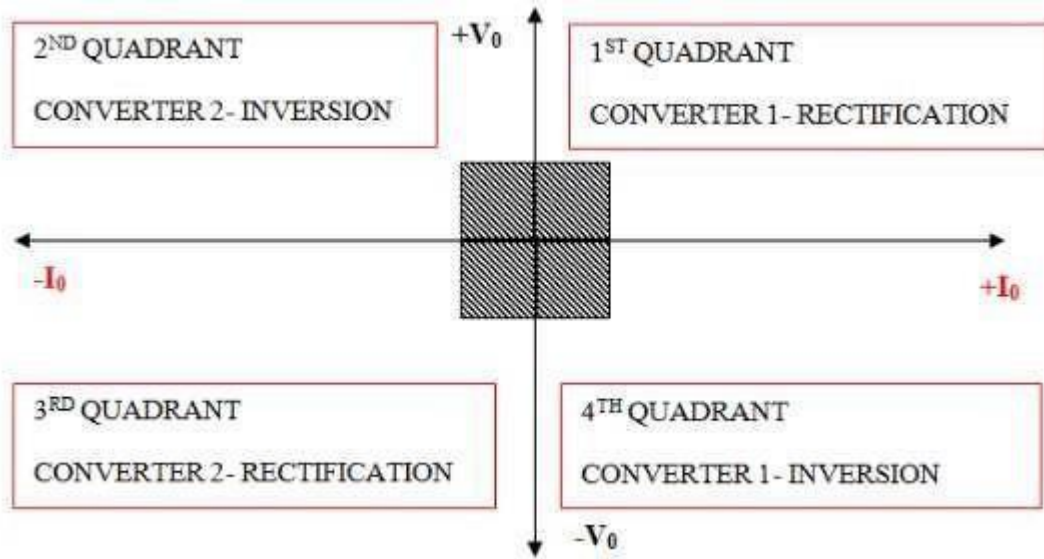

Figure: 2.29 Four quadrant operations of dual converter

Ideal Dual Converter

The term 'ideal' refers to the ripple free output voltage. For the purpose of unidirectional flow of DC current, two diodes (D_1 and D_2) are incorporated between the converters. However, the direction of current can be in any way. The average output voltage of the converter 1 is V_{o1} and converter 2 is V_{o2} . To make the output voltage of the two converters in same polarity and magnitude, the firing angles of the Thyristors have to be controlled.

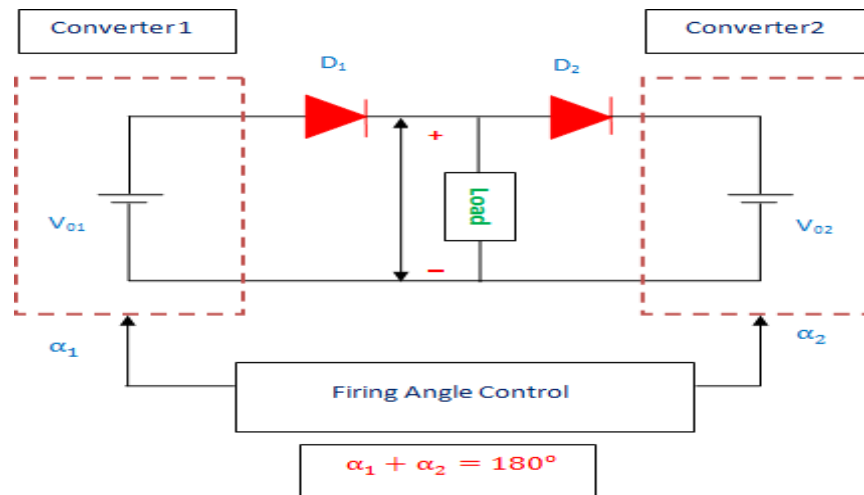

Figure: 2.30 Ideal dual converter

Single Phase Dual Converter

The source of this type of converter will be single-phase supply. Consider, the converter is in non-circulating mode of operation. The input is given to the converter 1 which converts the AC to DC by the method of rectification. It is then given to the load after filtering. Then, this DC is provided to the converter 2 as input. This converter performs as inverter and converts this DC to AC. Thus, we get AC as output. The circuit diagram is shown below.

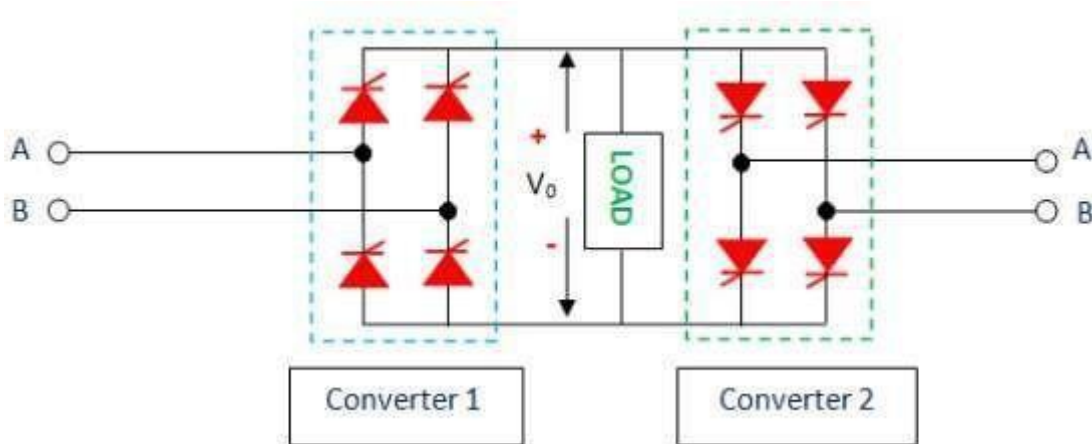

Figure: 2.31 Single phase Dual converter

$$\text{Average output voltage of Single-phase converter} = \frac{2V_m \cos \alpha}{\pi}$$

$$\text{Average output voltage of Three-phase converter} = \frac{3V_{ml} \cos \alpha}{\pi}$$

$$\text{For converter 1, the average output voltage, } V_{01} = V_{max} \cos \alpha_1$$

$$\text{For converter 2, the average output voltage, } V_{02} = V_{max} \cos \alpha_2$$

$$V_0 = V_{01} = -V_{02}$$

$$V_{max} \cos \alpha_1 = -V_{max} \cos \alpha_2$$

$$\cos \alpha_1 = \cos(180^\circ - \alpha_2) \text{ or } \cos \alpha_2 = \cos(180^\circ + \alpha_2)$$

$$\text{Output voltage, } \alpha_1 + \alpha_2 = 180^\circ \text{ And } \alpha_1 - \alpha_2 = 180^\circ$$

The firing angle can never be greater than 180° . So, $\alpha_1 + \alpha_2 = 180^\circ$

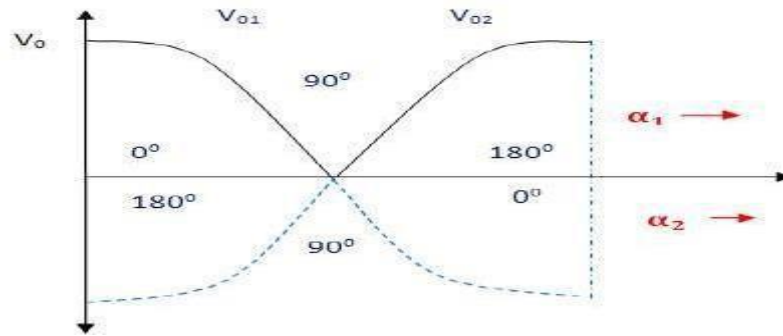

Figure: 2.32 output voltage variation with firing angle

Three Phase Dual Converter

Here, three-phase rectifier and three-phase inverter are used. The processes are similar to single-phase dual converter. The three-phase rectifier will do the conversion of the three-phase AC supply to the DC. This DC is filtered and given to the input of the second converter. It will do the DC to AC conversion and the output that we get is the three-phase AC. Applications where the output is up to 2 megawatts. The circuit is shown below.

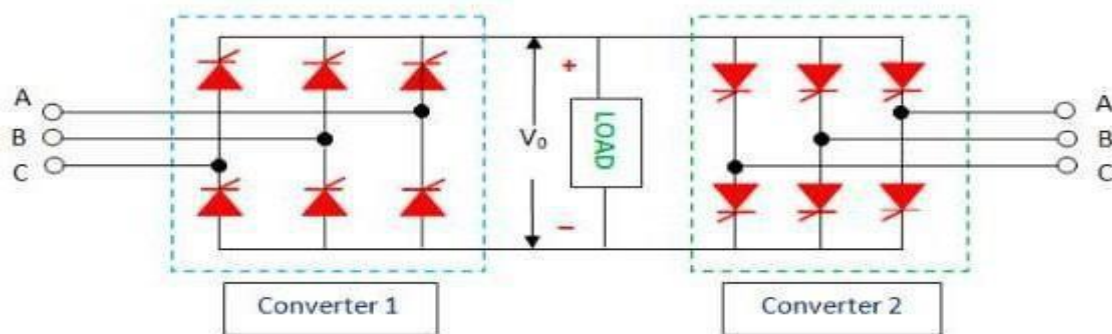

Figure: 2.33 Three phase dual converter

Application of Dual Converter

- Direction and Speed control of DC motors.
- Applicable wherever the reversible DC is required.
- Industrial variable speed DC drives.

UNIT – III

AC voltage controllers and Cycloconverters

Introduction to AC voltage controllers

AC voltage controllers (ac line voltage controllers) are employed to vary the RMS value of the alternating voltage applied to a load circuit by introducing Thyristors between the load and a constant voltage ac source. The RMS value of alternating voltage applied to a load circuit is controlled by controlling the triggering angle of the Thyristors in the **AC Voltage Controller circuits**.

In brief, an **AC Voltage Controller** is a type of thyristor power converter which is used to convert a fixed voltage, fixed frequency ac input supply to obtain a variable voltage ac output. The RMS value of the ac output voltage and the ac power flow to the load is controlled by varying (adjusting) the trigger angle ' α '

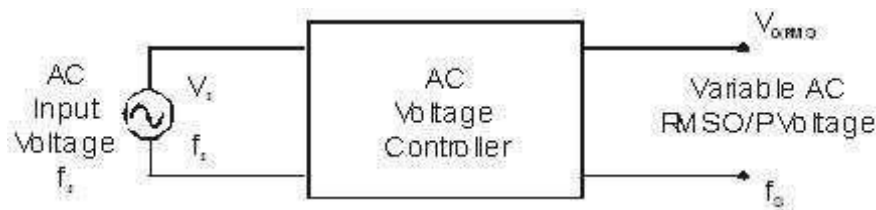

Figure: 3.1 Block diagram of AC voltage controller

Control strategies: There are two different types of thyristor control used in practice to control the ac power flow

1. On-Off control
2. Phase control

These are the two ac output voltage control techniques. In On-Off control technique Thyristors are used as switches to connect the load circuit to the ac supply (source) for a few cycles of the input ac supply and then to disconnect it for few input cycles. The Thyristors thus act as a high speed contactor (or high speed ac switch).

Phase control

In phase control the Thyristors are used as switches to connect the load circuit to the input ac supply, for a part of every input cycle. That is the ac supply voltage is chopped using Thyristors during a part of each input cycle.

The thyristor switch is turned on for a part of every half cycle, so that input supply voltage appears across the load and then turned off during the remaining part of input half cycle to disconnect the ac supply from the load.

By controlling the phase angle or the trigger angle ' α ' (delay angle), the output RMS voltage across the load can be controlled.

The trigger delay angle ' α ' is defined as the phase angle (the value of ωt) at which the thyristor turns on and the load current begins to flow.

Thyristor **AC Voltage Controllers** use ac line commutation or ac phase commutation. Thyristors in **AC Voltage Controllers** are line commutated (phase commutated) since the input supply is ac. When the input ac voltage reverses and becomes negative during the negative half cycle the current flowing through the conducting thyristor decreases and falls to zero. Thus the ON thyristor naturally turns off, when the device current falls to zero.

Phase control Thyristors which are relatively inexpensive, converter grade Thyristors which are slower than fast switching inverter grade Thyristors are normally used.

For applications upto 400Hz, if Triacs are available to meet the voltage and current ratings of a particular application, Triacs are more commonly used.

Due to ac line commutation or natural commutation, there is no need of extra commutation circuitry or components and the circuits for **AC Voltage Controllers** are very simple.

Due to the nature of the output waveforms, the analysis, derivations of expressions for performance parameters are not simple, especially for the phase controlled **AC Voltage Controllers** with RL load. But however most of the practical loads are of the RL type and hence RL load should be considered in the analysis and design of **AC Voltage Controllers** circuits.

Type of ac voltage controllers

The ac voltage controllers are classified into two types based on the type of input ac supply applied to the circuit.

- **Single Phase AC Controllers**
- **Three Phase AC Controllers**

Single Phase AC Controllers operate with single phase ac supply voltage of 230V RMS at 50Hz in our country. **Three Phase AC Controllers** operate with 3 phase ac supply of 400V RMS at 50Hz supply frequency.

Performance parameters of ac voltage controllers

- RMS Output (Load) Voltage

$$V_{O(RMS)} = \left[\frac{n}{2\pi(n+m)} \int_0^{2\pi} V_m^2 \sin^2 \omega t \cdot d(\omega t) \right]^{1/2}$$

$$V_{O(RMS)} = \frac{V_m}{\sqrt{2}} \sqrt{\frac{n}{m+n}} = V_{i(RMS)} \sqrt{k} = V_s \sqrt{k}$$

$$V_{O(RMS)} = V_{i(RMS)} \sqrt{k} = V_s \sqrt{k}$$

Where $V_s = V_{i(RMS)}$ = RMS value of input supply voltage.

- Duty Cycle

$$k = \frac{t_{ON}}{T_O} = \frac{t_{ON}}{(t_{ON} + t_{OFF})} = \frac{nT}{(m+n)T}$$

Where, $k = \frac{n}{m+n}$ = duty cycle (d).

- RMS Load Current

$$I_{O(RMS)} = \frac{V_{O(RMS)}}{Z} = \frac{V_{O(RMS)}}{R_L}; \quad \text{for a resistive load } Z = R_L.$$

- Output AC (Load) Power

$$P_O = I_{\alpha(RMS)}^2 \times R_L$$

- Input Power Factor

$$PF = \frac{P_O}{VA} = \frac{\text{output load power}}{\text{input supply volt amperes}} = \frac{P_O}{V_S I_S}$$

$$PF = \frac{I_{\alpha(RMS)}^2 \times R_L}{V_{i(RMS)} \times I_{m(RMS)}}; \quad I_S = I_{m(RMS)} = \text{RMS input supply current}$$

The input supply current is same as the load current $I_m = I_O = I_L$

Hence, RMS supply current = RMS load current; $I_{m(RMS)} = I_{\alpha(RMS)}$

$$PF = \frac{I_{\alpha(RMS)}^2 \times R_L}{V_{i(RMS)} \times I_{m(RMS)}} = \frac{V_{\alpha(RMS)}}{V_{i(RMS)}} = \frac{V_{i(RMS)} \sqrt{k}}{V_{i(RMS)}} = \sqrt{k}$$

$$PF = \sqrt{k} = \sqrt{\frac{n}{m+n}}$$

Applications of ac voltage controllers

- Lighting / Illumination control in ac power circuits.
- Induction heating.
- Industrial heating & Domestic heating.
- Transformers tap changing (on load transformer tap changing).
- Speed control of induction motors (single phase and poly phase ac induction motor control).
- AC magnet controls.

Single phase AC voltage controller with R load

AC to AC voltage converters operate on the AC mains essentially to regulate the output voltage. Portions of the supply sinusoid appear at the load while the semiconductor switches block the remaining portions. Several topologies have emerged along with voltage regulation methods, most of which are linked to the development of the semiconductor devices.

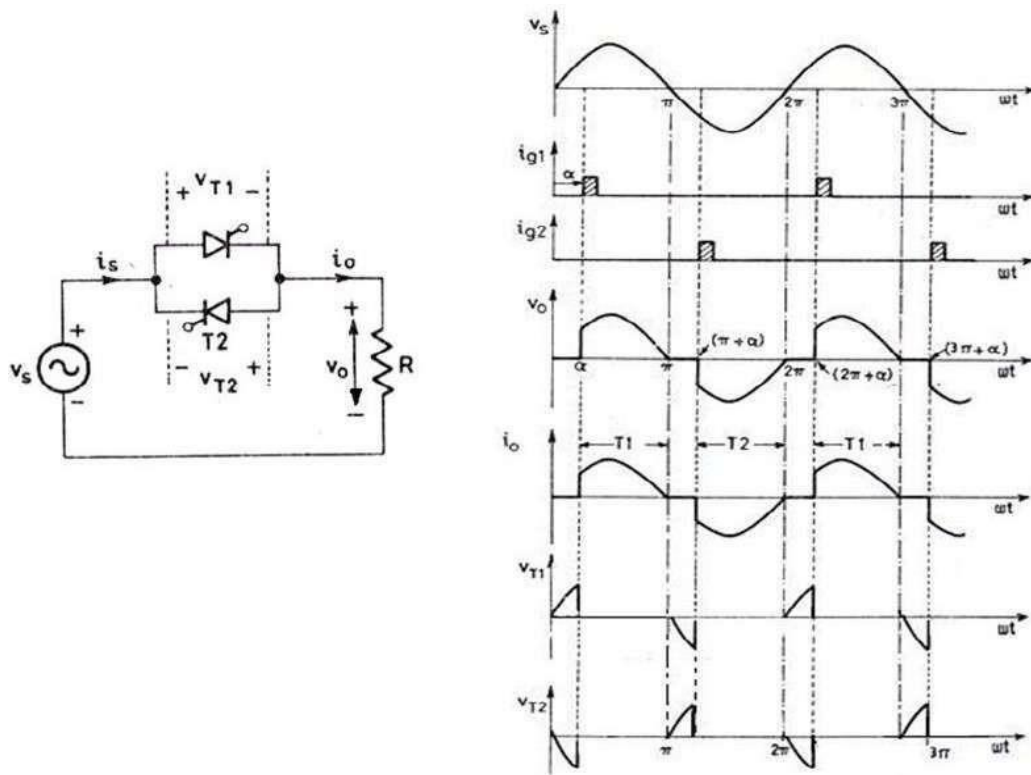

Figure: 3.2 Circuit diagram and output waveforms of AC voltage controller with R load

Fig. 2.35 illustrates the operation of the PAC converter with a resistive load. The device(s) is triggered at a phase-angle ' α ' in each cycle. The current follows the voltage wave shape in each half and extinguishes itself at the zero crossings of the supply voltage. In the two-SCR topology, one SCR is positively biased in each half of the supply voltage. There is no scope for conduction overlap of the devices. A single pulse is sufficient to trigger the controlled devices with a resistive load. In the diode-SCR topology, two diodes are forward biased in each half. The SCR always receives a DC voltage and does not distinguish the polarity of the supply. It is thus always forward biased. The bi-directional TRIAC is also forward biased for both polarities of the supply voltage.

The rms voltage V_{rms} decides the power supplied to the load. It can be computed as

$$V_{rms} = \sqrt{\frac{1}{\pi} \int_{\alpha}^{\pi} 2V^2 \sin^2 \omega t \, d\omega t}$$

$$= V \sqrt{1 - \frac{\alpha}{\pi} + \frac{\sin 2\alpha}{2\pi}}$$

Power Factor

The power factor of a nonlinear deserves a special discussion. Fig. 2.35 shows the supply voltage and the non-sinusoidal load current. The fundamental load/supply current lags the supply voltage by the ϕ_1 , 'Fundamental Power Factor' angle. $\cos\phi_1$ is also called the 'Displacement Factor'. However this does not account for the total reactive power drawn by the system. This power factor is in spite of the actual load being resistive! The reactive power is drawn also by the trigger-angle dependent harmonics. Now

$$\text{power factor} = \frac{\text{average power}}{\text{apparent voltamperes}} = \frac{P}{VI_L}$$

$$= \frac{VI_{L1} \cos \phi_1}{VI_L}$$

$$\text{distortion factor} = \frac{I_{L1}}{I_L}$$

The Average Power, P drawn by the resistive load is

$$P = \frac{1}{2\pi} \int_0^{2\pi} v i_L \, d\omega t = \frac{1}{\pi} \int_{\alpha}^{\pi} \frac{2V^2}{R} \sin^2 \omega t \, d\omega t$$

$$= \frac{2V^2}{R\pi} \left[\pi - \frac{\alpha}{2} + \frac{\sin 2\alpha}{2} \right]$$

Single phase AC voltage controller with RL load

With inductive loads the operation of the PAC is illustrated in Fig 2. 36. The current builds up from zero in each cycle. It quenches not at the zero crossing of the applied voltage as with the resistive load but after that instant. The supply voltage thus continues to be impressed on the load till the load current returns to zero. A single-pulse trigger for the TRIAC) or the anti parallel SCR has no effect on the devices if it (or the anti-parallel device) is already in conduction in the reverse direction. The devices would fail to conduct when they are intended to, as they do not have the supply voltage forward biasing them when the trigger pulse arrives. A single pulse trigger will work till the trigger angle $\alpha > \phi$, where ϕ is the power factor angle of the inductive load. A train of pulses is required here. The output voltage is controllable only between triggering angles ϕ and 180° . The load current waveform is further explained in Fig. 26.6. The current is composed of two components. The first is the steady state component of the load current, i_{ss} and the second, i_{tr} is the transient component.

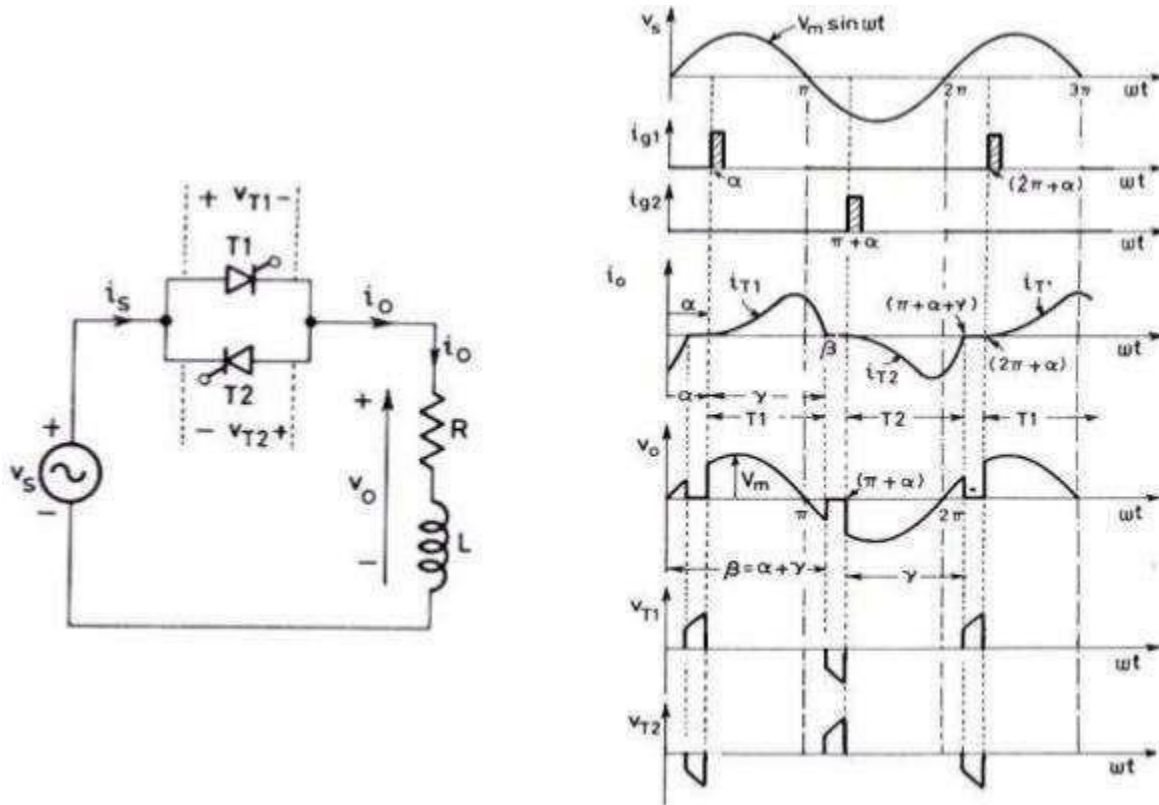

Figure: 3.3 Circuit diagram and output waveforms of AC voltage controller with RL load

With an inductance in the load the distinguishing feature of the load current is that it must always start from zero. However, if the switch could have permanently kept the load connected to the supply the current would have become a sinusoidal one phase shifted from the voltage by the phase angle of the load, ϕ . This current restricted to the half periods of conduction is called the 'steady-state component' of load current i_{ss} . The 'transient component' of load current i_{tr} , again in each half cycle, must add up to zero with this i_{ss} to start from zero. This condition sets the initial value of the transient component to that of the steady state at the instant that the SCR/TRIAC is triggered. Fig. 2. 36 illustrates these relations. When a device is in conduction, the load current is governed by the equation

$$L \frac{di}{dt} + Ri = v_s$$

$$i_{load} = \frac{\sqrt{2}V}{Z} \left[\sin(\omega t - \phi) + \sin(\alpha - \phi) e^{-\frac{R}{L}(\frac{\omega}{\omega} - t)} \right]$$

Since at $t = 0$, $i_{load} = 0$ and supply voltage $v_s = \sqrt{2}V \sin \omega t$ the solution is of the form the instant when the load current extinguishes is called the extinction angle β . It can be inferred that there would be no

transients in the load current if the devices are triggered at the power factor angle of the load. The load current I that case is perfectly sinusoidal.

Modes of operation of TRIAC

The triac is an important member of the thyristor family of devices. It is a bidirectional device that can pass the current in both forward and reverse biased conditions and hence it is an AC control device. The triac is equivalent to two back to back SCRs connected with one gate terminal as shown in figure. The triac is an abbreviation for a TRIode AC switch. TRI means that the device consisting of three terminals and AC means that it controls the AC power or it can conduct in both directions of alternating current.

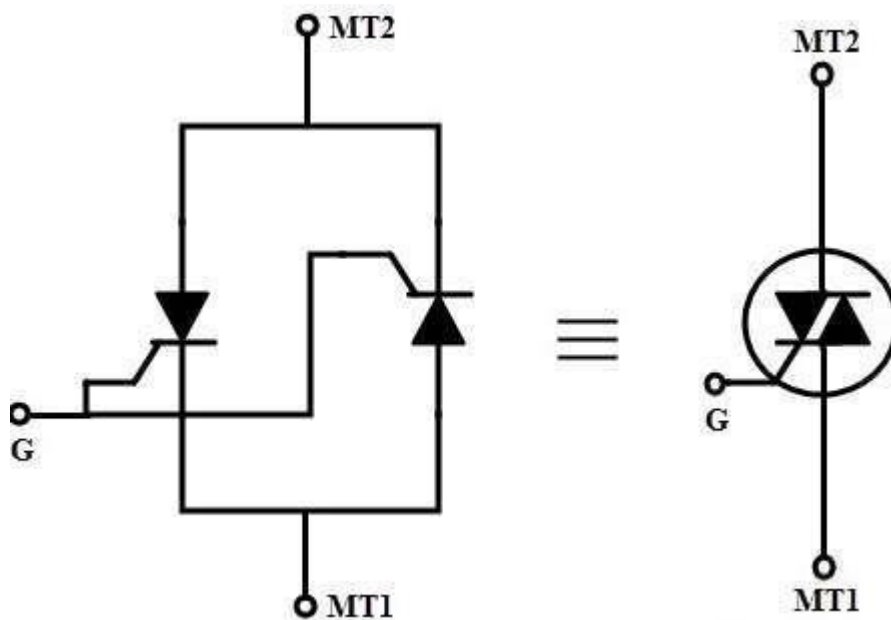

Figure: 3.4 Two thyristor analogy and circuit symbol of TRIAC

The triac has three terminals namely Main Terminal 1 (MT1), Main Terminal 2 (MT2) and Gate (G) as shown in figure. If MT1 is forward biased with respect to MT2, then the current flows from MT1 to MT2. Similarly, if the MT2 is forward biased with respect to MT1, then the current flows from MT2 to MT1. The above two conditions are achieved whenever the gate is triggered with an appropriate gate pulse. Similar to the SCR, triac is also turned by injecting appropriate current pulses into the gate terminal. Once it is turned ON, it loses its gate control over its conduction. So triac can be turned OFF by reducing the current to zero through the main terminals.

Construction of TRIAC

A triac is a five layer, three terminal semiconductor device. The terminals are marked as MT1, MT2 as anode and cathode terminals in case of SCR. And the gate is represented as G similar to the thyristor. The gate terminal is connected to both N4 and P2 regions by a metallic contact and it is near to the MT1 terminal. The terminal MT1 is connected to both N2 and P2 regions, while MT2 is connected to both N3 and P1 regions. Hence, the terminals MT1 and MT2 connected to both P and N regions of the device and thus the polarity of applied voltage between these two terminals decides the current flow through the layers of the device.

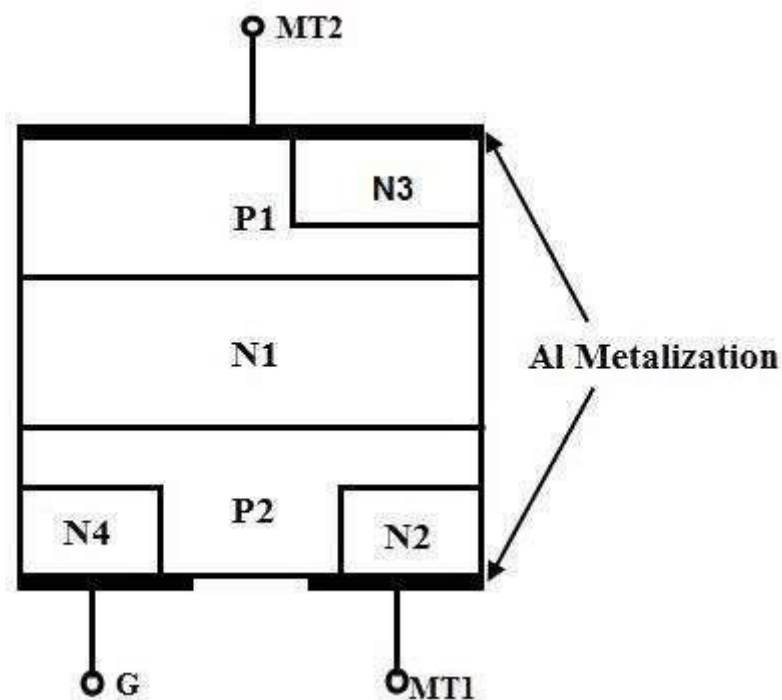

Figure: 3.5 construction of TRIAC

With the gate open, MT2 is made positive with respect to MT1 for a forward biased triac. Hence triac operates in forward blocking mode until the voltage across the triac is less than the forward break over voltage. Similarly for a reverse biased triac, MT2 is made negative with respect to MT1 with gate open. Until the voltage across the triac is less than the reverse break over voltage, device operates in a reverse blocking mode. A triac can be made conductive by either positive or negative voltage at the gate terminal.

Working and Operation of TRIAC

It is possible to connect various combinations of negative and positive voltages to the triac terminals because it is a bidirectional device. The four possible electrode potential combinations which make the triac to operate four different operating quadrants or modes are given as.

1. MT2 is positive with respect to MT1 with a gate polarity positive with respect to MT1.
2. MT2 is positive with respect to MT1 with a gate polarity negative with respect to MT1.
3. MT2 is negative with respect to MT1 with a gate polarity negative with respect to MT1.
4. MT2 is negative with respect to MT1 with a gate polarity positive with respect to MT1.

In general, latching current is higher in second quadrant or mode whilst gate trigger current is higher in the fourth mode compared with other modes for any triac. Most of the applications, negative triggering circuit is used that means 2 and 3 quadrants are used for a reliable triggering in bidirectional control and also when the gate sensitivity is critical. The gate sensitivity is highest with modes 1 and 4 are generally employed.

Mode 1: MT2 is Positive, Positive Gate Current

When the gate terminal is made positive with respect to MT1, gate current flows through the P2 and N2 junction. When this current flows, the P2 layer is flooded with electrons and further these electrons are diffused to the edge of junction J2 (or P2-N1 junction). These electrons collected by the N1 layer builds a space charge on the N1 layer. Therefore, more holes from the P1 region are diffused into the N1 region to neutralize the negative space charges. These holes arrive at the junction J2 and produce the positive space charge in the P2 region, which causes more electrons to inject into P2 from N2. This results a positive regeneration and finally the main current flows from MT2 to MT1 through the regions P1- N1 – P2 – N2.

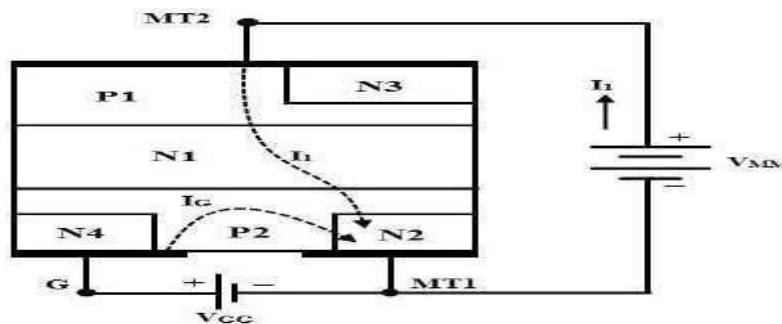

Figure: 3.6 Mode 1 operation of TRIAC

Mode 2: MT2 is Positive, Negative Gate Current

When MT2 is positive and the gate terminal is negative with respect to MT1, gate current flows through the P2-N4 junction. This gate current forward biases the P2-N4 junction for auxiliary P1N1P2N4 structure. This results the triac to conduct initially through the P1N1P2N4 layers. This further raises the potential between P2N2 towards the potential of MT2. This causes the current to establish from left to right in the P2 layer which forward biases the junction P2N2. And hence the main structure P1N1P2N2 begins to conduct. Initially conducted auxiliary structure P1N1P2N4 is considered as a pilot SCR while later conducted structure P1N1P2N2 is considered as main SCR. Hence the anode current of pilot SCR serves as gate current to the main SCR. The sensitivity to gate current is less in this mode and hence more gate current is required to turn the triac.

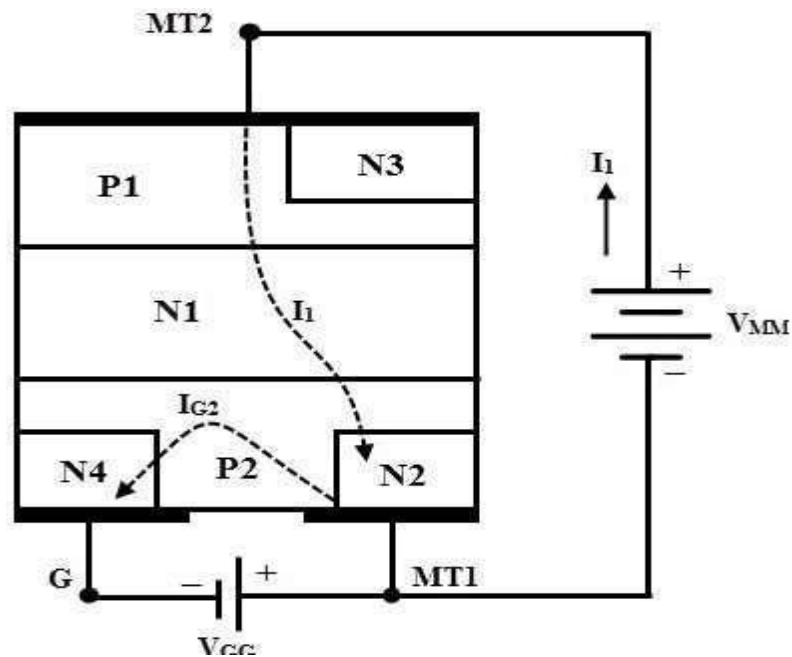

Figure: 3.7 Mode 2 operation of TRIAC

Mode 3: MT2 is Negative, Positive Gate Current

In this mode, MT2 is made negative with respect to MT1 and the device is turned ON by applying a positive voltage between the gate and MT1 terminal. The turn ON is initiated by N2 which acts as a remote gate control and the structure leads to turn ON the triac is P2N1P1N3. The external gate current forward biases the junction P2-N2. N2 layer injects the electrons into the P2 layer which are then collected by junction P2N1. This result to increases the current flow through P2N1 junction.

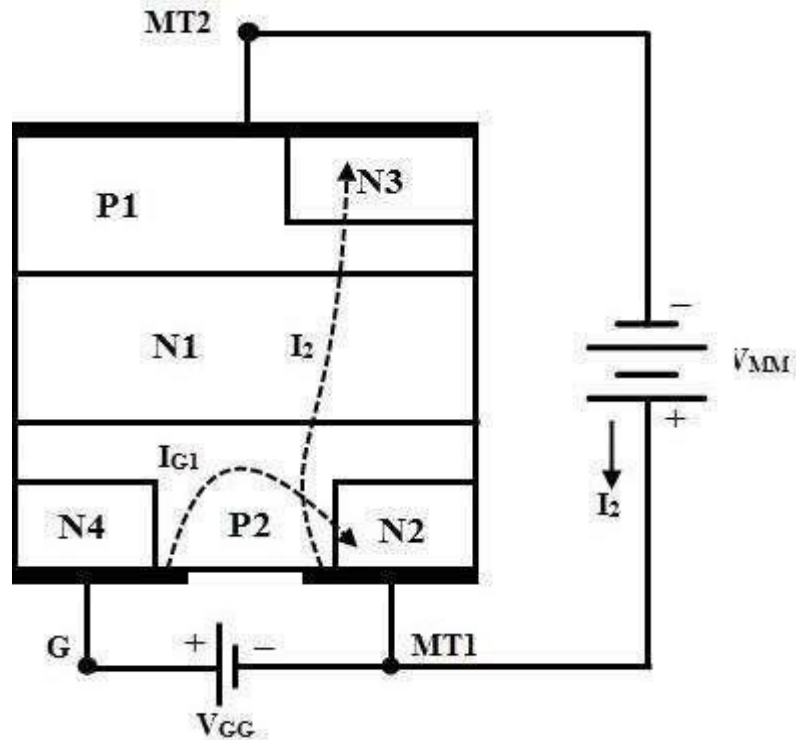

Figure: 3.8 Mode 3 operation of TRIAC

The holes injected from layer P2 diffuse through the N1 region. This builds a positive space charge in the P region. Therefore, more electrons from N3 are diffused into P1 to neutralize the positive space charges. Hence, these electrons arrive at junction J2 and produce a negative space charge in the N1 region which results to inject more holes from the P2 into the region N1. This regenerative process continues till the structure P2N1P1N3 turns ON the triac and conducts the external current. As the triac is turned ON by the remote gate N2, the device is less sensitive to the positive gate current in this mode.

Mode 4: MT2 is Negative, Negative Gate Current

In this mode N4 acts as a remote gate and injects the electrons into the P2 region. The external gate current forward biases the junction P2N4. The electrons from the N4 region are collected by the P2N1 junction increase the current across P1N1 junction. Hence the structure P2N1P1N3 turns ON by the regenerative action. The triac is more sensitive in this mode compared with positive gate current in mode 3.

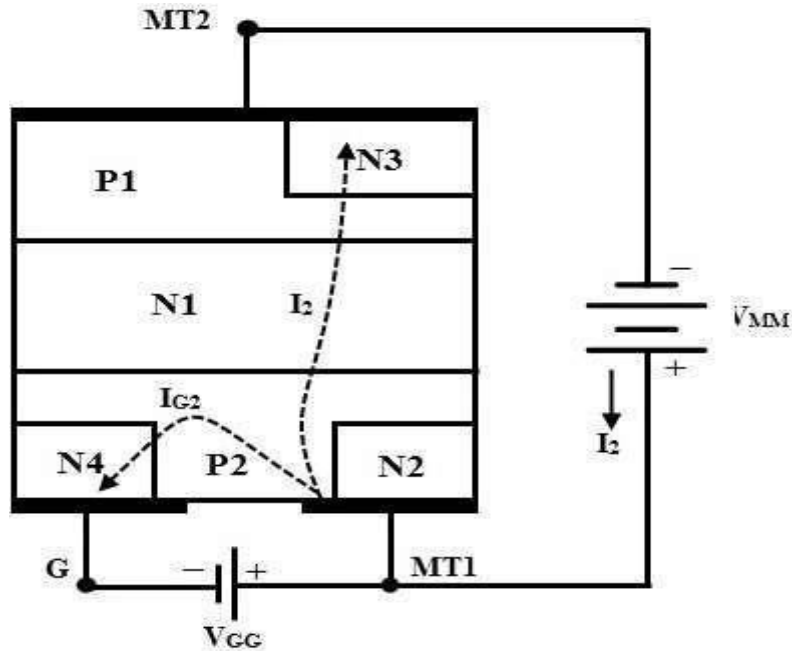

Figure: 3.9 Mode 4 operation of TRIAC

From the above discussion, it is concluded that the modes 2 and 3 are less sensitive configuration which needs more gate current to trigger the triac, whereas more common triggering modes of triac are 1 and 4 which have greater sensitivity. In practice the more sensitive mode of operation is selected such that the polarity of the gate is to match with the polarity of the terminal MT2.

Characteristics of TRIAC

The triac function like a two thyristors connected in anti-parallel and hence the VI characteristics of triac in the 1st and 3rd quadrants will be similar to the VI characteristics of a thyristors. When the terminal MT2 is positive with respect to MT1 terminal, the triac is said to be in forward blocking mode. A small leakage current flows through the device provided that voltage across the device is lower than the breakover voltage. Once the breakover voltage of the device is reached, then the triac turns ON as shown in below figure. However, it is also possible to turn ON the triac below the VBO by applying a gate pulse in such that the current through the device should be more than the latching current of the triac.

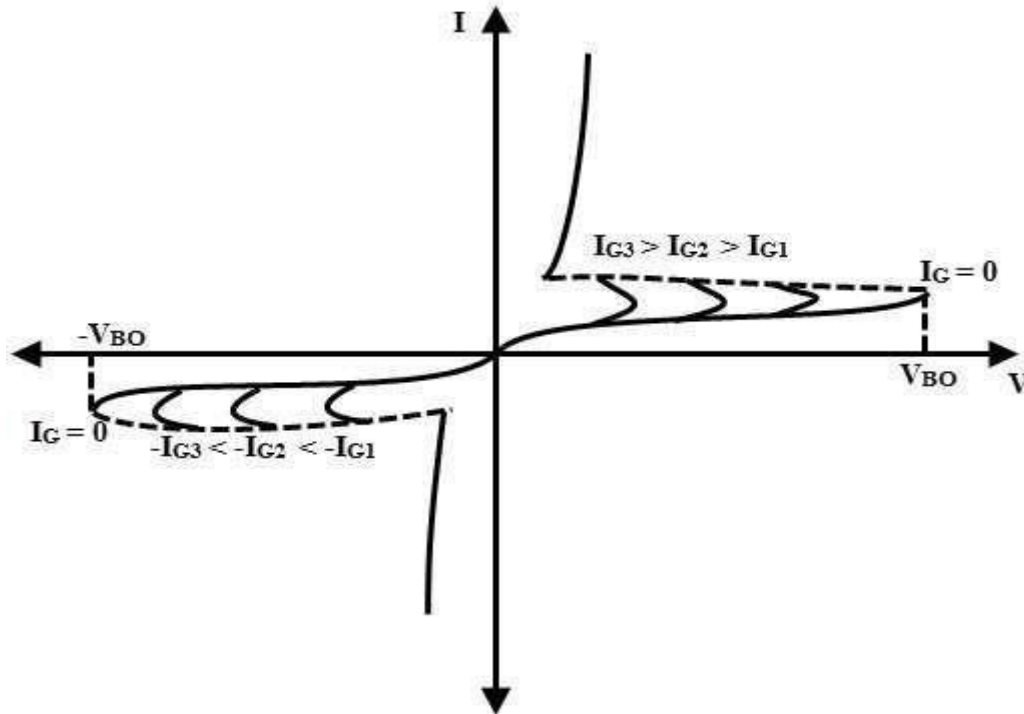

Figure: 3.10 V-I characteristics of TRIAC

Similarly, when the terminal MT2 is made negative with respect to MT1, the triac is in reverse blocking mode. A small leakage current flows through the device until it is triggered by breakover voltage or gate triggering method. Hence the positive or negative pulse to the gate triggers the triac in both directions. The supply voltage at which the triac starts conducting depends on the gate current. If the gate current is being greater, lesser will be the supply voltage at which the triac is turned ON. Above discussed mode - 1 triggering is used in the first quadrant whereas mode-3 triggering is used in 3rd quadrant. Due to the internal structure of the triac, the actual values of latching current, gate trigger current and holding current may be slightly different in different operating modes. Therefore, the ratings of the triacs considerably lower than the thyristors.

Advantages of Triac

Triac can be triggered by both positive and negative polarity voltages applied at the gate.

- It can operate and switch both half cycles of an AC waveform.
- As compared with the anti-parallel thyristor configuration which requires two heat sinks of slightly smaller size, a triac needs a single heat sink of slightly larger size. Hence the triac saves both space and cost in AC power applications.

- In DC applications, SCRs are required to be connected with a parallel diode to protect against reverse voltage. But the triac may work without a diode, a safe breakdown is possible in either direction.

Disadvantages of Triac

- These are available in lower ratings as compared with thyristors.
- A careful consideration is required while selecting a gate trigger circuit since a triac can be triggered in both forward and reverse biased conditions.
- These have low dv/dt rating as compared with thyristors.
- These have very small switching frequencies.
- Triacs are less reliable than thyristors.

Numerical Problems

1. A single phase voltage controller is employed for controlling the power flow from 230V, 50Hz source into a load circuit consisting of $R=3 \Omega$ and $\omega L=4 \Omega$. Calculate

- the range of firing angle
- the maximum value of rms load current
- the maximum power and power factor
- The maximum values of average and rms thyristor currents.

Solution:

- For controlling the load the minimum value of firing angle $\alpha =$ load phase angle

$$\varphi = \tan^{-1} \frac{\omega L}{R} = \tan^{-1} \frac{4}{3} = 53.13^\circ$$

The maximum possible value of α is 180°

So the firing angle control range is $53.13^\circ \leq \alpha \leq 180^\circ$

- The maximum value of rms value of load current occurs when $\alpha = \Phi = 53.13^\circ$
But at this value of firing angle, the power circuit of ac voltage controller behaves as if load is directly connected to ac source. Therefore maximum value of rms load current is

$$I_0 = \frac{230}{\sqrt{R^2 + (wL)^2}} = \frac{230}{\sqrt{3^2 + 4^2}} = 46A$$

iii. Maximum power = $I_0^2 \times R = 46^2 \times 3 = 6348W$

$$\text{Power factor} = \frac{I_0^2 \times R}{V_{slo} \times 230} = \frac{46 \times 3}{230} = 0.6$$

iv. Average thyristor current is maximum when $\alpha = \Phi$ and conduction angle $\gamma = M$

$$I_{TAVG} = \frac{1}{2\pi} \int_{\alpha}^{\alpha + \pi} \frac{V_m}{Z} \sin(\omega t - \phi) d(\omega t)$$

$$= \frac{V_m}{\pi Z} = \frac{\sqrt{2} \times 230}{\pi \times \sqrt{3^2 + 4^2}} = 20.707A$$

Similarly maximum value of thyristor current is

$$I_{Trms} = \frac{1}{\sqrt{2\pi}} \int_{\alpha}^{\alpha + \pi} \frac{V_m}{Z} \sin(\omega t - \alpha) d(\omega t)$$

$$= \frac{V_m}{2Z} = \frac{\sqrt{2} \times 230}{2 \times \sqrt{3^2 + 4^2}} = 32.527A$$

2. An ac voltage controller uses a TRIAC for phase angle control of a resistive load of 100Ω. Calculate the value of delay angle for having an rms load voltage of 220 volts. Also calculate the rms value of TRIAC current. Assume the rms supply voltage to be 230V.

3. The ac voltage controller uses on-off control for heating a resistive load of R = 4 ohms and the input voltage is Vs = 208V, 60Hz. If the desired output power is Po = 3KW, determine the

(a) duty cycle δ

(b) input power factor

Sketch waveforms for the duty cycle obtained in (a)

Introduction to Cyclo converters

The **Cycloconverter** has been traditionally used only in very high power drives, usually above one megawatt, where no other type of drive can be used. Examples are cement tube mill drives above 5 MW, the 13 MW German-Dutch wind tunnel fan drive, reversible rolling mill drives and ship propulsion drives. The reasons for this are that the traditional **Cycloconverter** requires a large number of thyristors, at least 36 and usually more for good motor performance, together with a very complex control circuit, and it has some performance limitations, the worst of which is an output frequency limited to about one third the input frequency .



Figure 3.11 Block diagram of cycloconverters

The **Cycloconverter** has four thyristors divided into a positive and negative bank of two thyristors each. When positive current flows in the load, the output voltage is controlled by phase control of the two positive bank thyristors whilst the negative bank thyristors are kept off and vice versa when negative current flows in the load. An idealized output waveform for a sinusoidal load current and a 45 degrees load phase angle is shown in Figure 3.11. It is important to keep the non conducting thyristor bank off at all times, otherwise the mains could be shorted via the two thyristor banks, resulting in waveform distortion and possible device failure from the shorting current. A major control problem of the **Cycloconverter** is how to swap between banks in the shortest possible time to avoid distortion whilst ensuring the two banks do not conduct at the same time. A common addition to the power circuit that removes the requirement to keep one bank off is to place a centre tapped inductor called a circulating current inductor between the outputs of the two banks. Both banks can now conduct together without shorting the mains. Also, the circulating current in the inductor keeps both banks operating all the time, resulting in improved output waveforms. This technique is not often used, though, because the circulating current inductor tends to be expensive and bulky and the circulating current reduces the power factor on the input

In a **1- ϕ Cycloconverter**, the output frequency is less than the supply frequency. These converters require natural commutation which is provided by AC supply. During positive half cycle of supply, Thyristors P1 and N2 are forward biased. First triggering pulse is applied to P1 and hence it starts conducting.

As the supply goes negative, P1 gets off and in negative half cycle of supply, P2 and N1 are forward biased. P2 is triggered and hence it conducts. In the next cycle of supply, N2 in positive half cycle and N1 in negative half cycle are triggered. Thus, we can observe that here the output frequency is 1/2 times the supply frequency.

Operation Principles

The following sections will describe the operation principles of the **Cycloconverter** starting from the simplest one, **single-phase to single-phase (1f-1f) Cycloconverter**.

Single-phase to Single-phase (1 Φ -1 Φ) Cycloconverter

To understand the operation principles of **Cycloconverters**, the single-phase to single-phase **Cycloconverter** (Fig. 3.12) should be studied first. This converter consists of back-to-back connection of two full-wave rectifier circuits. Fig 3.13 shows the operating waveforms for this converter with a resistive load.

Zero Firing angle, i.e. thyristors act like diodes. Note that the firing angles are named as α_P for the positive converter and α_N for the negative converter. The input voltage, v_s is an ac voltage at a frequency, f_i as shown in Fig. 3.13. For easy understanding assume that all the thyristors are fired at $\alpha=0^\circ$

Consider the operation of the **Cycloconverter** to get one-fourth of the input frequency at the output. For the first two cycles of v_s , the positive converter operates supplying current to the load. It rectifies the input voltage; therefore, the load sees 4 positive half cycles as seen in Fig.

3.13. In the next two cycles, the negative converter operates supplying current to the load in the reverse direction. The current waveforms are not shown in the figures because the resistive load current will have the same waveform as the voltage but only scaled by the resistance. Note that when one of the converters operates the other one is disabled, so that there is no current circulating between the two rectifiers.

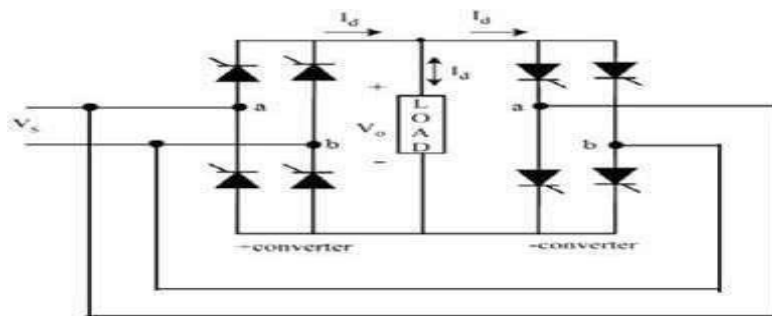

Figure 3.12 circuit diagram of cycloconverter

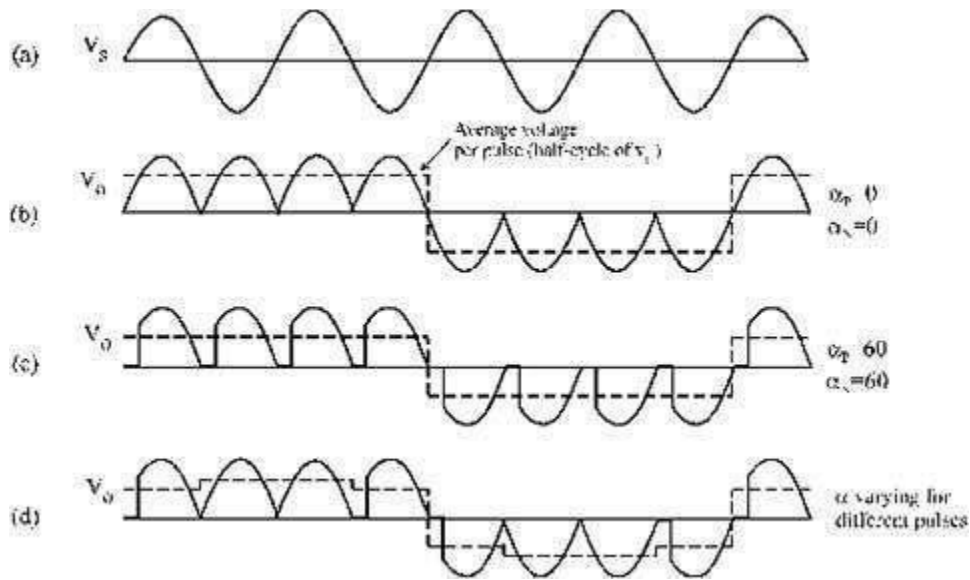

Figure 3.13 Input and output waveforms of cycloconverter

Single phase midpoint Cyclo converters

Basically, these are divided into two main types, and are given below

Step-down cyclo-converter

It acts like a step-down transformer that provides the output frequency less than that of input, $f_o < f_i$.

Step-up cyclo-converter

It provides the output frequency more than that of input, $f_o > f_i$.

In case of step-down cyclo-converter, the output frequency is limited to a fraction of input frequency, typically it is below 20Hz in case 50Hz supply frequency. In this case, no separate commutation circuits are needed as SCRs are line commutated devices.

But in case of step-up cyclo-converter, forced commutation circuits are needed to turn OFF SCRs at desired frequency. Such circuits are relatively very complex. Therefore, majority of cyclo-converters are of step-down type that lowers the frequency than input frequency.

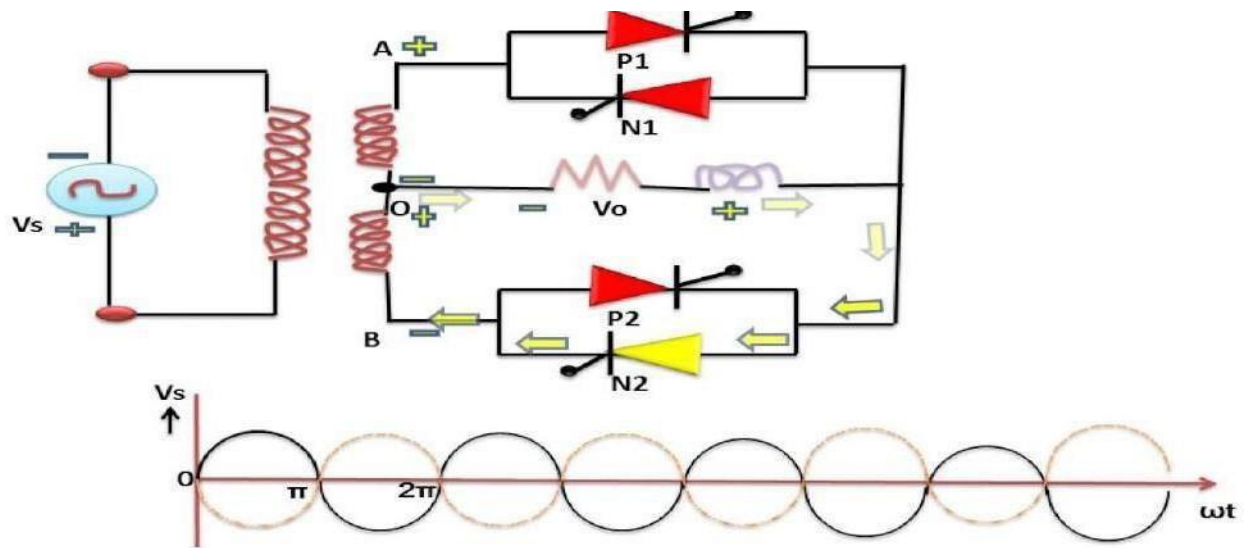

Figure 3.14 circuit diagram of midpoint cycloconverter

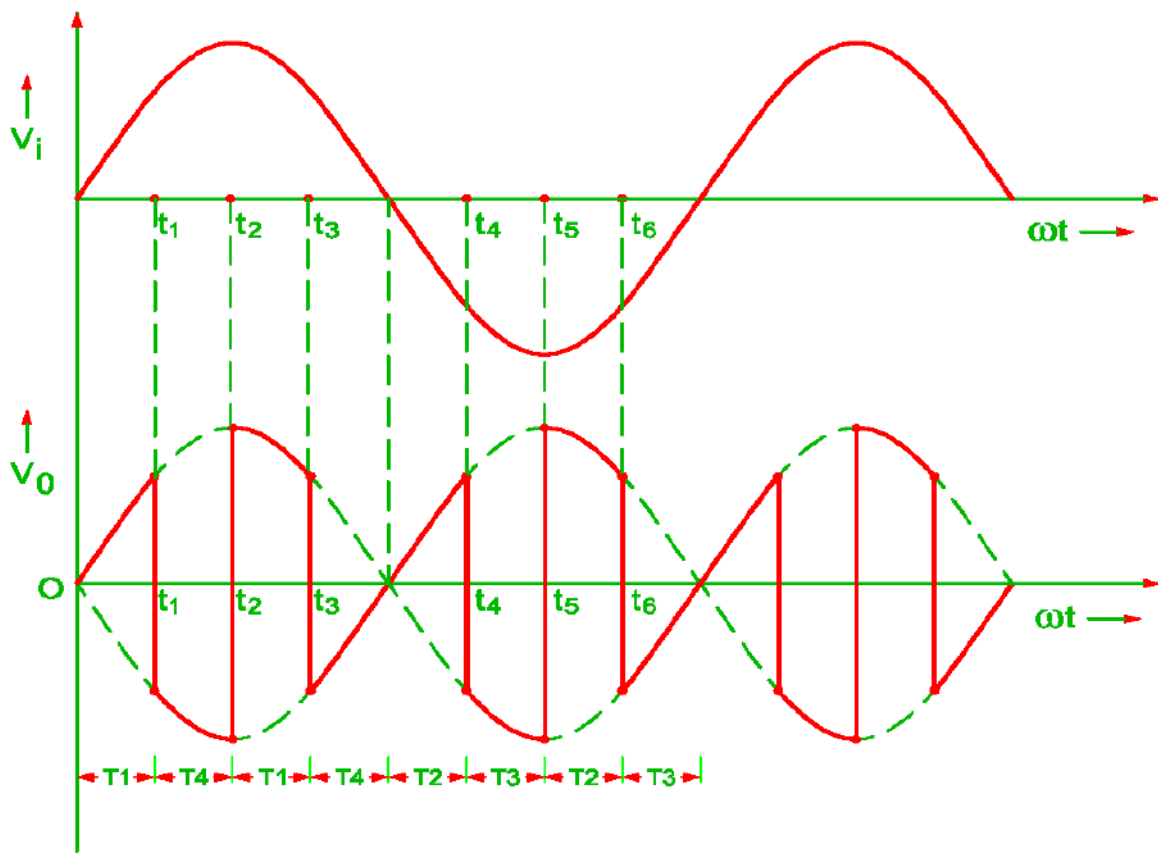

Figure 3.15 Input and output waveforms of midpoint cycloconverter

It consists of single phase transformer with mid tap on the secondary winding and four thyristors. Two of these thyristors P1, P2 are for positive group and the other two N1, N2 are for the negative group. Load is connected between secondary winding midpoint 0 and the load terminal. Positive directions for output voltage and output current are marked in figure 3.14

In figure 3.14 during the positive half cycle of supply voltage terminal a is positive with respect to terminal b. therefore in this positive half cycle, both p1 and N2 are forward biased from $\omega t = 0$ to Π . As such SCR P1 is turned on at $\omega t = 0$ so that load voltage is positive with terminal A and 0 negative. Now the load voltage is positive. At instant t_1 P1 is force commutated and forward biased thyristor N2 is turned on so that load voltage is negative with terminal 0 and A negative. Now the load voltage is negative. Now N2 is force commutated and P1 is turned on the load voltage is positive this is a continuous process and will get step up cyclo converter output

Bridge configuration of single phase Cyclo converter

The equivalent circuit of a cyclo-converter is shown in figure below. Here each two quadrant phase controlled converter is represented by a voltage source of desired frequency and consider that the output power is generated by the alternating current and voltage at desired frequency.

The diodes connected in series with each voltage source represent the unidirectional conduction of each two quadrant converter. If the output voltage ripples of each converter are neglected, then it becomes ideal and represents the desired output voltage.

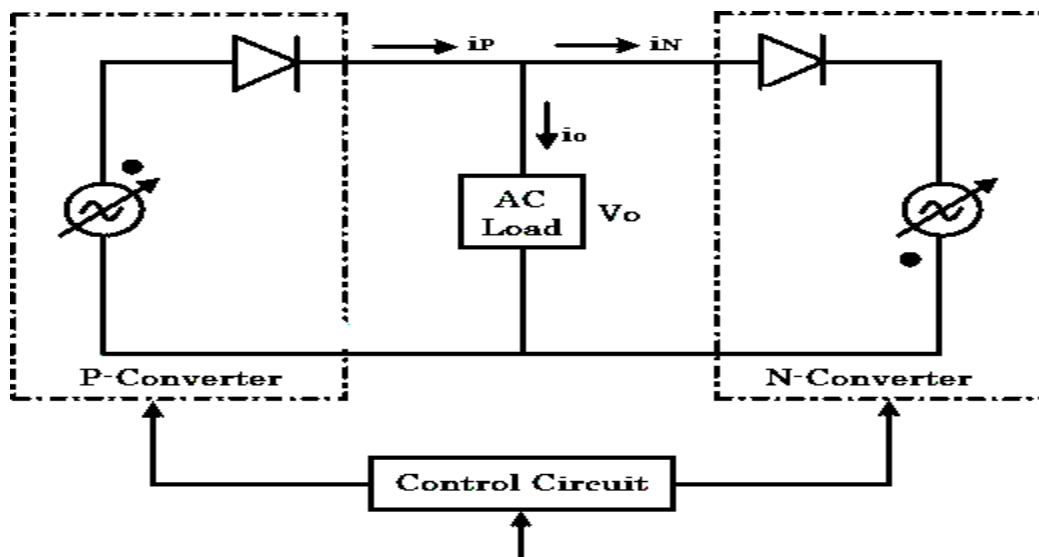

Figure 3.16 Block diagram of bridge type cycloconverter

If the firing angles of individual converters are modulated continuously, each converter produces same sinusoidal voltages at its output terminals.

So the voltages produced by these two converters have same phase, voltage and frequency. The average power produced by the cyclo-converter can flow either to or from the output terminals as the load current can flow freely to and from the load through the positive and negative converters.

Therefore, it is possible to operate the loads of any phase angle (or power factor), inductive or capacitive through the cyclo-converter circuit.

Due to the unidirectional property of load current for each converter, it is obvious that positive converter carries positive half-cycle of load current with negative converter remaining in idle during this period.

Similarly, negative converter carries negative half cycle of the load current with positive converter remaining in idle during this period, regardless of the phase of current with respect to voltage.

This means that each converter operates both in rectifying and inverting regions during the period of its associated half cycles.

The figure below shows ideal output current and voltage waveforms of a cyclo-converter for lagging and leading power factor loads. The conduction periods of positive and negative converters are also illustrated in the figure.

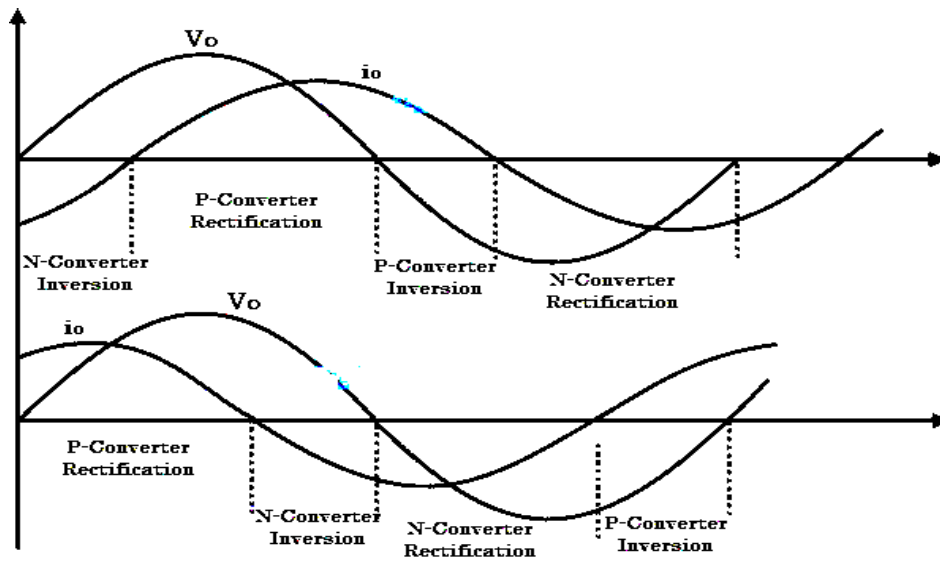

Figure 3.17 cycloconverter waveforms

The positive converter operates whenever the load current is positive with negative converter remaining in idle. In the same manner negative converter operates for negative half cycle of load current.

Both rectification and inversion modes of each converter are shown in figure. This desired output voltage is produced by regulating the firing angle to individual converters.

Single-phase to single-phase cyclo-converters

These are rarely used in practice; however, these are required to understand fundamental principle of cyclo-converters.

It consists of two full-wave, fully controlled bridge thyristors, where each bridge has 4 thyristors, and each bridge is connected in opposite direction (back to back) such that both positive and negative voltages can be obtained as shown in figure below. Both these bridges are excited by single phase, 50 Hz AC supply.

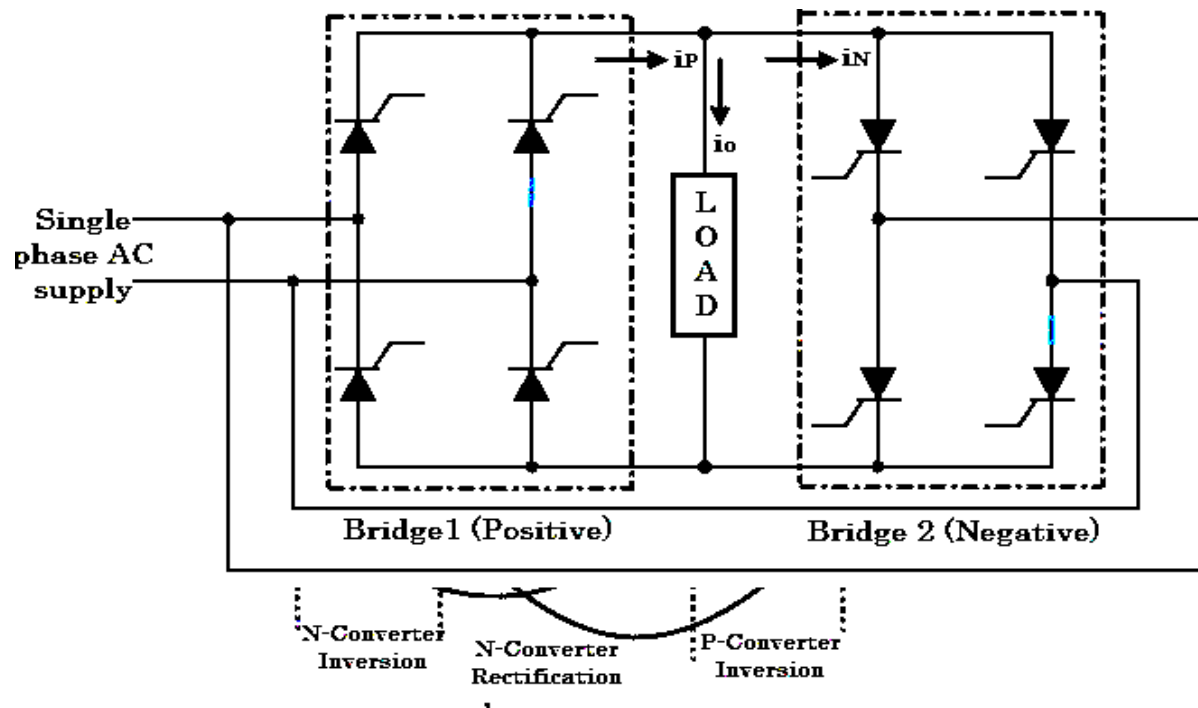

Figure 3.18 Circuit diagram of bridge type cycloconverter

During positive half cycle of the input voltage, positive converter (bridge-1) is turned ON and it supplies the load current. During negative half cycle of the input, negative bridge is turned ON and it supplies load current. Both converters should not conduct together that cause short circuit at the input.

To avoid this, triggering to thyristors of bridge-2 is inhibited during positive half cycle of load current, while triggering is applied to the thyristors of bridge-1 at their gates. During negative half cycle of load current, triggering to positive bridge is inhibited while applying triggering to negative bridge.

By controlling the switching period of thyristors, time periods of both positive and negative half cycles are changed and hence the frequency. This frequency of fundamental output voltage can be easily reduced in steps, i.e., 1/2, 1/3, 1/4 and so on.

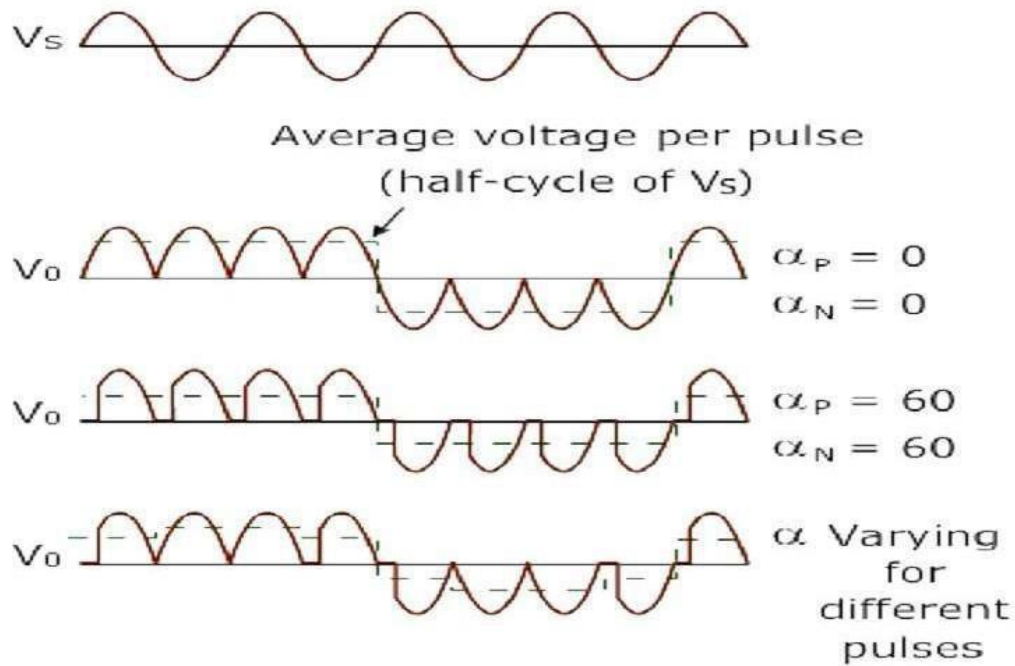

Figure 3.19 Input and output waveforms of bridge type cycloconverter

The above figure shows output waveforms of a cyclo-converter that produces one-fourth of the input frequency. Here, for the first two cycles, the positive converter operates and supplies current to the load.

It rectifies the input voltage and produce unidirectional output voltage as we can observe four positive half cycles in the figure. And during next two cycles, the negative converter operates and supplies load current.

Here current waveforms are not shown because it is a resistive load in where current (with less magnitude) exactly follows the voltage.

Here one converter is disabled if another one operates, so there is no circulating current between two converters. Since the discontinuous mode of control scheme is complicated, most cyclo-converters are operated on circulating current mode where continuous current is allowed to flow between the converters with a reactor.

This circulating current type cyclo-converter can be operated on with both purely resistive (R) and inductive (R-L) loads.

1. A single-phase to single-phase cycloconverter is supplying an inductive load comprising of a Resistance of 5Ω and an inductance of 40 mH from a 230 V , 50 Hz single-phase supply. It is required to provide an output frequency which is $1/3$ of the input frequency. If the converters are operated as semi converter such that $0 \leq \alpha \leq \pi$ and firing delay angle is 120° . Neglecting the harmonic content of load voltage, determine:
 - (a) rms value of output voltage.
 - (b) rms current of each thyristor and
 - (c) input power factor.

Solution:

$$E = 230\text{ V}, f_1 = 50\text{ Hz}, \alpha_p = \frac{2\pi}{3}$$

$$f_0 = 50/2 = 16.2/3\text{ Hz}, R = 5\Omega, L = 40\text{ mH}$$

$$\omega_0 = 2\pi \times 50/3 = 104.72\text{ rad/s}$$

$$X_L = \omega_0 L = 104.72 \times 40 \times 10^{-3} = 4.188\ \Omega$$

$$Z_L = \sqrt{5^2 + (4.188)^2} = 6.52\ \Omega$$

$$\theta = \tan^{-1}(\omega_0 L/R) \cong 40^\circ$$

(a) For $0 \leq \alpha \leq \pi$, rms value of output voltage,

$$\begin{aligned} E_o &= E \cdot \left[\frac{1}{\pi} \left(\pi - \alpha_p + \frac{\sin 2\alpha_p}{2} \right) \right]^{1/2} \\ &= 230 \cdot \left[\frac{1}{\pi} \left\{ \left(\pi - \frac{2\pi}{3} \right) + \frac{\sin 240}{2} \right\} \right]^{1/2} \\ &= 101.6\text{ V} \end{aligned}$$

(b) RMS value of load current, $I_o = \frac{E_o}{Z_L}$

$$= \frac{101.6}{4.188} = 24.26\text{ A}$$

The rms current through each converter group is

$$I_P = I_N = \frac{I_o}{\sqrt{2}} = 17.1542 \text{ A.}$$

and the rms current through each thyristor

$$I_{T_{rms}} = \frac{I_p}{\sqrt{2}} = \frac{17.1542}{\sqrt{2}} = 12.13 \text{ A.}$$

(c) rms input current, $I_i = I_o = 24.26 \text{ A.}$

The volt-amp rating = $E \cdot I_i = 230 \times 24.26 = 5580 \text{ VA}$

The output power, $P_o = E_o \cdot I_o \cdot \cos \theta = 101.6 \times 24.26 \times \cos 40^\circ$
 $= 1888.1 \text{ watts.}$

$$\therefore \text{Power factor} = \frac{P_o}{E \cdot I_i} = \frac{1888}{5580}$$

$$= 0.3384 \text{ (lagging)}$$

Now,
$$\text{P.F.} = \frac{m_f}{\sqrt{2}} \cdot \cos \phi$$

$$m_f = \cos (180 - \alpha_p) = \cos 60^\circ = 0.5$$

$$\cos \phi = \cos 40 = 0.766.$$

Hence,
$$P_f = \frac{0.5}{\sqrt{2}} \cdot \cos 40 = 0.27$$

2. In a standard A single-phase bridge-type cyclo-converter has input voltage of 230V, 50Hz and load of $R=10\Omega$. Output frequency is one-third of input frequency. For a firing angle delay of 30° , Calculate (i) rms value of output voltage (ii) rms current of each converter (iii) rms current of each thyristor (iv) input power factor.
3. A single-phase to single-phase mid-point cyclo-converter is delivering power to a resistive load. The supply transformer has turns ratio of 1: 1: 1. The frequency ratio is $f_o/f_s = 1/5$. The firing angle delay α for all the four SCRs are the same. Sketch the time variations of the following waveforms for $\alpha = 0^\circ$ and $\alpha = 30^\circ$ (a) Supply voltage (b) Output current and (c) Supply current. Indicate the conduction of various thyristors also.

UNIT – IV

DC – DC converters

Introduction to Choppers

A chopper uses high speed to connect and disconnect from a source load. A fixed DC voltage is applied intermittently to the source load by continuously triggering the power switch ON/OFF. The period of time for which the power switch stays ON or OFF is referred to as the chopper's ON and OFF state times, respectively.

Choppers are mostly applied in electric cars, conversion of wind and solar energy, and DC motor regulators.

Symbol of a Chopper

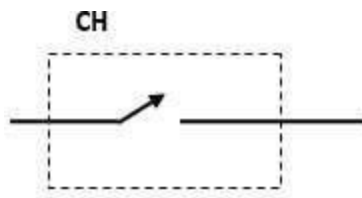

Figure: 3.1 symbol of chopper

Control strategies of Chopper

In DC-DC converters, the average output voltage is controlled by varying the alpha (α) value. This is achieved by varying the Duty Cycle of the switching pulses. Duty cycle can be varied usually in 2 ways:

1. Time Ratio Control
2. Current Limit Control

In this post we shall look upon both the ways of varying the duty cycle. Duty Cycle is the ratio of 'On Time' to 'Time Period of a pulse'.

Time Ratio Control: As the name suggest, here the time ratio (i.e. the duty cycle ratio T_{on}/T) is varied. This kind of control can be achieved using 2 ways:

- Pulse Width Modulation (PWM)
- Frequency Modulation Control (FMC)

Pulse Width Modulation (PWM)

In this technique, the time period is kept constant, but the 'On Time' or the 'OFF Time' is varied. Using this, the duty cycle ratio can be varied. Since the ON time or the 'pulse width' is getting changed in this method, so it is popularly known as Pulse width modulation.

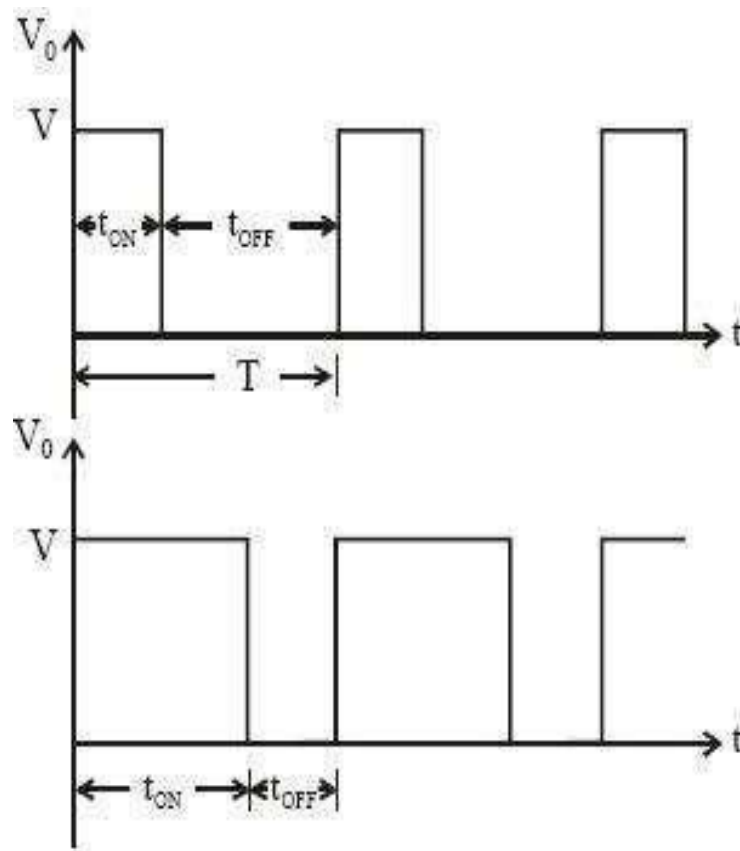

Figure: 3.2 pulse width modulation waveforms

Frequency Modulation Control (FMC)

In this control method, the 'Time Period' is varied while keeping either of 'On Time' or 'OFF time' as constant. In this method, since the time period gets changed, so the frequency also changes accordingly, so this method is known as frequency modulation control.

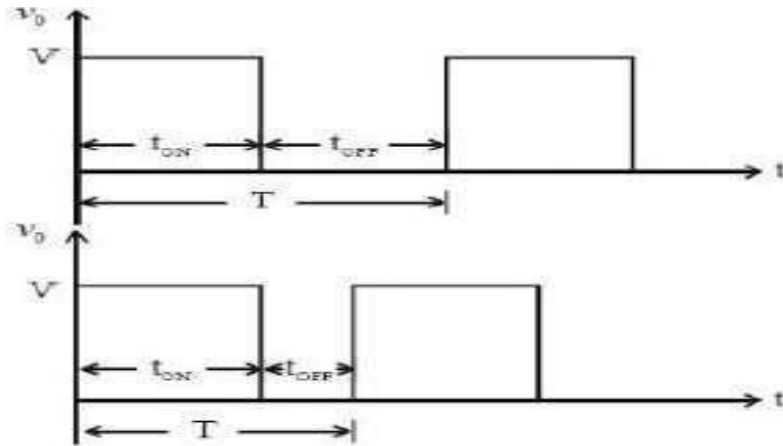

Figure: 3.3 Frequency modulation waveforms

Current Limit Control:

As is obvious from its name, in this control strategy, a specific limit is applied on the current variation.

In this method, current is allowed to fluctuate or change only between 2 values i.e. maximum current (I_{max}) and minimum current (I_{min}). When the current is at minimum value, the chopper is switched ON. After this instance, the current starts increasing, and when it reaches up to maximum value, the chopper is switched off allowing the current to fall back to minimum value. This cycle continues again and again.

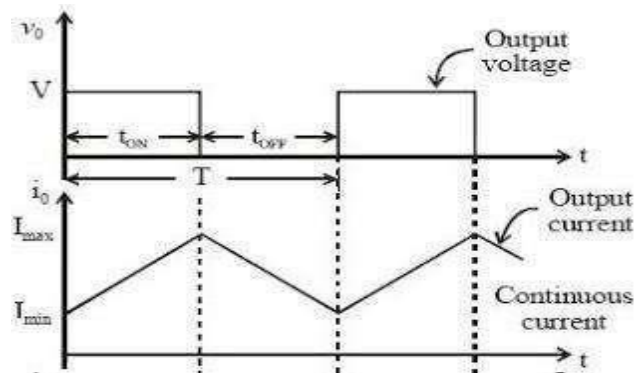

Figure: 3.4 current limit control waveforms

Classification of Choppers

Depending on the voltage output, choppers are classified as –

1. Step Up chopper (boost converter)
2. Step Down Chopper(Buck converter)

3. Step Up/Down Chopper (Buck-boost converter)

Depending upon the direction of the output current and voltage, the converters can be classified into five classes namely

1. Class A [One-quadrant Operation]
2. Class B [One-quadrant Operation]
3. Class C [Two-quadrant Operation]
4. Class D Chopper [Two-quadrant Operation]
5. Class E Chopper [Four-quadrant Operation]

StepDown Chopper

This is also known as a buck converter. In this chopper, the average voltage output V_o is less than the input voltage V_s . When the chopper is ON, $V_o = V_s$ and when the chopper is off, $V_o = 0$

When the chopper is ON –

$$V_s = (V_L + V_o), \quad V_L = V_s - V_o,$$

$$L \frac{di}{dt} = V_s - V_o,$$

$$L \Delta i / T_{ON} = V_s - V_o$$

$$V_s = (V_L + V_o),$$

$$V_L = V_s - V_o,$$

$$L \frac{di}{dt} = V_s - V_o,$$

$$L \Delta i / T_{ON} = V_s - V_o$$

Thus, peak-to-peak current load is given by,

$$\Delta i = \frac{V_s - V_o}{L} T_{ON}$$

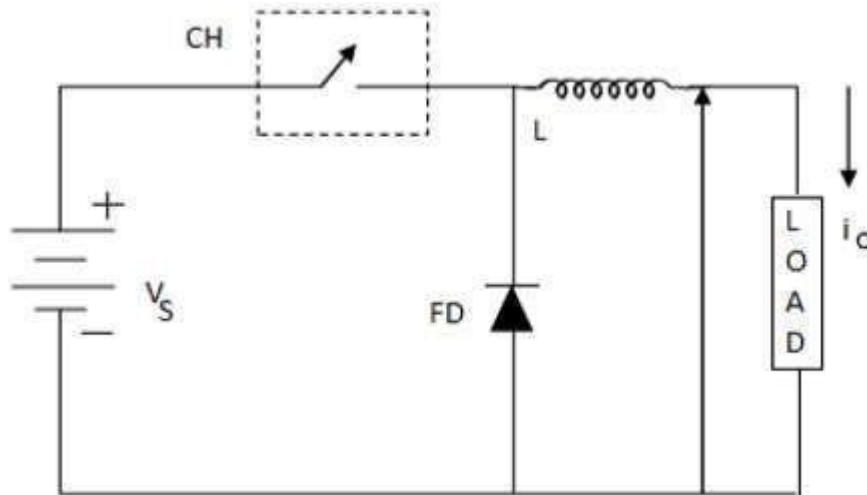

Figure: 3.5 Step down chopper

Where **FD** is free-wheel diode.

When the chopper is OFF, polarity reversal and discharging occurs at the inductor. The current passes through the free-wheel diode and the inductor to the load. This gives,

$$L \frac{di}{dt} = -V_0$$

$$\text{Rewritten as } L \Delta i / T_{OFF} = -V_0$$

$$L \Delta i / T_{OFF} = -V_0$$

$$\Delta i = -V_0 T_{OFF} / L$$

From the above equations

$$\frac{V_S - V_0}{L} T_{ON} = \frac{V_0}{L} T_{OFF}$$

$$\frac{V_S - V_0}{V_0} = \frac{T_{OFF}}{T_{ON}}$$

$$\frac{V_S}{V_0} = \frac{T_{ON} + T_{OFF}}{T_{ON}}$$

$$V_0 = \frac{T_{ON}}{T} V_S = D V_S$$

$$\begin{aligned} \Delta i &= \frac{V_S - D V_S}{L} D T, \text{ from } D = \frac{T_{ON}}{T} \\ &= \frac{V_S (1 - D) D}{L f} \end{aligned}$$

$$f = \frac{1}{T} = \text{chopping frequency}$$

Current and Voltage Waveforms

The current and voltage waveforms are given below –

For a step down chopper the voltage output is always less than the voltage input. This is shown by the waveform below.

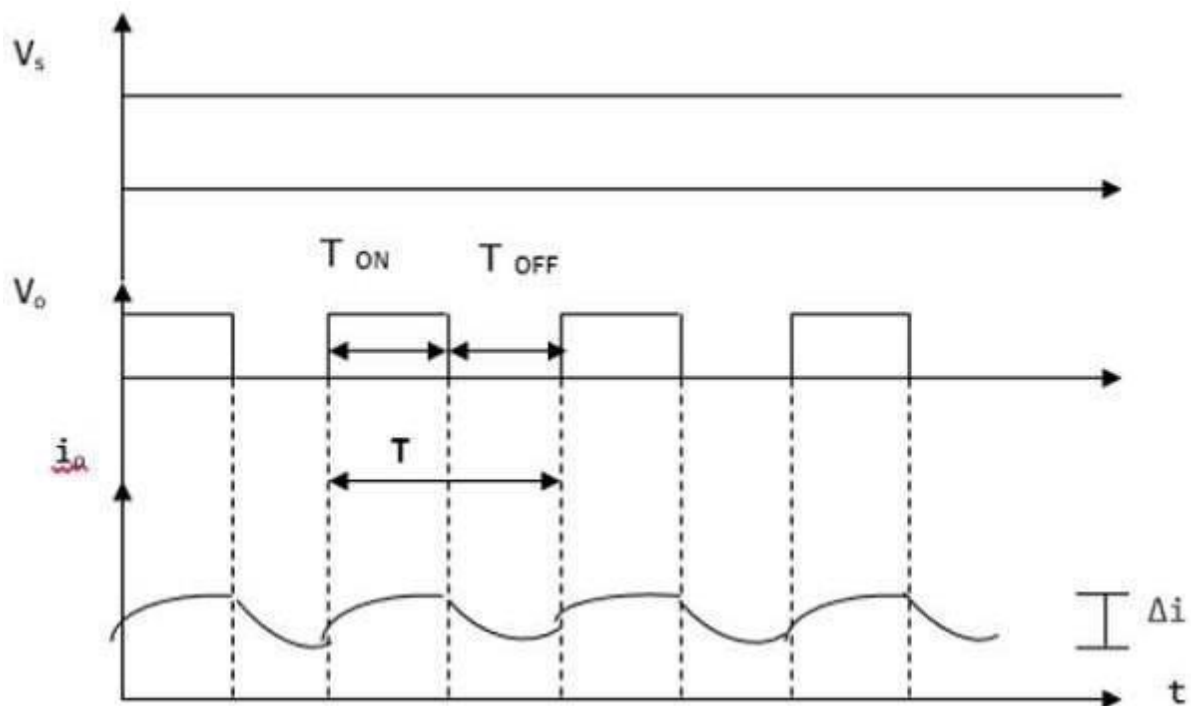

Figure: 3.6 Input and output waveforms

StepUpChopper

The average voltage output (V_o) in a step up chopper is greater than the voltage input (V_s). The figure below shows a configuration of a step up chopper.

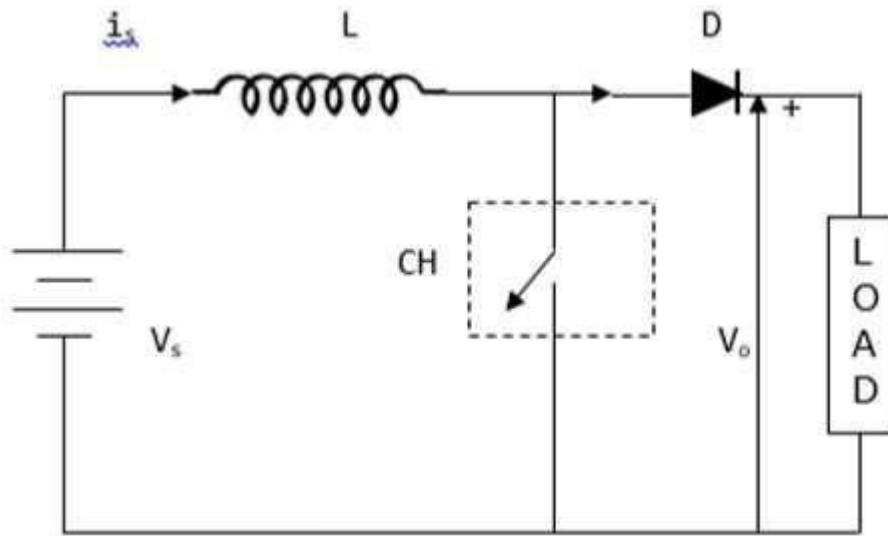

Figure: 3.7 circuit diagram of step up chopper

Current and Voltage Waveforms

V_o (average voltage output) is positive when chopper is switched ON and negative when the chopper is OFF as shown in the waveform below.

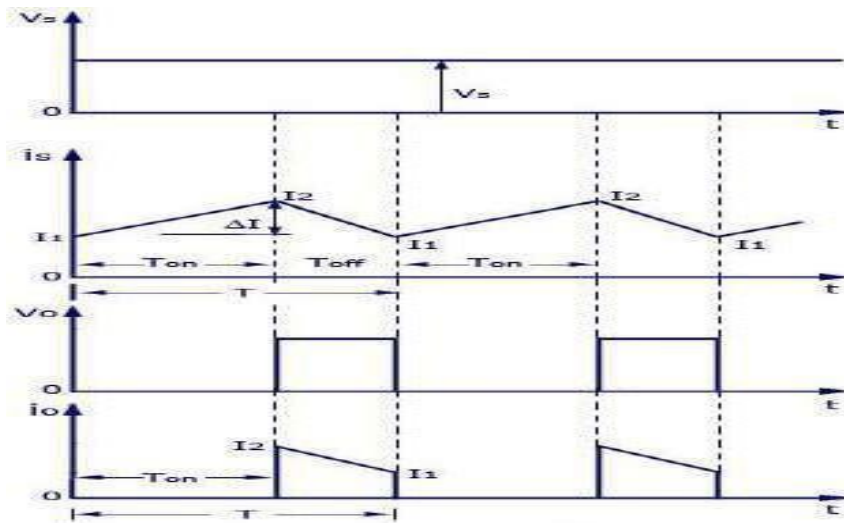

Figure: 3.8 Input and output waveforms of step up chopper

Where

T_{ON} – time interval when chopper is ON

T_{OFF} – time interval when chopper is OFF

V_L – Load voltage

V_s – Source voltage

T – Chopping time period = $T_{ON} + T_{OFF}$

V_o is given by –

$$V_o = \frac{1}{T} \int_0^{T_{on}} V_s dt$$

When the chopper (CH) is switched ON, the load is short circuited and, therefore, the voltage output for the period T_{ON} is zero. In addition, the inductor is charged during this time. This gives $V_s = V_L$

$$V_s = L \frac{di}{dt}, \frac{\Delta i}{T_{on}} = \frac{V_s}{L}$$

$$\Delta i = \frac{V_s}{L} \times T_{on}$$

Δi = is the inductor peak to peak current. When the chopper (CH) is OFF, discharge occurs through the inductor L. Therefore, the summation of the V_s and V_L is given as follows –

$$V_o = V_s + V_L, V_L = V_o - V_s$$

$$L \frac{di}{dt} = V_o - V_s$$

$$L \frac{\Delta i}{T_{off}} = V_o - V_s$$

$$\Delta i = \frac{V_o - V_s}{L} T_{off}$$

Equating Δi from on state to off state

$$\frac{V_s}{L} \times T_{on} = \frac{V_o - V_s}{L} T_{off}$$

$$V_o = \frac{TV_s}{T_{off}}$$

$$V_o = \frac{V_s}{1 - D}$$

StepUp/StepDownChopper

his is also known as a buck-boost converter. It makes it possible to increase or reduce the voltage input level. The diagram below shows a buck-boost chopper

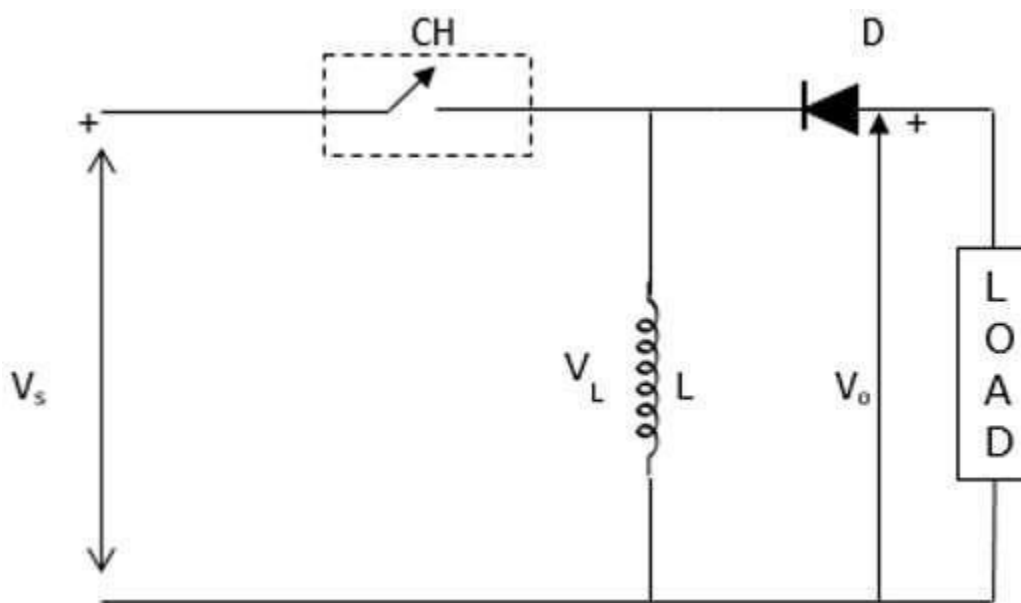

Figure: 3.9 circuit diagram of step up chopper

When the chopper is switched ON, the inductor L becomes charged by the source voltage V_s . Therefore, $V_s = V_L$.

$$V_s = L \frac{di}{dt}, \frac{\Delta i}{T_{on}} = \frac{V_s}{L}$$

$$\Delta i = \frac{V_s}{L} T_{on} \times \frac{T}{T}$$

$$\Delta i = \frac{DV_s}{Lf}$$

When the chopper is switched OFF, the inductor's polarity reverses and this causes it to discharge through the diode and the load.

Hence,

$$V_0 = -V_L$$

$$L \frac{di}{dt} = -V_L$$

$$\frac{L\Delta i}{T_{off}} = -V_L$$

$$\Delta i = -\frac{V_L T_{off}}{L}$$

By comparing the above equations

$$\frac{DV_s}{L_f} = -\frac{V_L T_{off}}{L}$$

$$V_0 = \frac{DV_s}{1-D}$$

Principle of operation of class A chopper

Class A Chopper is a first quadrant chopper

- When chopper is ON, supply voltage V is connected across the load.
- When chopper is OFF, $v_0 = 0$ and the load current continues to flow in the same direction through the FWD.
- The average values of output voltage and current are always positive. Class A Chopper is a first quadrant chopper
- When chopper is ON, supply voltage V is connected across the load.
- When chopper is OFF, $v_0 = 0$ and the load current continues to flow in the same direction through the FWD.
- The average values of output voltage and current are always positive.
- Class A Chopper is a step-down chopper in which power always flows from source to load.
- It is used to control the speed of dc motor.
- The output current equations obtained in step down chopper with R-L load can be used to study the performance of Class A Chopper.

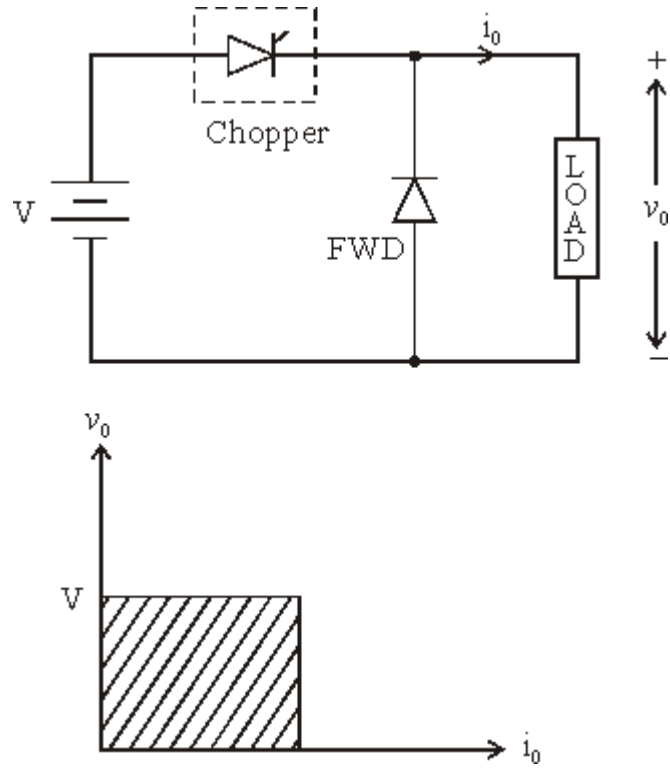

Figure: 3.10 circuit diagram and quadrant operation of Type A chopper

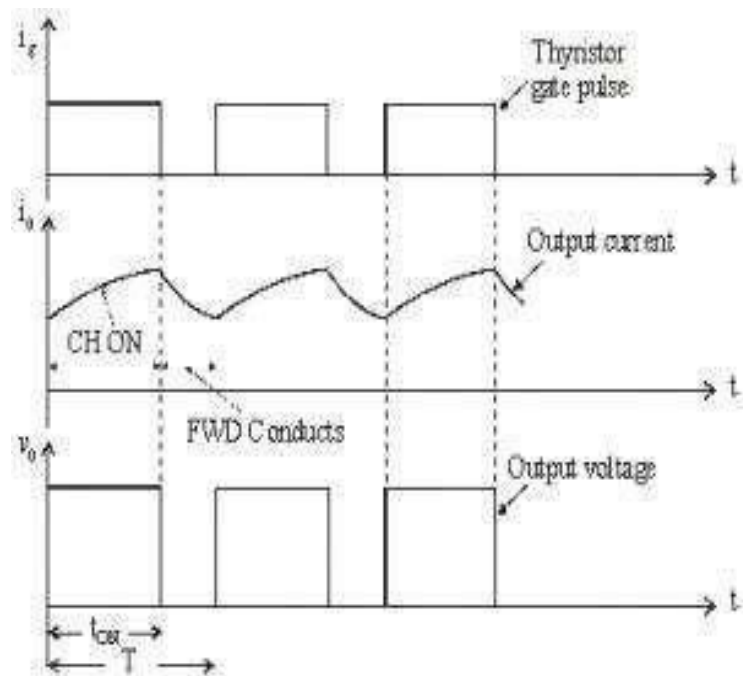

Figure: 3.11 Output voltage and current waveforms of type A chopper

Voltage equation for the circuit shown in figure is

$$V = i_o R + L \frac{di_o}{dt} + E$$

Taking Laplace Transform

$$\frac{V}{S} = RI_o(S) + L [SI_o(S) - i_o(0^-)] + \frac{E}{S}$$

At $t = 0$, initial current $i_o(0^-) = I_{\min}$

$$I_o(S) = \frac{V - E}{LS \left(S + \frac{R}{L} \right)} + \frac{I_{\min}}{S + \frac{R}{L}}$$

Taking Inverse Laplace Transform

$$i_o(t) = \frac{V - E}{R} \left[1 - e^{-\left(\frac{R}{L}\right)t} \right] + I_{\min} e^{-\left(\frac{R}{L}\right)t}$$

This expression is valid for $0 \leq t \leq t_{ON}$. i.e., during the period chopper is ON.

At the instant the chopper is turned off, load current is

$$i_o(t_{ON}) = I_{\max}$$

When Chopper is OFF ($0 \leq t \leq t_{OFF}$)

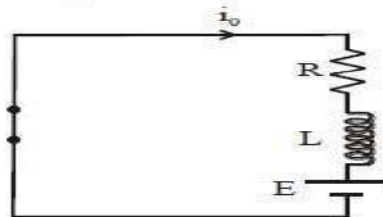

Voltage equation for the circuit shown in figure is

$$0 = Ri_o + L \frac{di_o}{dt} + E$$

Taking Laplace transform

$$0 = RI_o(S) + L [SI_o(S) - i_o(0^-)] + \frac{E}{S}$$

Redefining time origin we have at $t = 0$, initial current $i_o(0^-) = I_{\max}$

Therefore
$$I_o(S) = \frac{I_{\max}}{S + \frac{R}{L}} - \frac{E}{LS \left(S + \frac{R}{L} \right)}$$

Taking Inverse Laplace Transform

$$i_o(t) = I_{\max} e^{-\frac{R}{L}t} - \frac{E}{R} \left[1 - e^{-\frac{R}{L}t} \right]$$

The expression is valid for $0 \leq t \leq t_{OFF}$, i.e., during the period chopper is OFF. At the instant the chopper is turned ON or at the end of the off period, the load current is

$$i_o(t_{OFF}) = I_{\min}$$

TO FIND I_{\max} AND I_{\min}

At $t = t_{ON} = dT$, $i_o(t) = I_{\max}$

Class B Chopper

Class B Chopper is a step-up chopper

- When chopper is ON, E drives a current through L and R in a direction opposite to that shown in figure.
- During the ON period of the chopper, the inductance L stores energy.
- When Chopper is OFF, diode D conducts, and part of the energy stored in inductor L is returned to the supply.
- Average output voltage is positive. Average output current is negative.
- Therefore Class B Chopper operates in second quadrant.
- In this chopper, power flows from load to source.
- Class B Chopper is used for regenerative braking of dc motor.

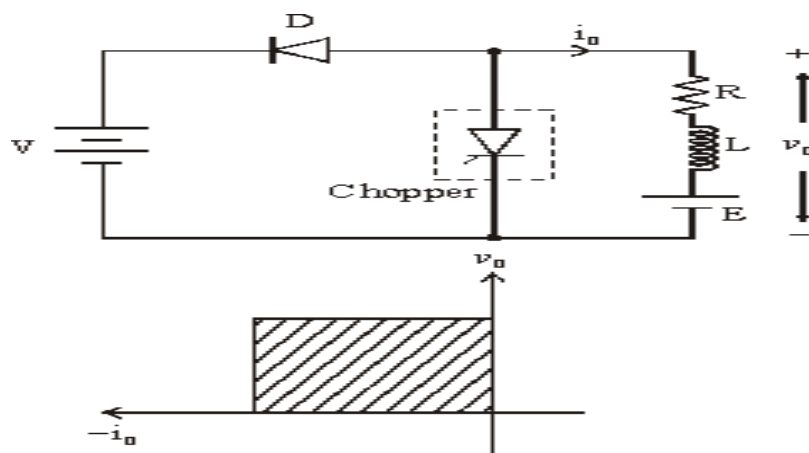

Figure: 3.12 circuit diagram and quadrant operation of Type B chopper

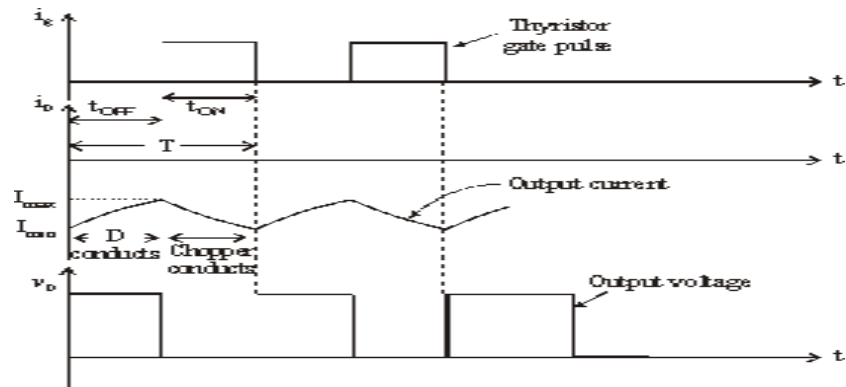

Figure: 3.13 Output voltage and current waveforms of type B chopper

Class C chopper

Class C Chopper can be used as a step-up or step-down chopper

- Class C Chopper is a combination of Class A and Class B Choppers.
- For first quadrant operation, CH1 is ON or D2 conducts.
- For second quadrant operation, CH2 is ON or D1 conducts.
- When CH1 is ON, the load current is positive.
- The output voltage is equal to 'V' & the load receives power from the source.
- When CH1 is turned OFF, energy stored in inductance L forces current to flow through the diode D2 and the output voltage is zero.
- Current continues to flow in positive direction.
- When CH2 is triggered, the voltage E forces current to flow in opposite direction through L and CH2 .
- The output voltage is zero.
- On turning OFF CH2 , the energy stored in the inductance drives current through diode D1 and the supply
- Output voltage is V, the input current becomes negative and power flows from load to source.
- Average output voltage is positive
- Average output current can take both positive and negative values.
- Choppers CH1 & CH2 should not be turned ON simultaneously as it would result in short circuiting the supply.
- Class C Chopper can be used both for dc motor control and regenerative braking of dc motor.

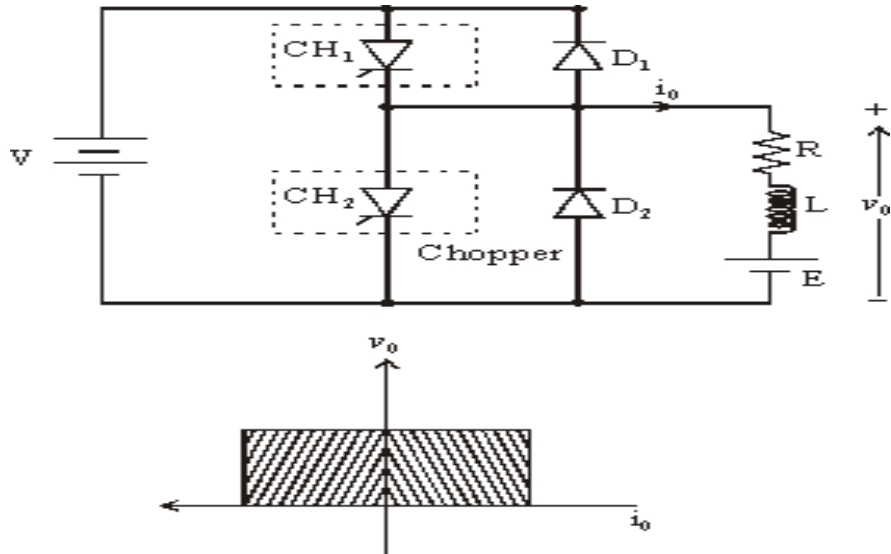

Figure: 3.14 circuit diagram and quadrant operation of Type C chopper

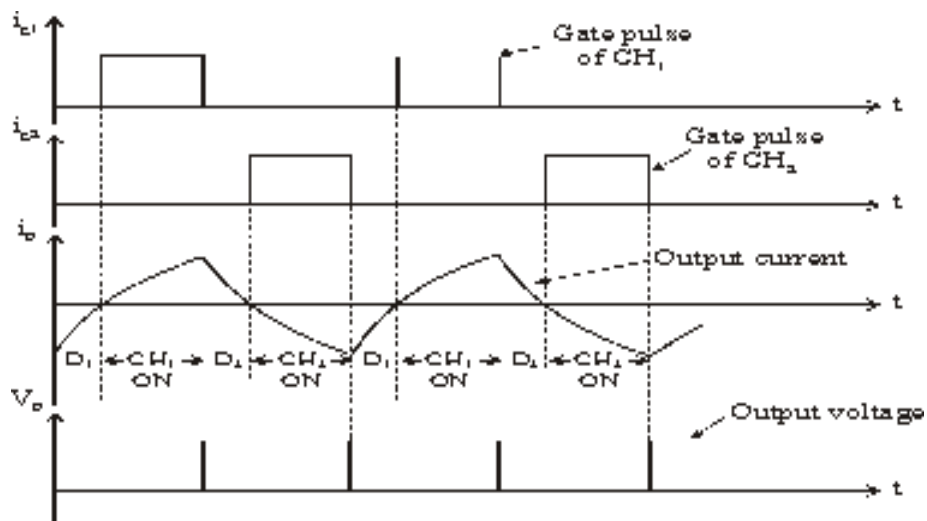

Figure: 3.15 Output voltage and current waveforms of type C chopper

Class D chopper

- Class D is a two quadrant chopper.
- When both CH1 and CH2 are triggered simultaneously, the output voltage $v_o = V$ and output current flows through the load.
- When CH1 and CH2 are turned OFF, the load current continues to flow in the same direction through load, D1 and D2, due to the energy stored in the inductor L.

- Output voltage $v_o = -V$.
- Average load voltage is positive if chopper ON time is more than the OFF time
- Average output voltage becomes negative if $t_{ON} < t_{OFF}$.
- Hence the direction of load current is always positive but load voltage can be positive or negative.

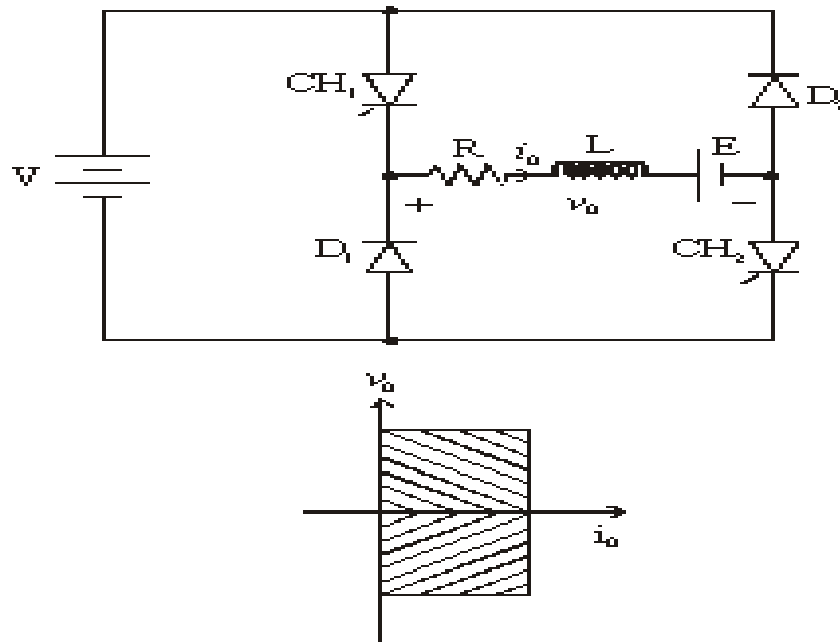

Figure: 3.16 circuit diagram and quadrant operation of Type D chopper

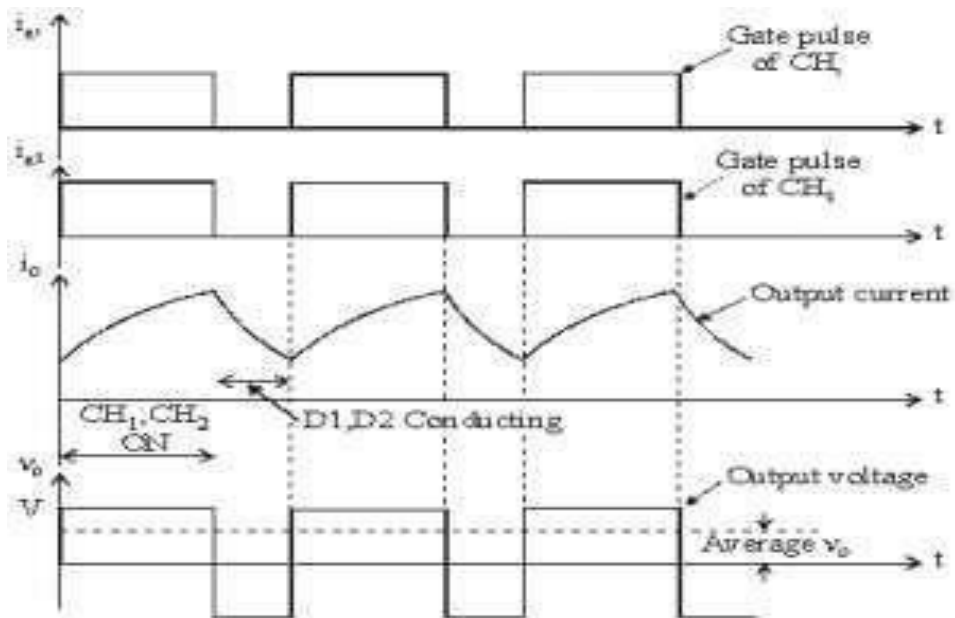

Figure: 3.17 Output voltage and current waveforms of type D chopper

Class E Chopper

- Class E is a four quadrant chopper
- When CH1 and CH4 are triggered, output current i_o flows in positive direction through CH1 and CH4, and with output voltage $v_o = V$.
- This gives the first quadrant operation.
- When both CH1 and CH4 are OFF, the energy stored in the inductor L drives i_o through D2 and D3 in the same direction, but output voltage $v_o = -V$.
- Therefore the chopper operates in the fourth quadrant.
- When CH2 and CH3 are triggered, the load current i_o flows in opposite direction & output voltage $v_o = -V$.
- Since both i_o and v_o are negative, the chopper operates in third quadrant.
- When both CH2 and CH3 are OFF, the load current i_o continues to flow in the same direction D1 and D4 and the output voltage $v_o = V$.
- Therefore the chopper operates in second quadrant as v_o is positive but i_o is negative.

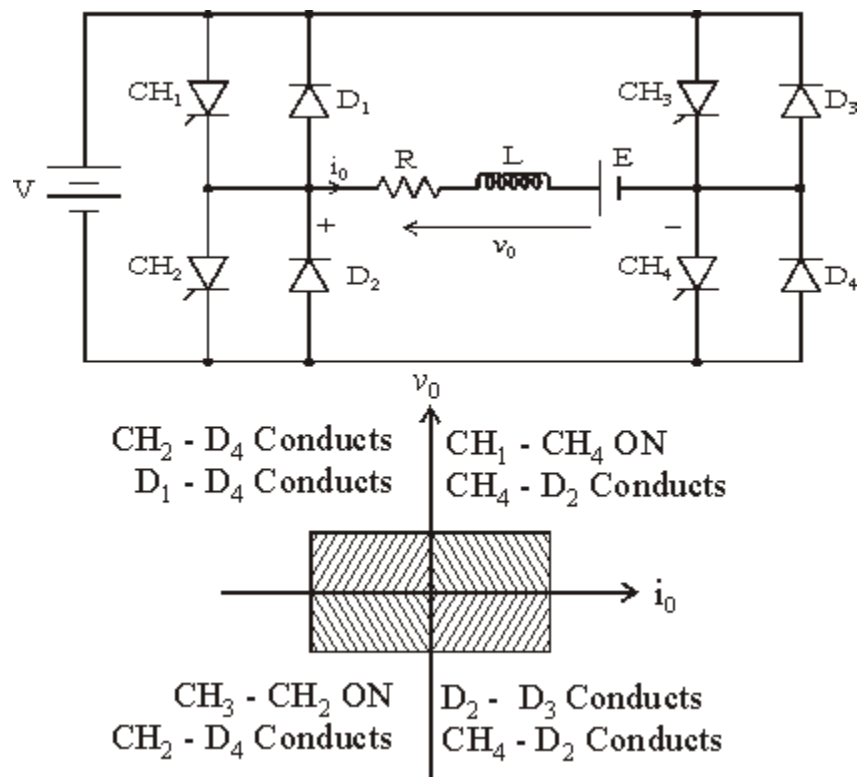

Figure: 3.18 circuit diagram and quadrant operation of Type E chopper

Numerical problems

1. A step up chopper has an input voltage of 150V. The voltage output needed is 450V. Given, that the thyristor has a conducting time of 150μseconds. Calculate the chopping frequency.

Solution –

The chopping frequency (f)

$$f = \frac{1}{T}$$

Where T - Chopping time period = $T_{ON} + T_{OFF}$

Given – $V_S = 150V$ $V_0 = 450V$ $T_{ON} = 150\mu sec$

$$V_0 = V_S \left(\frac{T}{T - T_{ON}} \right)$$

$$450 = 150 \frac{T}{T - 150 \times 10^{-6}} \quad T = 225\mu sec$$

Therefore, $f = \frac{1}{225 \times 10^{-6}} = 4.44KHz$

The new voltage output, on condition that the operation is at constant frequency after the halving the pulse width.

Halving the pulse width gives –

$$T_{ON} = \frac{150 \times 10^{-6}}{2} = 75\mu sec$$

The frequency is constant thus,

$$f = 4.44KHz$$

$$T = \frac{1}{f} = 150\mu sec$$

The voltage output is given by –

$$V_0 = V_S \left(\frac{T}{T - T_{ON}} \right) = 150 \times \left(\frac{150 \times 10^{-6}}{(150 - 75) \times 10^{-6}} \right) = 300V$$

2. In a type A chopper, the input supply voltage is 230 V the load resistance is 10Ω and there is a voltage drop of 2 V across the chopper thyristor when it is on. For a duty ratio of 0.4, calculate the average and rms values of the output voltage. Also find the chopper efficiency
3. A step-up chopper supplies a load of 480 V from 230 V dc supply. Assuming the non conduction period of the thyristor to be 50 microsecond, find the on time of the thyristor

Buck regulator

With power being a key parameter in many designs, step down or "buck" regulators are widely used.

Although a resistor would enable voltage to be dropped, power is lost, and in applications such as the many battery powered items used today, power consumption is a crucial element.

As a result step down switch mode converters or as they are more commonly termed, buck regulators are widely used.

Linear step down

The most basic form of step down transition is to use a resistor as a potential divider or voltage dropper. In some cases a zener diode may also be used to stabilize the voltage.

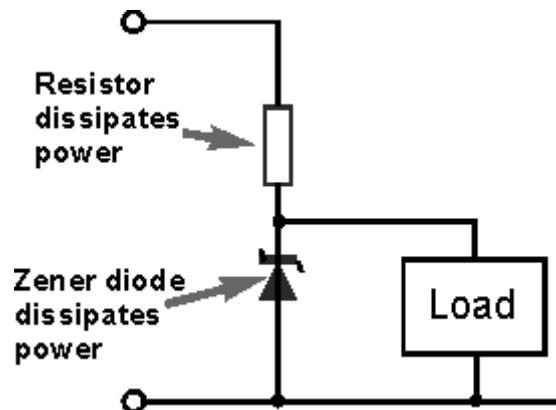

Figure: 3.19 Potential divider circuits

The issue with this form of voltage dropper or step down converter is that it is very wasteful in terms of power. Any voltage dropped across the resistor will be dissipated as heat, and any current flowing through the zener diode will also dissipate heat. Both of these elements result on the loss of valuable energy.

Basic buck converter or regulator

The fundamental circuit for a step down converter or buck converter consists of an inductor, diode, capacitor, switch and error amplifier with switch control circuitry.

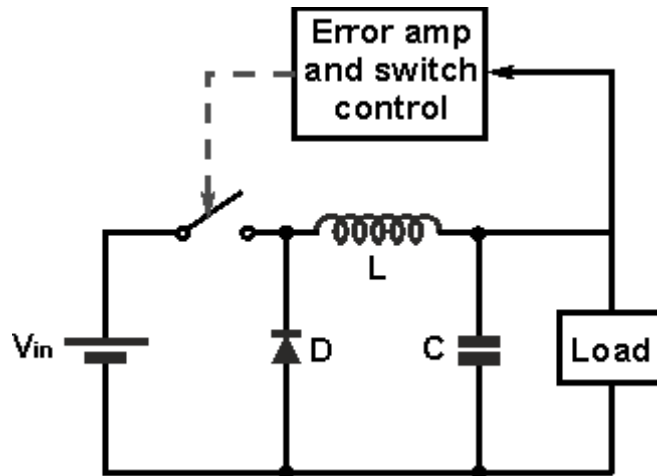

Figure: 3.20 circuit diagram of Buck regulator

The circuit for the buck regulator operates by varying the amount of time in which inductor receives energy from the source.

In the basic block diagram the operation of the buck converter or buck regulator can be seen that the output voltage appearing across the load is sensed by the sense / error amplifier and an error voltage is generated that controls the switch.

Typically the switch is controlled by a pulse width modulator, the switch remaining on of longer as more current is drawn by the load and the voltage tends to drop and often there is a fixed frequency oscillator to drive the switching.

Buck converter operation

When the switch in the buck regulator is on, the voltage that appears across the inductor is $V_{in} - V_{out}$. Using the inductor equations, the current in the inductor will rise at a rate of $(V_{in} - V_{out})/L$. At this time the diode D is reverse biased and does not conduct.

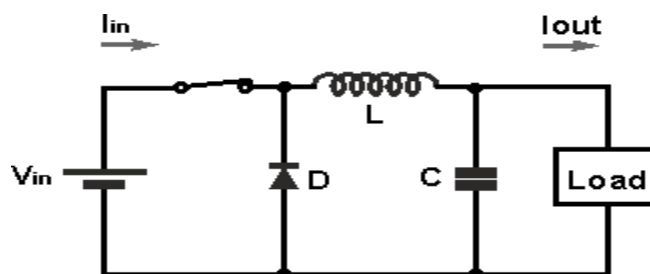

Figure: 3.21 circuit diagram of Buck regulator during switch on condition

When the switch opens, current must still flow as the inductor works to keep the same current flowing. As a result current still flows through the inductor and into the load. The diode, D then forms the return path with a current I_{diode} equal to I_{out} flowing through it.

With the switch open, the polarity of the voltage across the inductor has reversed and therefore the current through the inductor decreases with a slope equal to $-V_{out}/L$.

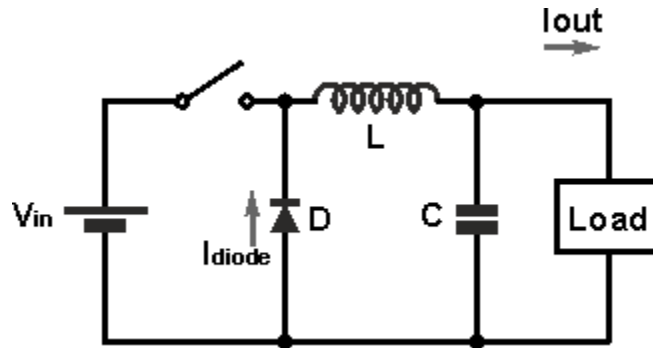

Figure: 3.22 circuit diagram of Buck regulator during switch off condition

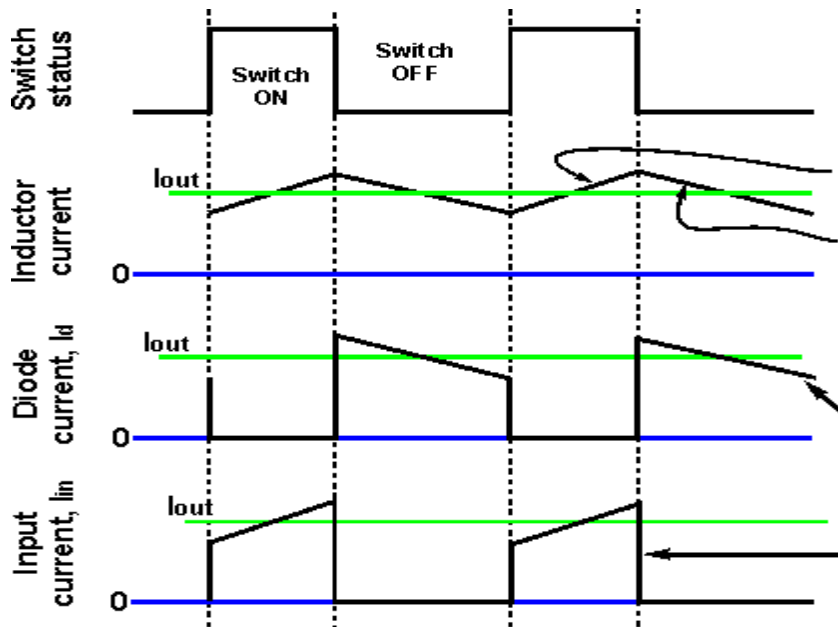

Figure: 3.23 Input and output waveforms of Buck regulator

In the diagram of the current waveforms for the buck converter / switching regulator, it can be seen that the inductor current is the sum of the diode and input / switch current. Current either flows through the switch or the diode.

It is also worth noting that the average input current is less than the average output current. This is to be expected because the buck converter circuit is very efficient and the input voltage is greater than the output voltage. Assuming a perfect circuit, then power in would equal power out, i.e. $V_{in} \cdot I_{in} = V_{out} \cdot I_{out}$. While in a real circuit there will be some losses, efficiency levels greater than 85% are to be expected for a well-designed circuit.

It will also be seen that there is a smoothing capacitor placed on the output. This serves to ensure that the voltage does not vary appreciably, especially during and switch transition times. It will also be required to smooth any switching spikes that occur.

Boost regulator

One of the advantages of switch mode power supply technology is that it can be used to create a step up or boost converter / regulator.

Boost converters or regulators are used in many instances from providing small supplies where higher voltages may be needed to much higher power requirements.

Often there are requirements for voltages higher than those provided by the available power supply - voltages for RF power amplifiers within mobile phones is just one example.

Step-up boost converter basics

The boost converter circuit has many similarities to the buck converter. However the circuit topology for the boost converter is slightly different. The fundamental circuit for a boost converter or step up converter consists of an inductor, diode, capacitor, switch and error amplifier with switch control circuitry.

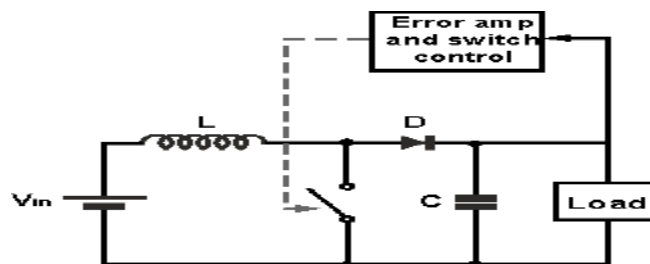

Figure: 3.24 circuit diagram of Boost regulator

The circuit for the step-up boost converter operates by varying the amount of time in which inductor receives energy from the source.

In the basic block diagram the operation of the boost converter can be seen that the output voltage appearing across the load is sensed by the sense / error amplifier and an error voltage is generated that controls the switch.

Typically the boost converter switch is controlled by a pulse width modulator, the switch remaining on of longer as more current is drawn by the load and the voltage tends to drop and often there is a fixed frequency oscillator to drive the switching.

Boost converter operation

The operation of the boost converter is relatively straightforward.

When the switch is in the ON position, the inductor output is connected to ground and the voltage V_{in} is placed across it. The inductor current increases at a rate equal to V_{in}/L .

When the switch is placed in the OFF position, the voltage across the inductor changes and is equal to $V_{out}-V_{in}$. Current that was flowing in the inductor decays at a rate equal to $(V_{out}-V_{in})/L$.

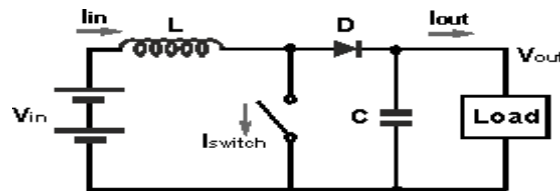

Figure: 3.25 circuit diagram of Boost regulator during switch off condition

Referring to the boost converter circuit diagram, the current waveforms for the different areas of the circuit can be seen as below.

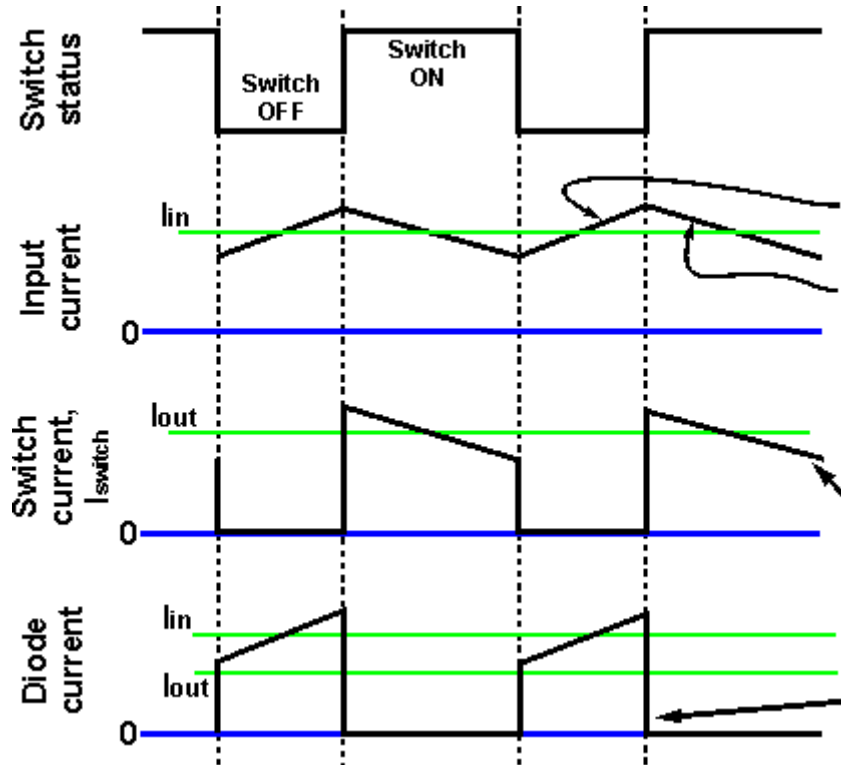

Figure: 3.26 Input and output waveforms of Boost regulator

It can be seen from the waveform diagrams that the input current to the boost converter is higher than the output current. Assuming a perfectly efficient, i.e. lossless, boost converter, the power out must equal the power in, i.e. $V_{in} \cdot I_{in} = V_{out} \cdot I_{out}$. From this it can be seen if the output voltage is higher than the input voltage, then the input current must be higher than the output current.

In reality no boost converter will be lossless, but efficiency levels of around 85% and more are achievable in most supplies.

Buck boost regulator

A simple buck converter can only produce voltages lower than the input voltage, and a boost converter, only voltages higher than the input. To provide voltages over the complete range a circuit known as a buck-boost converter is required.

There are many applications where voltages higher and lower than the input are required. In these situations a buck-boost converter is required.

Buck-Boost Converter basics

The buck-boost DC-DC converter offers a greater level of capability than the buck converter or boost converter individually, it as expected it extra components may be required to provide the level of functionality needed.

There are several formats that can be used for buck-boost converters:

- **+ V_{in} , - V_{out} :** This configuration of a buck-boost converter circuit uses the same number of components as the simple buck or boost converters. However this buck-boost regulator or DC-DC converter produces a negative output for a positive input. While this may be required or can be accommodated for a limited number of applications, it is not normally the most convenient format.

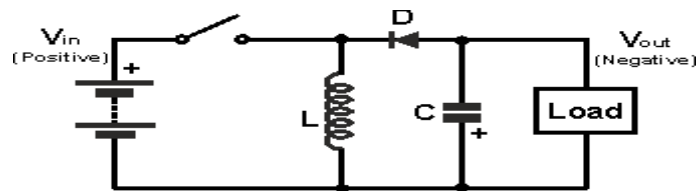

Figure: 3.27 circuit diagram of buck boost regulator

- When the switch is closed, current builds up through the inductor. When the switch is opened the inductor supplies current through the diode to the load.

Obviously the polarities (including the diode) within the buck-boost converter can be reversed to provide a positive output voltage from a negative input voltage.

- **+ V_{in} , + V_{out} :** The second buck-boost converter circuit allows both input and output to be the same polarity. However to achieve this, more components are required. The circuit for this buck boost converter is shown below.

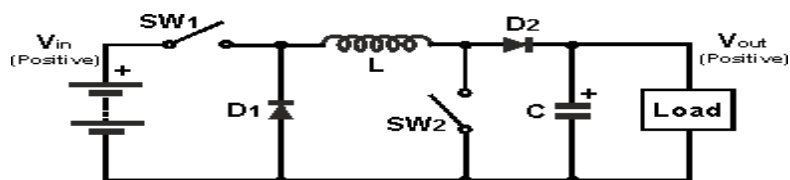

Figure: 3.28 circuit diagram of buck boost regulator with two switches

In this circuit, both switches act together, i.e. both are closed or open. When the switches are open, the inductor current builds. At a suitable point, the switches are opened. The inductor then supplies current to the load through a path incorporating both diodes, D1 and D2.

Numerical problems

1. In a dc chopper, the average load current is 30 Amps, chopping frequency is 250 Hz. Supply voltage is 110 volts. Calculate the ON and OFF periods of the chopper if the load resistance is 2 ohms.

Solution:

$$I_{dc} = 30 \text{ Amps, } f = 250 \text{ Hz, } V = 110 \text{ V, } R = 2\Omega$$

$$\text{Chopping period, } T = \frac{1}{f} = \frac{1}{250} = 4 \times 10^{-3} = 4 \text{ msec}$$

$$I_{dc} = \frac{V_{dc}}{R} \text{ and } V_{dc} = dV$$

$$\text{Therefore } I_{dc} = \frac{dV}{R}$$

$$d = \frac{I_{dc}R}{V} = \frac{30 \times 2}{110} = 0.545$$

$$\text{Chopper ON period, } t_{ON} = dT = 0.545 \times 4 \times 10^{-3} = 2.18 \text{ msec}$$

$$\text{Chopper OFF period, } t_{OFF} = T - t_{ON}$$

$$t_{OFF} = 4 \times 10^{-3} - 2.18 \times 10^{-3}$$

$$t_{OFF} = 1.82 \times 10^{-3} = 1.82 \text{ msec}$$

2. A step up chopper has input voltage of 220 V and output voltage of 660 V. If the non-conducting time of thyristor chopper is 100 micro sec compute the pulse width of output voltage. In case the pulse width is halved for constant frequency operation, find the new output voltage
3. A chopper operating from 220V dc supply with for a duty cycle of 0.5 and chopping frequency of 1KHz drives an R L load with $R = 1\Omega$, $L=1\text{mH}$ and $E = 105\text{V}$. Find whether the current is continuous and also find the values of I_{\max} and I_{\min} .

UNIT – V

INVERTERS

Introduction to Inverters

The word ‘inverter’ in the context of power-electronics denotes a class of power conversion (or power conditioning) circuits that operates from a dc voltage source or a dc current source and converts it into ac voltage or current. The inverter does reverse of what ac-to-dc converter does (refer to ac to dc converters). Even though input to an inverter circuit is a dc source, it is not uncommon to have this dc derived from an ac source such as utility ac supply. Thus, for example, the primary source of input power may be utility ac voltage supply that is converted to dc by an ac to dc converter and then ‘inverted’ back to ac using an inverter. Here, the final ac output may be of a different frequency and magnitude than the input ac of the utility supply

A single phase Half Bridge DC-AC inverter is shown in Figure below

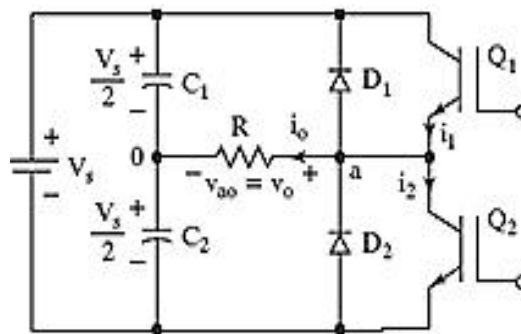

Figure: 5.1 Single phase Half Bridge DC-AC inverter with R load

The analysis of the DC-AC inverters is done taking into accounts the following assumptions and conventions.

- 1) The current entering node a is considered to be positive.
- 2) The switches S1 and S2 are unidirectional, i.e. they conduct current in one direction.
- 3) The current through S1 is denoted as i_1 and the current through S2 is i_2 .

The switching sequence is so design is shown in Figure below. Here, switch S1 is on for the time duration $0 \leq t \leq T_1$ and the switch S2 is on for the time duration $T_1 \leq t \leq T_2$. When switch S1 is turned on, the instantaneous voltage across the load is $v_o = V_{in}/2$

When the switch S2 is only turned on, the voltage across the load is

$$v_o = V_{in}/2.$$

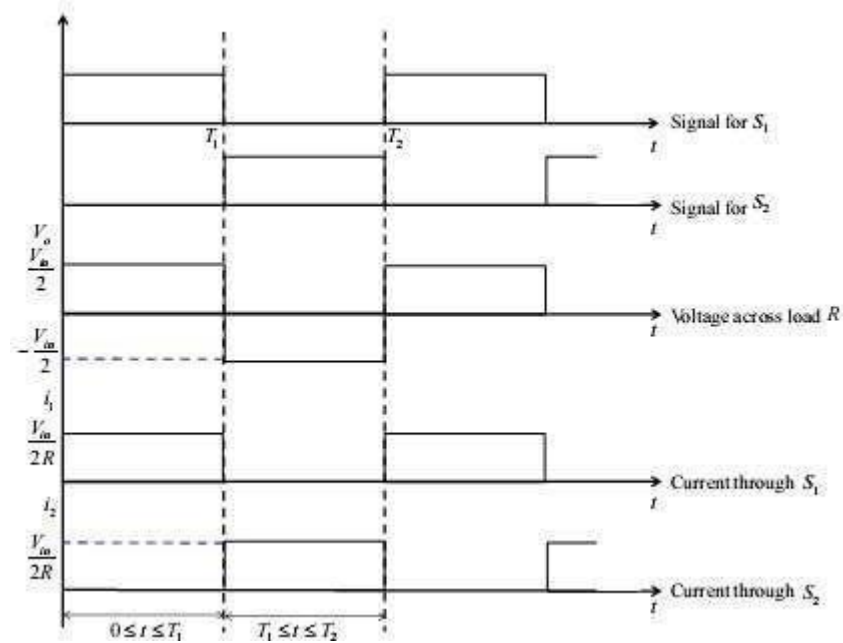

Figure: 5.2 Single phase Half Bridge DC-AC inverter output waveforms

The r.m.s value of output voltage v_o is given by,

$$V_{o,rms} = \left(\frac{1}{T_1} \int_0^{T_1} \frac{V_{in}^2}{4} dt \right) = \frac{V_{in}}{2}$$

The instantaneous output voltage v_o is rectangular in shape. The instantaneous value of v_o can be expressed in Fourier series as,

$$v_o = \frac{a_0}{2} + \sum_{n=1}^{\infty} a_n \cos(n\omega t) + b_n \sin(n\omega t)$$

Due to the quarter wave symmetry along the time axis, the values of a_0 and a_n are zero. The value of b_n is given by,

$$b_n = \frac{1}{\pi} \left[\int_{-\pi/2}^0 \frac{-V_{in}}{2} d(\omega t) + \int_0^{\pi/2} \frac{V_{in}}{2} d(\omega t) \right] = \frac{2V_{in}}{n\pi}$$

Substituting the value of b_n from above equation, we get

$$v_o = \sum_{n=1,3,5,\dots}^{\infty} \frac{2V_{in}}{n\pi} \sin(n\omega t)$$

The current through the resistor (i_L) is given by,

$$i_L = \sum_{n=1,3,5,\dots}^{\infty} \frac{1}{R} \frac{2V_{in}}{n\pi} \sin(n\omega t)$$

Half Bridge DC-AC Inverter with L Load and R-L Load

The DC-AC converter with inductive load is shown in Figure below. For an inductive load, the load current cannot change immediately with the output voltage.

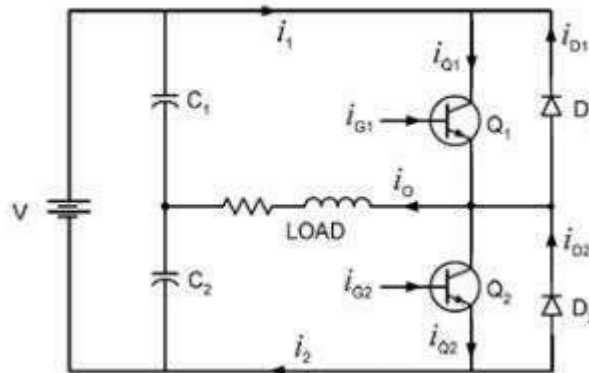

Figure: 5.3 Single phase Half Bridge DC-AC inverter with RL load

The working of the DC-AC inverter with inductive load is as follow is:

Case 1: In the time interval $0 < t < T_1$ the switch S_1 is on and the current flows through the inductor from points a to b. When the switch S_1 is turned off (case 1) at $t = T_1$, the load current would continue to flow through the capacitor C_2 and diode D_2 until the current falls to zero, as shown in Figure below.

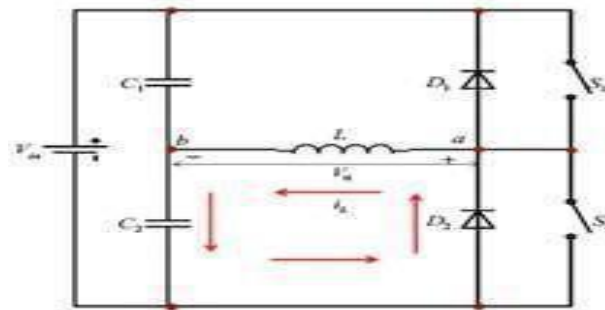

Figure: 5.4 Single phase Half Bridge DC-AC inverter with L load

Case 2: Similarly, when S2 is turned off at $t = T1$, the load current flows through the diode D1 and capacitor C1 until the current falls to zero, as shown in Figure below.

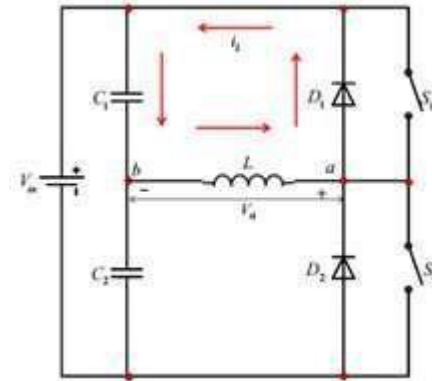

Figure: 5.5 Single phase Half Bridge DC-AC inverter with L load

When the diodes D1 and D2 conduct, energy is feedback to the dc source and these diodes are known as feedback diodes. These diodes are also known as freewheeling diodes. The current for purely inductive load is given by,

$$i_L = \sum_{n=1,3,5,\dots}^{\infty} \frac{1}{\omega n L} \frac{2V_{in}}{n\pi} \sin\left(n\omega t - \frac{\pi}{2}\right)$$

Similarly, for the R – L load. The instantaneous load current is obtained as,

$$i_L = \sum_{n=1,3,5,\dots}^{\infty} \frac{2V_{in}}{n\pi \sqrt{R^2 + (n\omega L)^2}} \sin(n\omega t - \theta_n)$$

Where,

$$\theta_n = \tan^{-1}\left(\frac{n\omega L}{R}\right)$$

Operation of single phase full bridge inverter

A single phase bridge DC-AC inverter is shown in Figure below. The analysis of the single phase DC-AC inverters is done taking into account following assumptions and conventions.

- 1) The current entering node a in Figure 8 is considered to be positive.
- 2) The switches S1, S2, S3 and S4 are unidirectional, i.e. they conduct current in one direction.

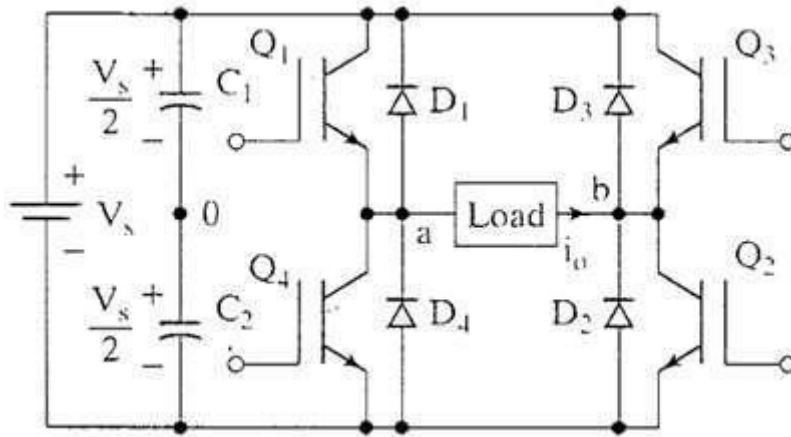

Figure: 5.6 Single phase Full Bridge DC-AC inverter with R load

When the switches S1 and S2 are turned on simultaneously for a duration $0 \leq t \leq T_1$, the the input voltage V_{in} appears across the load and the current flows from point a to b.

Q1 – Q2 ON, Q3 – Q4 OFF $\implies v_o = V_s$

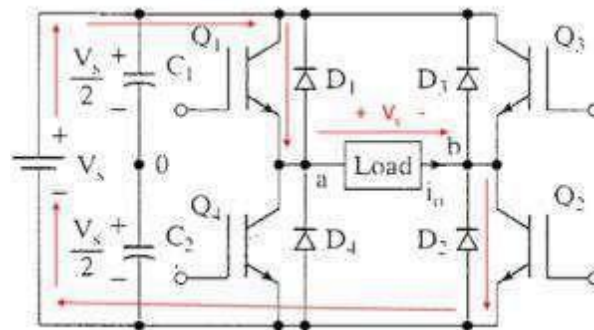

Figure: 5.7 Single phase Full Bridge DC-AC inverter with R load

If the switches S3 and S4 turned on duration $T_1 \leq t \leq T_2$, the voltage across the load the load is reversed and the current through the load flows from point b to a.

Q1 – Q2 OFF, Q3 – Q4 ON $\implies v_o = -V_s$

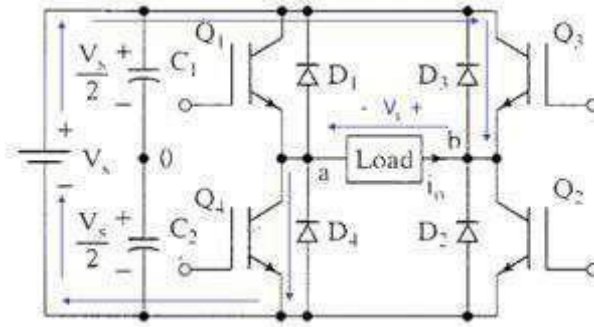

Figure: 5.8 Single phase Full Bridge DC-AC inverter with R load current directions

The voltage and current waveforms across the resistive load are shown in Figure below

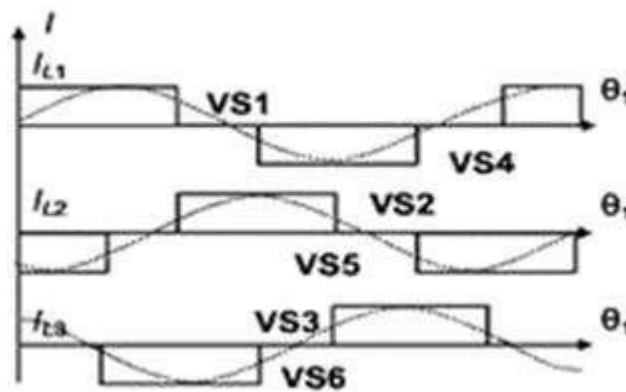

Figure: 5.9 Single phase Full Bridge DC-AC inverter waveforms

Single Phase Full Bridge Inverter for R-L load:

A single-phase square wave type voltage source inverter produces square shaped output voltage for a single-phase load. Such inverters have very simple control logic and the power switches need to operate at much lower frequencies compared to switches in some other types of inverters. The first generation inverters, using thyristor switches, were almost invariably square wave inverters because thyristor switches could be switched on and off only a few hundred times in a second. In contrast, the present day switches like IGBTs are much faster and used at switching frequencies of several kilohertz. Single-phase inverters mostly use half bridge or full bridge topologies. Power circuits of these topologies are shown in in Figure below.

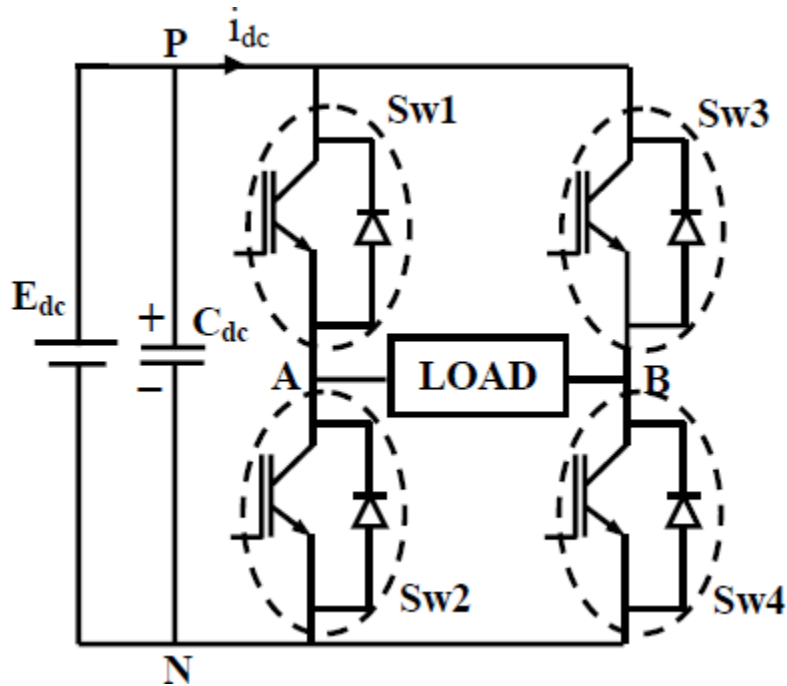

Figure: 5.10 Single phase Full Bridge DC-AC inverter with L load

The above topology is analyzed under the assumption of ideal circuit conditions. Accordingly, it is assumed that the input dc voltage (E_{dc}) is constant and the switches are lossless. In full bridge topology has two such legs. Each leg of the inverter consists of two series connected electronic switches shown within dotted lines in the figures. Each of these switches consists of an IGBT type controlled switch across which an uncontrolled diode is put in anti-parallel manner. These switches are capable of conducting bi-directional current but they need to block only one polarity of voltage. The junction point of the switches in each leg of the inverter serves as one output point for the load.

Series inverter:

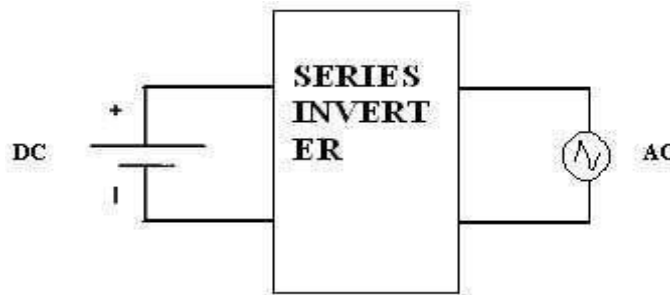

Figure: 5.11 Block diagram of series inverter

In **series inverter**, the commutating elements L and C are connected in series with the load. This constitutes a series RLC resonant circuit. The Two **SCRs** are used to produce the halves (positive and negative half cycle) in the output.

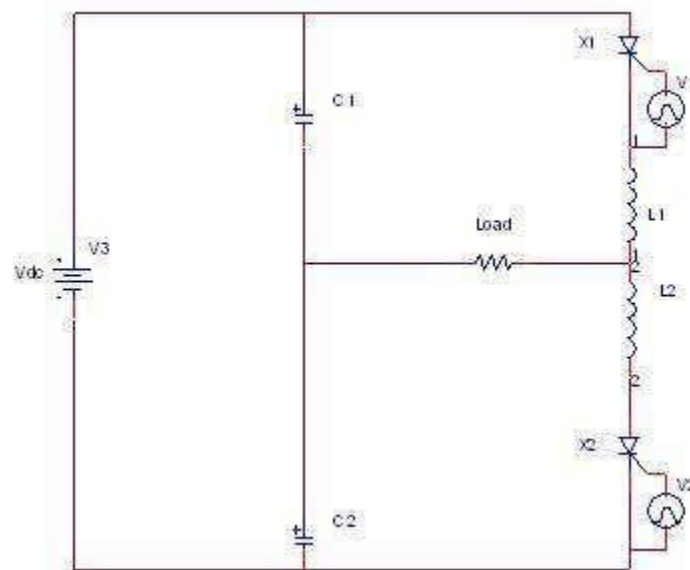

Figure: 5.12 Circuit diagram of series inverter

In the first half of the output currents when **SCR T1** is triggered it will allow the current to flow through L1, and load, and C2 thus charging. The capacitor C1 which is already charged at these instant discharges through **SCR1**, L1 and the Load. Hence 50% of the current is drawn from the input source and 50% from the capacitor. Similarly in the second half of the output current C1 will be charged and C2 will discharge through the load, L2 and **SCR2**, Again 50% of the load current is obtained from the DC input source and rest from the capacitor. The **SCRs** T1 and T2 are alternatively fired to get AC voltage and current.

Operation of parallel inverter

The **single phase parallel inverter circuit** consists of two **SCRs** T1 and T2, an inductor L, an output transformer and a commutating capacitor C. The output voltage and current are V_o and I_o respectively. The function of L is to make the source current constant. During the working of this

inverter, capacitor C comes in **parallel** with the load via the transformer. So it is called a **parallel inverter**.

The operation of this inverter can be explained in the following modes.

Mode I

In this mode, **SCR T1** is conducting and a current flow in the upper half of primary winding. **SCR T2** is OFF. As a result an emf V_s is induced across upper as well as lower half of the primary winding.

In other words total voltage across primary winding is $2V_s$. Now the capacitor C charges to a voltage of $2V_s$ with upper plate as positive.

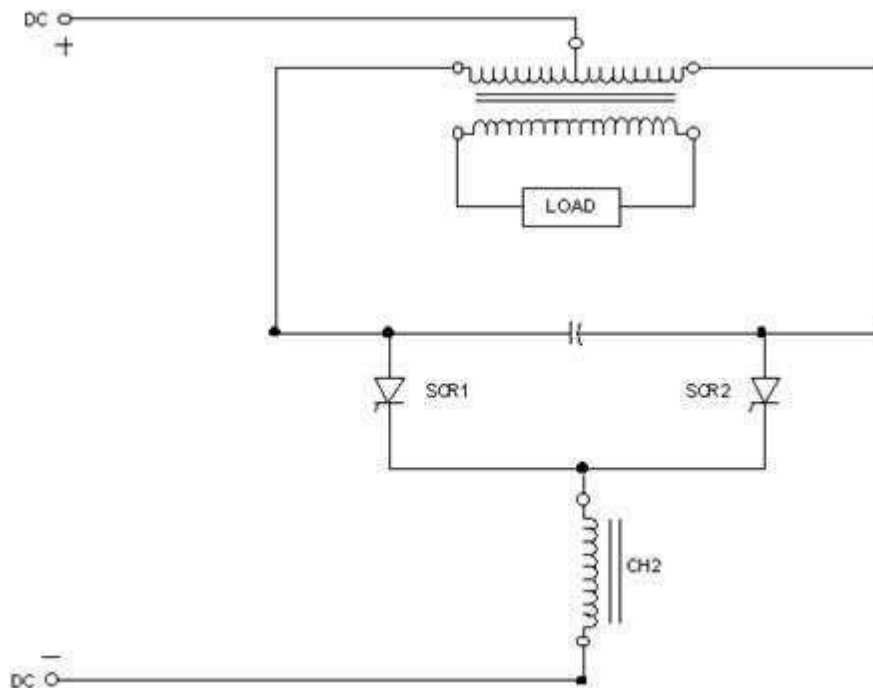

Figure: 5.13 Circuit diagram of parallel inverter

Mode II

At time t_0 , T2 is turned ON by applying a trigger pulse to its gate. At this time $t=0$, capacitor voltage $2V_s$ appears as a reverse bias across T1, it is therefore turned OFF. A current I_o begins to flow through T2 and lower half of primary winding. Now the capacitor has charged (upper plate as negative) from $+2V_s$ to $-2V_s$ at time $t=t_1$. Load voltage also changes from V_s at $t=0$ to $-V_s$ at $t=t_1$.

Mode III

When capacitor has charged to $-V_s$, T1 may be turned ON at any time. When T1 is triggered, capacitor voltage $2V_s$ applies a reverse bias across T2, it is therefore turned OFF. After T2 is OFF, capacitor starts discharging, and charged to the opposite direction, the upper plate as positive.

Paralleled Commutated Inverter

Fig 1: is a schematic of the classical **parallel** commutated square wave inverter bridge. It is being included here for illustrative purposes since most other circuits utilize this circuit or a variation thereof. The waveform generated and supplied to the load is basically a square wave having a peak to peak amplitude of twice the DC supply voltage and a period that is determined by the rate at which **SCRs** 1 through 4 are gated on. The **SCRs** are turned on in pairs by simultaneously applying signals to the gate terminals of **SCRs** 1 and 4 or **SCRs** 2 and 3. If **SCRs** 1 and 4 happen to be the first two switched on a current will flow from the positive terminal of the source through negative terminal of the source. This will establish a left to right, plus to minus voltage relationship on the load.

Simultaneously, the left terminal of capacitor C1 will be charged positively with respect to the right negative terminal. The steady-state load current through the various components is determined nearly completely by the impedance of the load. Chokes 1 and 2 and **SCRs** 1 and 4 present very low steady-state drops and therefore nearly all the source voltage appears across the load. Conduction of **SCRs** 1 and 4 will continue to the end of the half cycle, at which point the gates are removed from **SCRs** 1 and 4 remain in conduction along with **SCRs** 2 and 3 that have now been turned on. If it were not for chokes 1 and 2, the action of turning on the second set of **SCRs** would place very low impedance and therefore momentarily prevent the source from being short-circuited.

Capacitor C1 now discharges with a current which flows into the cathode of **SCR 1** through **SCR 2** in a forward direction back to the negative terminal of the capacitor. This direction of current flow causes **SCR 1** to become non-conductive provided that the reverse current through the **SCR** is of sufficient duration for the **SCR** to again become blocking. C1 simultaneously discharges through **SCR 3** in a forward direction and through **SCR 4** in a reverse direction. This will cause **SCR 4** to become non-conductive just the same **SCR 1**. This entire sequence is referred to as commutation and typically in a modern inverter would occur in a period of time less than 50 microseconds. During this interval, chokes 1 and 2 must have sufficient transient impedance to prevent a significant increase in current from the DC source.

Diodes 1, 2, 3 and 4 serve two functions. The first is to return any stored energy that may be "kicked back" from the load to the source. They also serve to prevent the choke from generating a high transient voltage immediately after commutation.

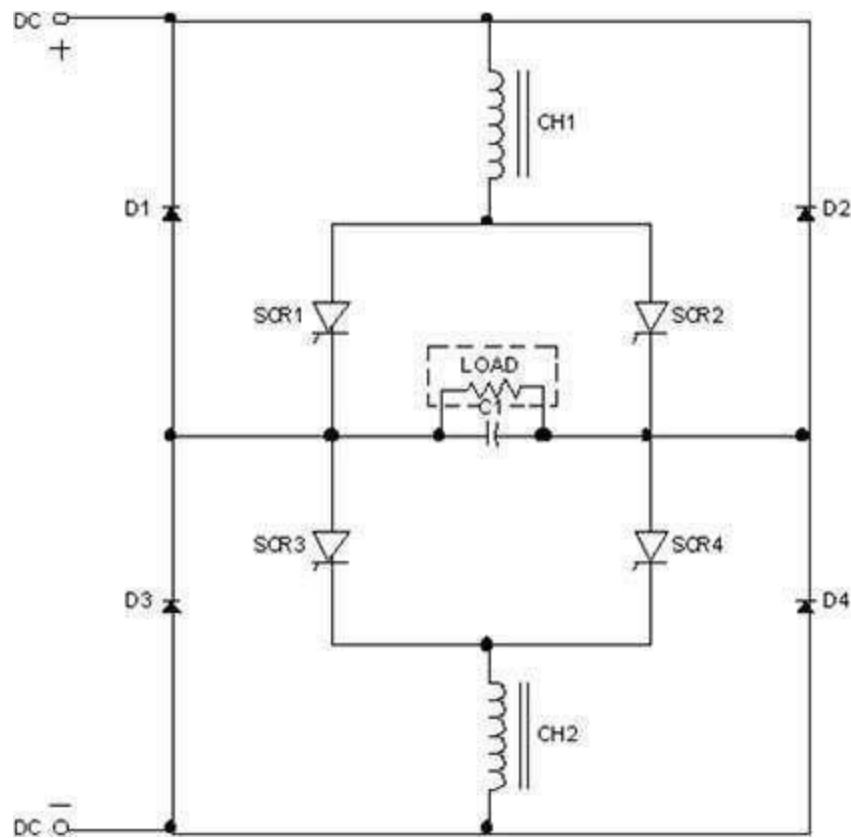

Figure: 5.14 Circuit diagram of parallel commutated inverter

Three Phase DC-AC Converters

Three phase inverters are normally used for high power applications. The advantages of a three phase inverter are:

- The frequency of the output voltage waveform depends on the switching rate of the switches and hence can be varied over a wide range.
- The direction of rotation of the motor can be reversed by changing the output phase sequence of the inverter.
- The ac output voltage can be controlled by varying the dc link voltage.

The general configuration of a three phase DC-AC inverter is shown in **Figure** Two types of control signals can be applied to the switches:

- 180° conduction
- 120° conduction

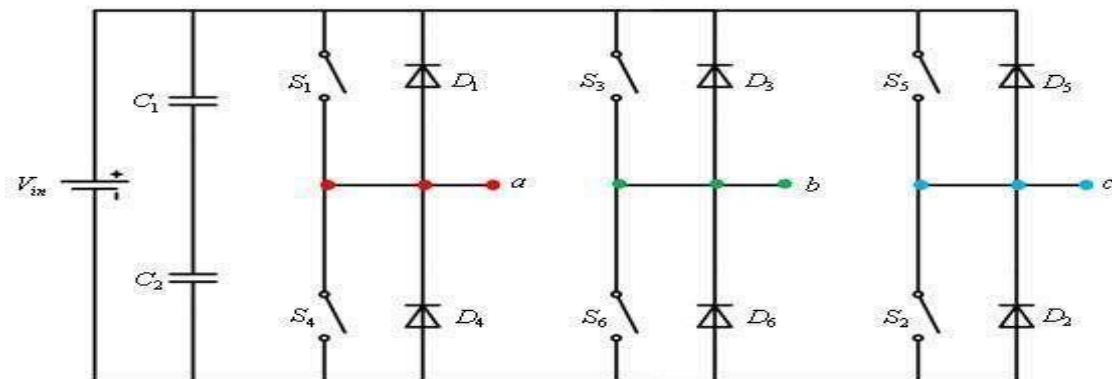

Figure: 5.15 Circuit diagram of three phase bridge inverter

180-Degree Conduction with Star Connected Resistive Load

The configuration of the three phase inverter with star connected resistive load is shown in **Figure**. The following convention is followed:

- A current leaving a node point a , b or c and entering the neutral point n is assumed to be positive.
- All the three resistances are equal, $R_a = R_b = R_c = R$.

In this mode of operation each switch conducts for 180° . Hence, at any instant of time **three switches** remain **on**. When S_1 is **on**, the terminal a gets connected to the positive terminal of input DC source. Similarly, when S_4 is **on**, terminal a gets connected to the negative terminal of input DC source. There are six possible modes of operation in a cycle and each mode is of 60° duration and the explanation of each mode is as follows:

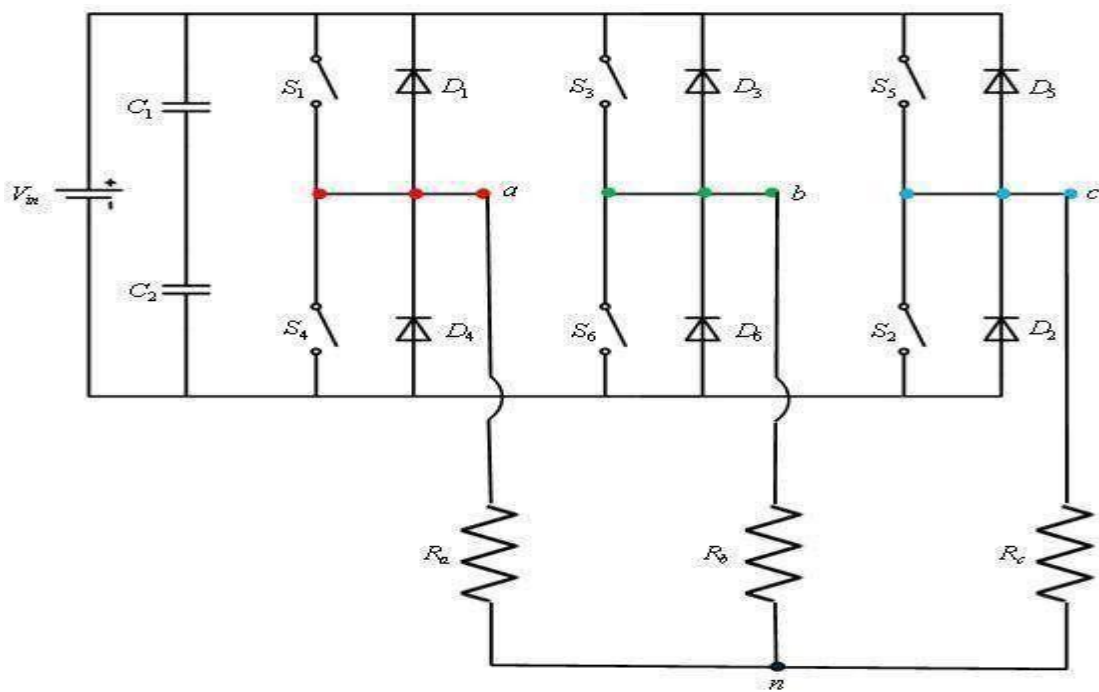

Figure: 5.16 Circuit diagram of three phase bridge inverter with star connected load

Mode 1 : In this mode the switches S_5 , S_6 and S_1 are turned **on** for time interval $0 \leq \omega t \leq \frac{\pi}{3}$. As a result of this the terminals a and c are connected to the positive terminal of the input DC source and the terminal b is connected to the negative terminal of the DC source. The current flow through R_a , R_b and R_c is shown in Figure and the equivalent circuit is shown in Figure. The equivalent resistance of the circuit shown in **Figure** is

$$R_{eq} = R + \frac{R}{2} = \frac{3R}{2} \quad (1)$$

The current i delivered by the DC input source is

$$i = \frac{V_{in}}{R_{eq}} = \frac{2 V_{in}}{3 R} \quad (2)$$

The currents i_a and i_b are

$$i_a = i_c = \frac{1 V_{in}}{3 R} \quad (3)$$

Keeping the current convention in mind, the current i_b is

$$i_b = -i = -\frac{2 V_{in}}{3 R} \quad (4)$$

Having determined the currents through each branch, the voltage across each branch is

$$v_{an} = v_{cn} = i_a R = \frac{V_m}{3}; \quad v_{bn} = i_b R = -\frac{2V_m}{3} \quad (5)$$

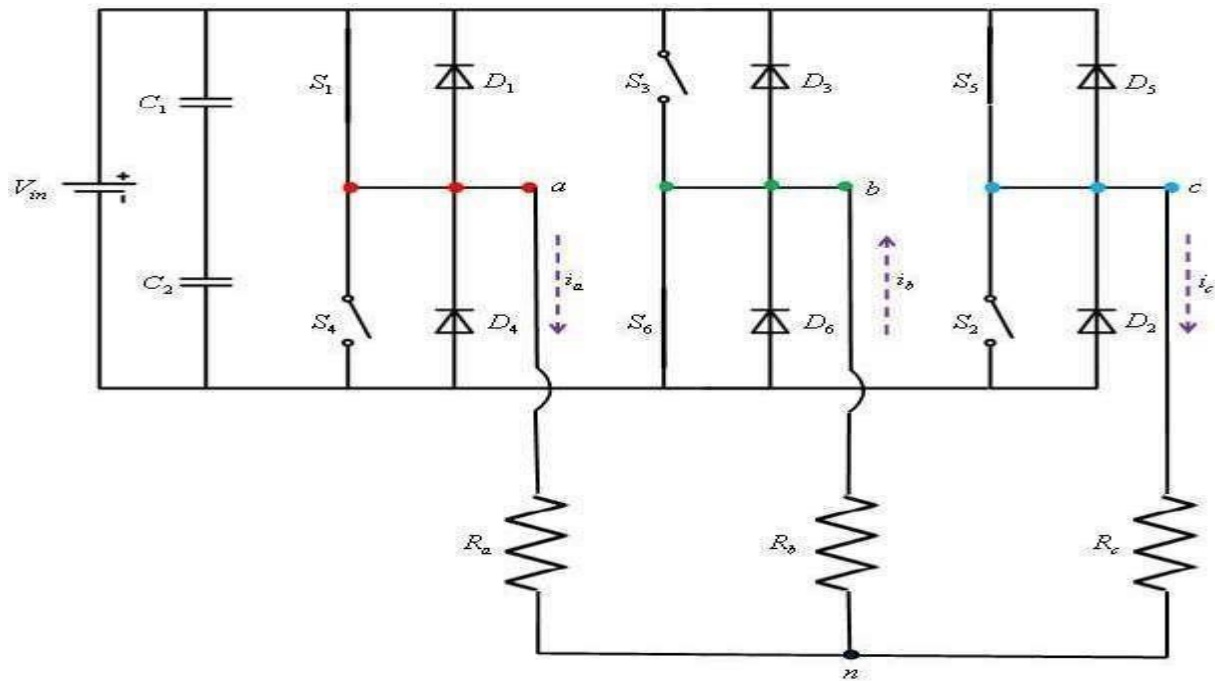

Figure: 5.17 Mode 1 operation of three phase bridge inverter with star connected load

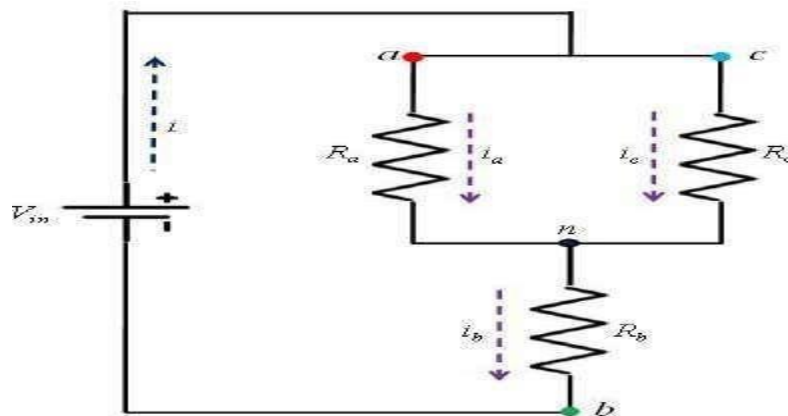

Figure: 5.18 Current flow in Mode 1 operation

Mode 2 : In this mode the switches S_6 , S_1 and S_2 are turned **on** for time interval $\frac{\pi}{3} \leq \omega t \leq \frac{2\pi}{3}$. The current flow and the equivalent circuits are shown in **Figure** and **Figure** respectively. Following the reasoning given for **mode 1**, the currents through each branch and the voltage drops are given by

$$i_b = i_c = \frac{1}{3} \frac{V_m}{R}; i_a = -\frac{2}{3} \frac{V_m}{R} \quad (6)$$

$$v_{bn} = v_{cn} = \frac{V_{in}}{3}; v_{an} = -\frac{2V_m}{3} \quad (7)$$

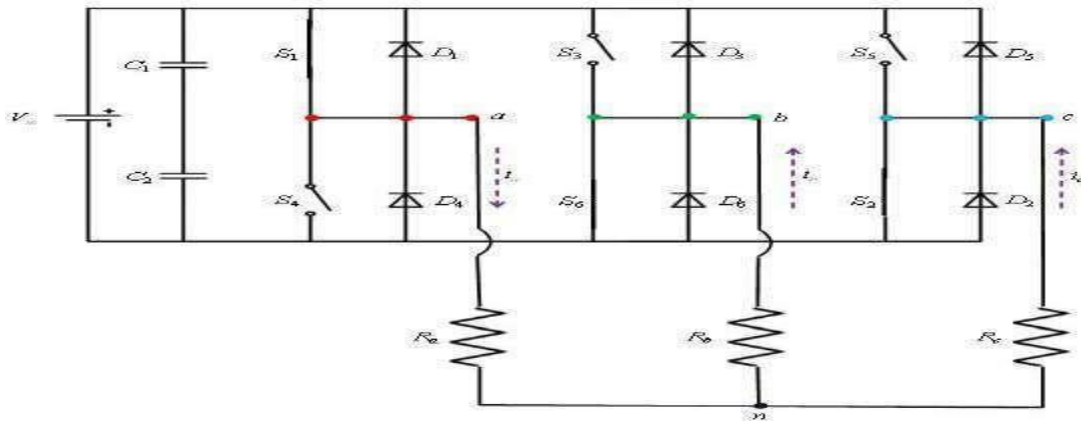

Figure: 5.19 Mode 2 operation of three phase bridge inverter with star connected load

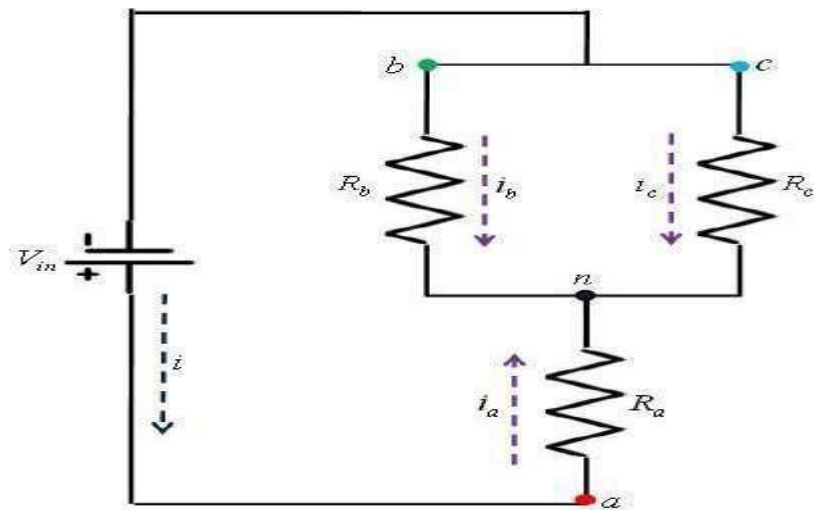

Figure: 5.20 Current flow in Mode 2 operation

Mode 3 : In this mode the switches S_1 , S_2 and S_3 are **on** for $\frac{2\pi}{3} \leq \omega t \leq \pi$. The current flow and the equivalent circuits are shown in **Figure** and **figure** respectively. The magnitudes of currents and voltages are:

$$i_a = i_b = \frac{1}{3} \frac{V_m}{R}; i_c = -\frac{2}{3} \frac{V_m}{R} \quad (8)$$

$$v_{an} = v_{bn} = \frac{V_m}{3}; v_{cn} = -\frac{2V_m}{3} \quad (9)$$

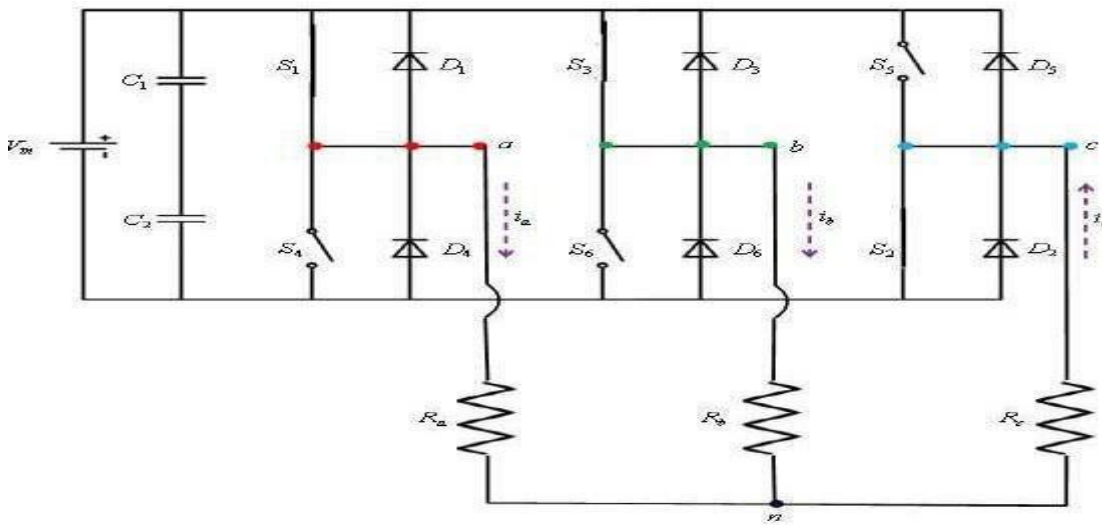

Figure: 5.21 Mode 3 operation of three phase bridge inverter with star connected load

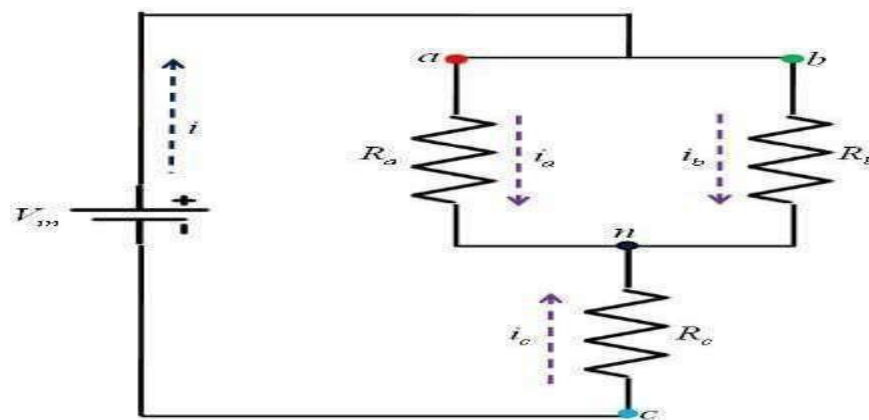

Figure: 5.23 Current flow in Mode 3 operation

For *modes 4, 5* and *6* the equivalent circuits will be same as *modes 1, 2* and *3* respectively. The voltages and currents for each mode are:

$$\left. \begin{aligned} i_a = i_c = -\frac{1}{3} \frac{V_{in}}{R}, i_b = \frac{2}{3} \frac{V_{in}}{R} \\ v_{an} = v_{cn} = -\frac{V_{in}}{3}, V_{bn} = \frac{2V_{in}}{3} \end{aligned} \right\} \text{for mode 4} \quad (10)$$

$$\left. \begin{aligned} i_b = i_c = -\frac{1}{3} \frac{V_{in}}{R}, i_a = \frac{2}{3} \frac{V_{in}}{R} \\ v_{bn} = v_{cn} = -\frac{V_{in}}{3}, V_{an} = \frac{2V_{in}}{3} \end{aligned} \right\} \text{for mode5} \quad (11)$$

$$\left. \begin{aligned} i_a = i_b = -\frac{1}{3} \frac{V_{in}}{R}, i_c = \frac{2}{3} \frac{V_{in}}{R} \\ v_{an} = v_{bn} = -\frac{V_{in}}{3}, V_{cn} = \frac{2V_{in}}{3} \end{aligned} \right\} \text{for mode 6} \quad (12)$$

The plots of the phase voltages (v_{an} , v_{bn} and v_{cn}) and the currents (i_a , i_b and i_c) are shown in **Figure**. Having known the phase voltages, the line voltages can also be determined as:

$$\begin{aligned} v_{ab} &= v_{an} - v_{bn} \\ v_{bc} &= v_{bn} - v_{cn} \\ v_{ca} &= v_{cn} - v_{an} \end{aligned} \quad (13)$$

The plots of line voltages are also shown in **Figure** and the phase and line voltages can be expressed in terms of Fourier series as:

$$\begin{aligned}
v_{an} &= \sum_{n=1,3,5,\dots}^{\infty} \frac{4V_m}{3n\pi} \left[1 + \sin \frac{n\pi}{2} \sin \frac{n\pi}{6} \right] \sin(n\omega t) \\
v_{bn} &= \sum_{n=1,3,5,\dots}^{\infty} \frac{4V_m}{3n\pi} \left[1 + \sin \frac{n\pi}{2} \sin \frac{n\pi}{6} \right] \sin\left(n\omega t - \frac{2n\pi}{3}\right) \\
v_{cn} &= \sum_{n=1,3,5,\dots}^{\infty} \frac{4V_m}{3n\pi} \left[1 + \sin \frac{n\pi}{2} \sin \frac{n\pi}{6} \right] \sin\left(n\omega t - \frac{4n\pi}{3}\right)
\end{aligned} \tag{14}$$

$$\begin{aligned}
v_{ab} = v_{an} - v_{bn} &= \sum_{n=1,3,5,\dots}^{\infty} \frac{4V_m}{n\pi} \sin \frac{n\pi}{2} \sin \frac{n\pi}{3} \sin\left(n\omega t + \frac{n\pi}{6}\right) \\
v_{bc} = v_{bn} - v_{cn} &= \sum_{n=1,3,5,\dots}^{\infty} \frac{4V_m}{n\pi} \sin \frac{n\pi}{2} \sin \frac{n\pi}{3} \sin\left(n\omega t - \frac{n\pi}{2}\right) \\
v_{ca} = v_{cn} - v_{an} &= \sum_{n=1,3,5,\dots}^{\infty} \frac{4V_m}{n\pi} \sin \frac{n\pi}{2} \sin \frac{n\pi}{3} \sin\left(n\omega t - \frac{7n\pi}{6}\right)
\end{aligned} \tag{15}$$

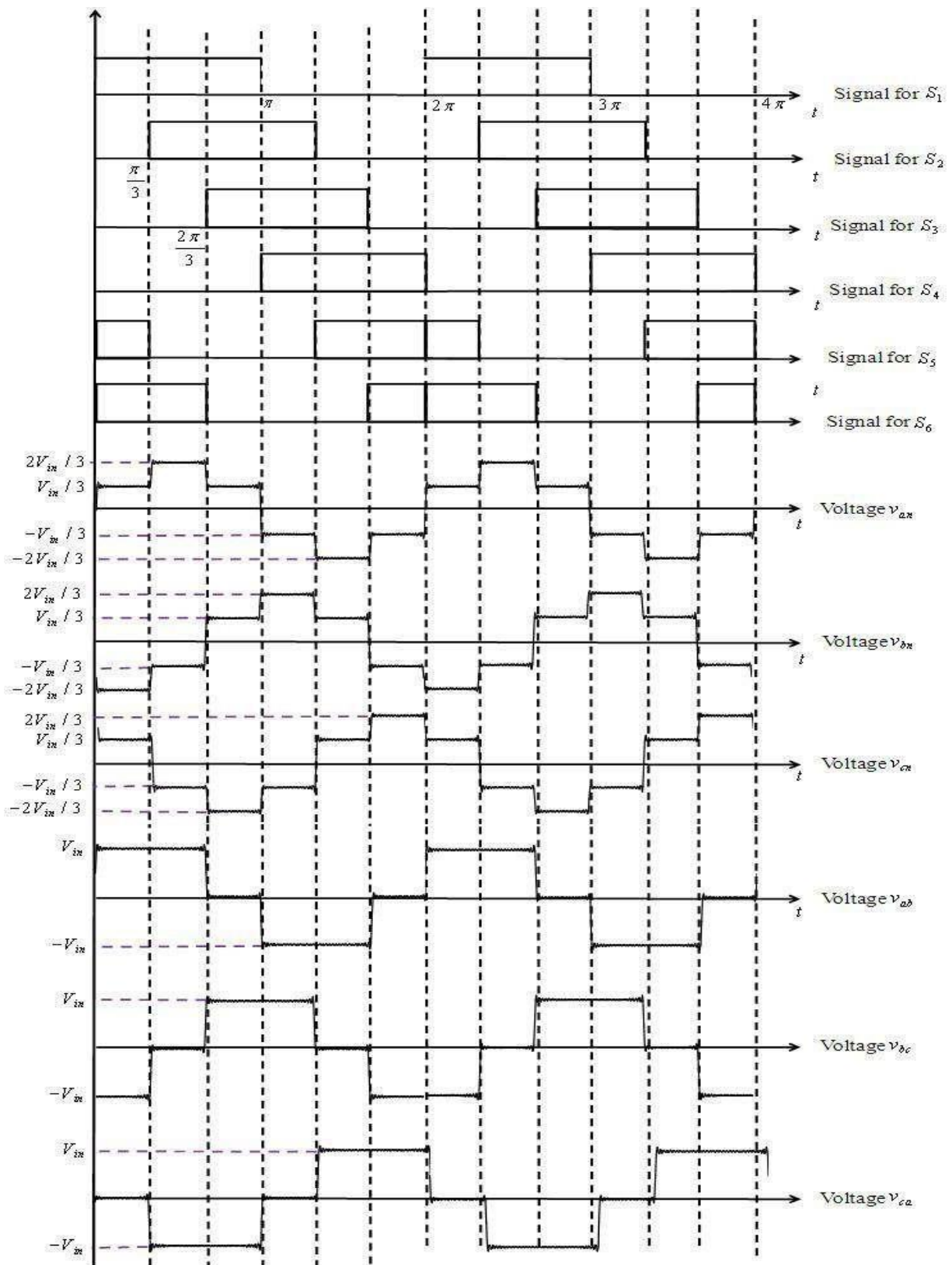

Figure: 5.24 Line and phase voltages of three phase bridge inverter

Three Phase DC-AC Converters with 120 degree conduction mode

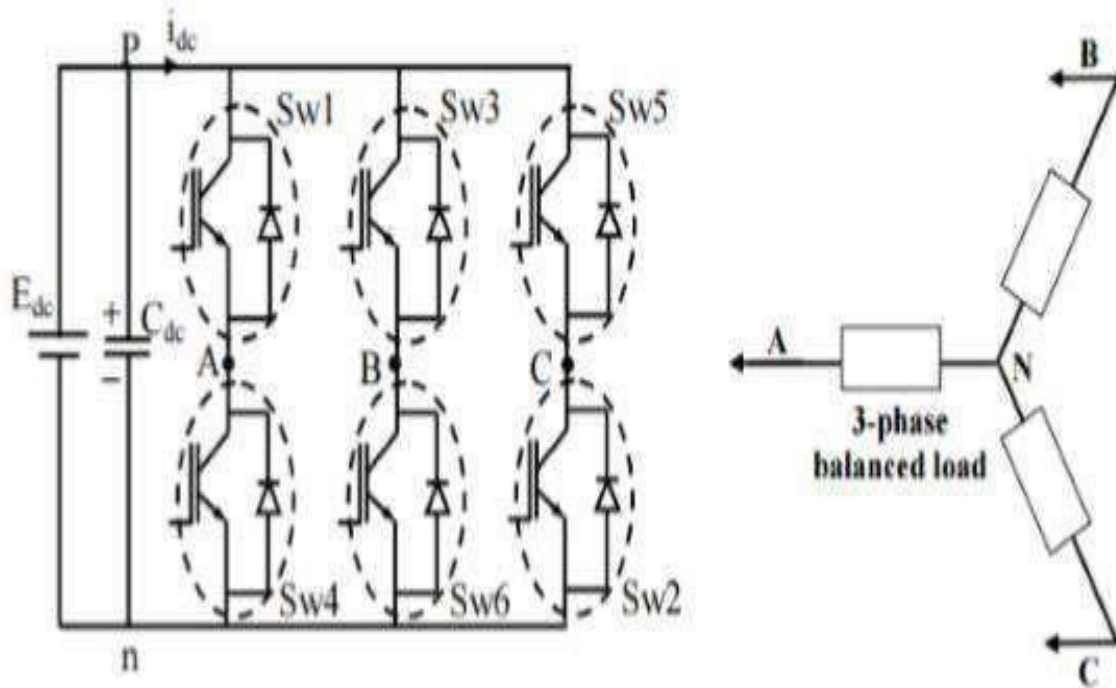

Figure: 5.25 Circuit diagram of three phase bridge inverter

120° mode of conduction

In this mode of conduction, each electronic device is in a conduction state for 120°. It is most suitable for a delta connection in a load because it results in a six-step type of waveform across any of its phases. Therefore, at any instant only two devices are conducting because each device conducts at only 120°.

The terminal A on the load is connected to the positive end while the terminal B is connected to the negative end of the source. The terminal C on the load is in a condition called floating state. Furthermore, the phase voltages are equal to the load voltages as shown below.

Phase voltages = Line voltages

$$V_{AB} = V$$

$$V_{BC} = -V/2$$

$$V_{CA} = -V/2$$

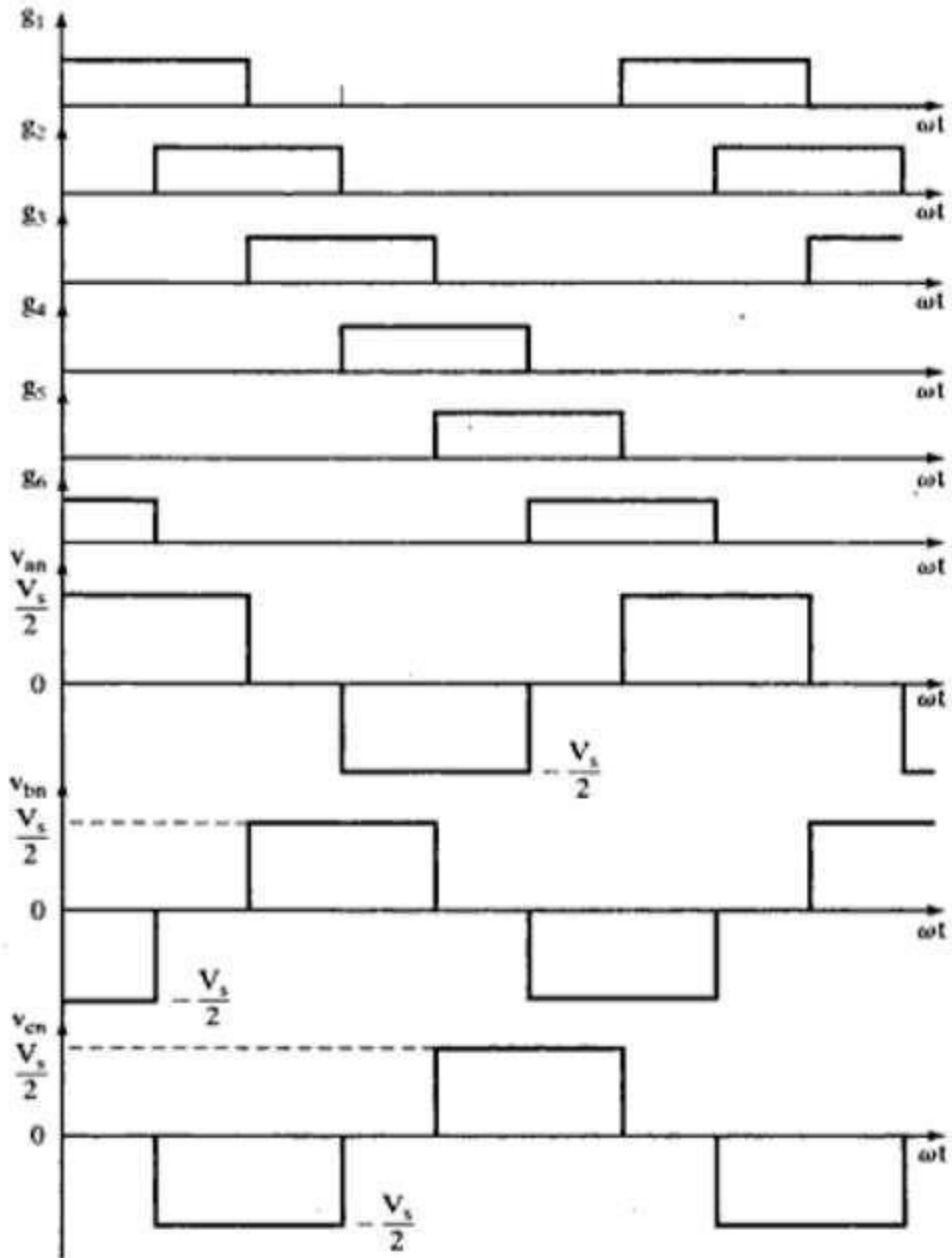

Figure: 5.26 Line and phase voltages of three phase bridge inverter

Voltage control techniques for inverters

Pulse width modulation techniques

PWM is a technique that is used to reduce the overall harmonic distortion (THD) in a load current. It uses a pulse wave in rectangular/square form that results in a variable average waveform value $f(t)$, after its pulse width has been modulated. The time period for modulation is given by T . Therefore, waveform average value is given by

$$y = \frac{1}{T} \int_0^T f(t) dt$$

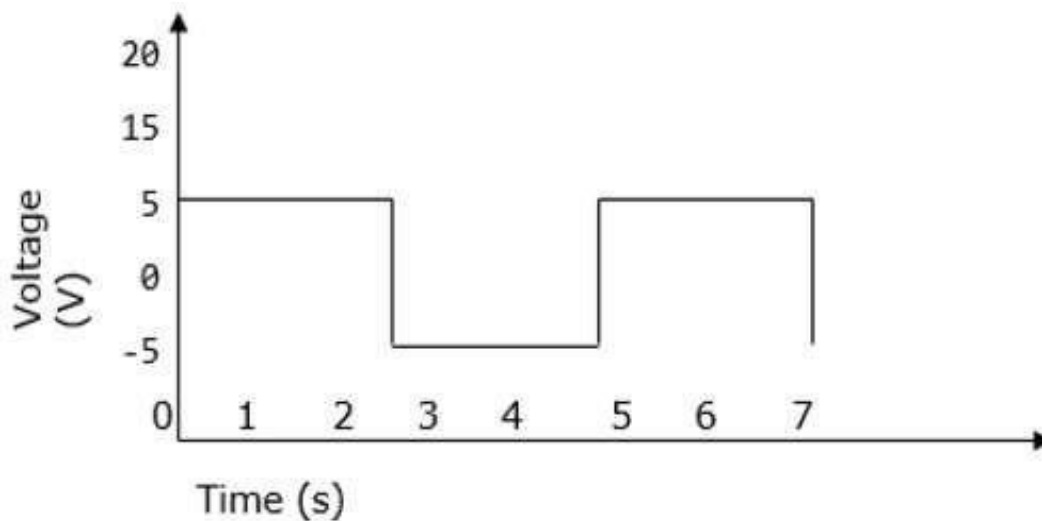

Figure: 5.27 Square waveform used for PWM technique

Sinusoidal Pulse Width Modulation

In a simple source voltage inverter, the switches can be turned ON and OFF as needed. During each cycle, the switch is turned on or off once. This results in a square waveform. However, if the switch is turned on for a number of times, a harmonic profile that is improved waveform is obtained.

The sinusoidal PWM waveform is obtained by comparing the desired modulated waveform with a triangular waveform of high frequency. Regardless of whether the voltage of the signal is smaller or larger than that of the carrier waveform, the resulting output voltage of the DC bus is either negative or positive.

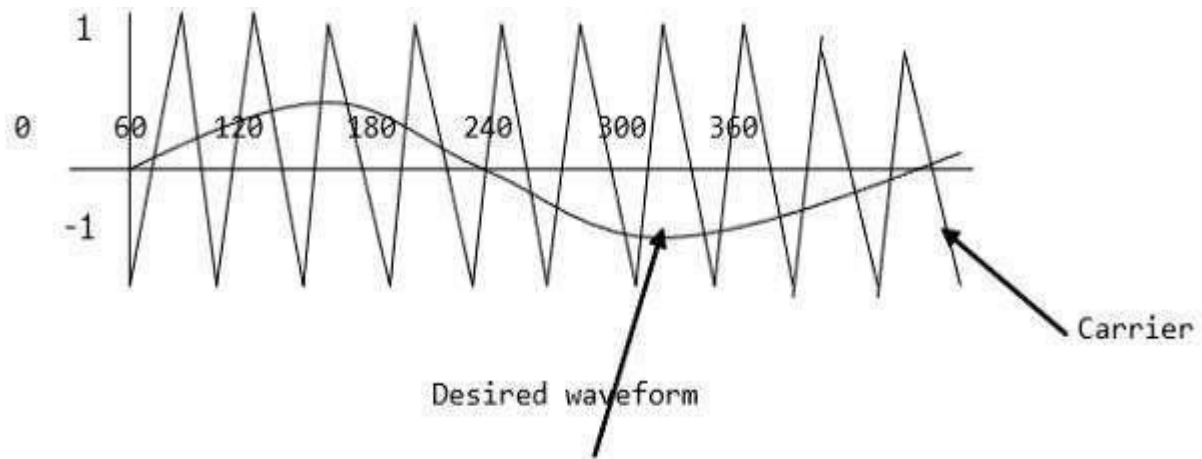

Figure: 5.28 Sinusoidal PWM waveform

The sinusoidal amplitude is given as A_m and that of the carrier triangle is given as A_c . For sinusoidal PWM, the modulating index m is given by A_m/A_c .

Modified Sinusoidal Waveform PWM

A modified sinusoidal PWM waveform is used for power control and optimization of the power factor. The main concept is to shift current delayed on the grid to the voltage grid by modifying the PWM converter. Consequently, there is an improvement in the efficiency of power as well as optimization in power factor.

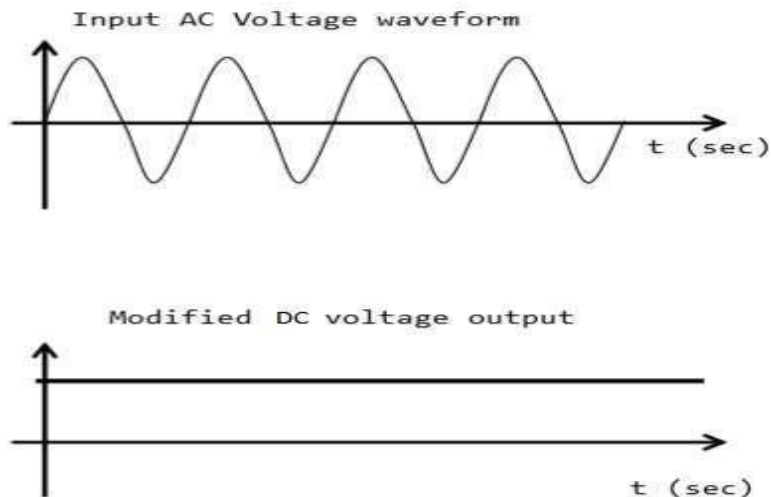

Figure: 5.29 Modified sinusoidal PWM waveform

Multiple PWM

The multiple PWM has numerous outputs that are not the same in value but the time period over which they are produced is constant for all outputs. Inverters with PWM are able to operate at high voltage output.

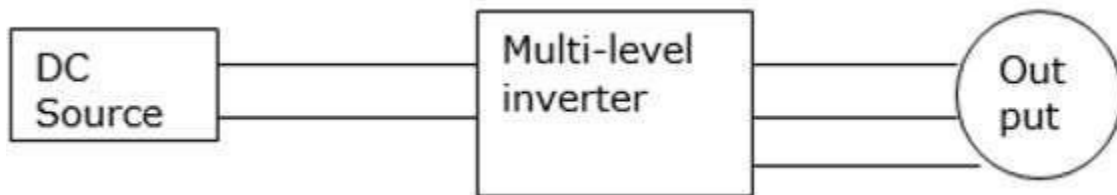

Figure: 5.30 Block diagram of multiple PWM technique

The waveform below is a sinusoidal wave produced by a multiple PWM

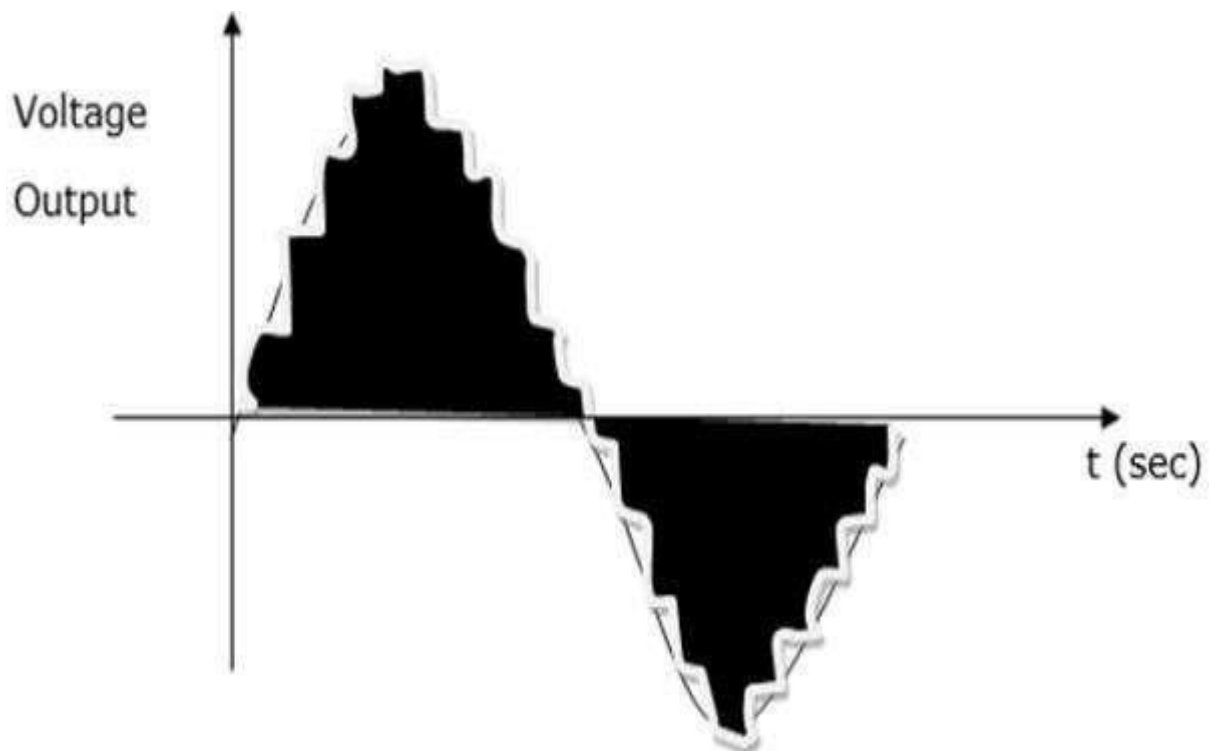

Figure: 5.31 Waveform of multiple PWM technique

Voltage and Harmonic Control

A periodic waveform that has frequency, which is a multiple integral of the fundamental power with frequency of 60Hz is known as a harmonic. Total harmonic distortion (THD) on the other hand refers to the total contribution of all the harmonic current frequencies.

Harmonics are characterized by the pulse that represents the number of rectifiers used in a given circuit. It is calculated as follows

$$h = (n \times P) + 1 \text{ or } -1$$

Where n – is an integer 1, 2, 3, 4, ...n

P – Number of rectifiers

Harmonics have an impact on the voltage and current output and can be reduced using isolation transformers, line reactors, redesign of power systems and harmonic filters.

Operation of sinusoidal pulse width modulation

The sinusoidal PWM (SPWM) method also known as the triangulation, sub harmonic, or sub oscillation method, is very popular in industrial applications. The SPWM is explained with reference to Figure, which is the half-bridge circuit topology for a single-phase inverter.

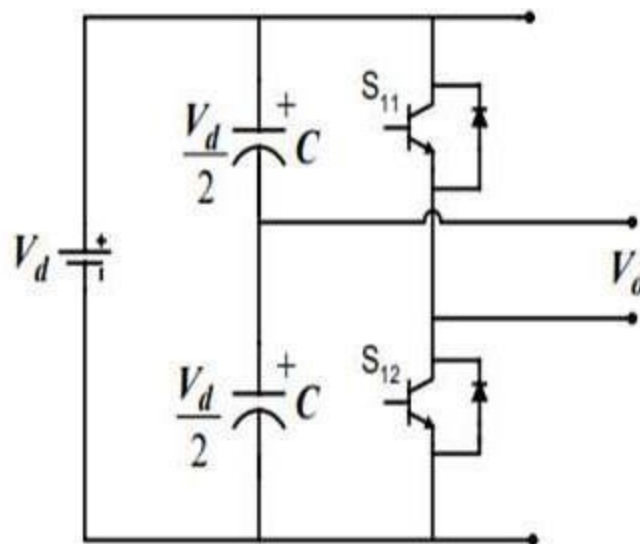

Figure: 5.32 schematic diagram of Half bridge PWM inverter

For realizing SPWM, a high-frequency triangular carrier wave is compared with a sinusoidal reference of the desired frequency. The intersection of and waves determines the switching instants and commutation of the modulated pulse. The PWM scheme is illustrated in Figure, in which v_c the peak value of triangular carrier wave and v_r is that of the reference, or modulating signal. The figure shows the triangle and modulation signal with some arbitrary frequency and magnitude. In the inverter of Figure the switches and are controlled based on the comparison of control signal and the triangular wave which are mixed in a comparator. When sinusoidal wave has magnitude higher than the triangular wave the comparator output is high, otherwise it is low.

$$v_r > v_c \quad S_{11} \text{ is on, } V_{out} = \frac{V_d}{2}$$

and

$$v_r < v_c \quad S_{12} \text{ is on, } V_{out} = -\frac{V_d}{2}$$

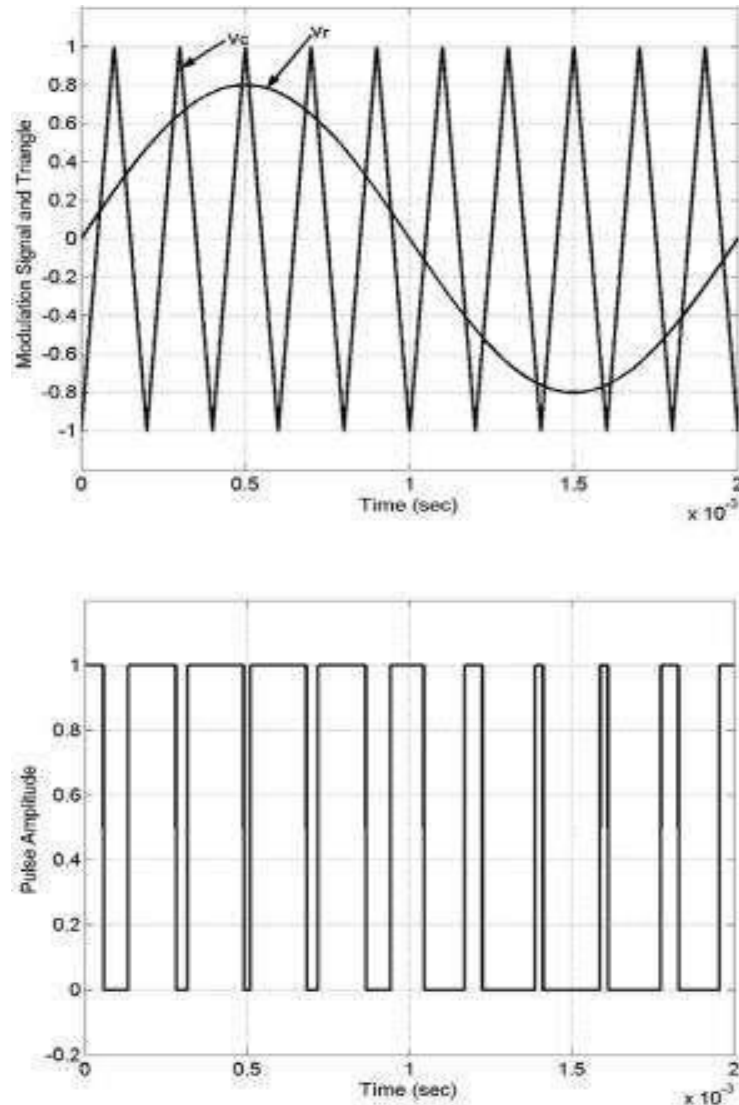

Figure: 5.33 Sine-Triangle Comparison and switching pulses of half bridge PWM inverter

The comparator output is processed in a trigger pulse generator in such a manner that the output voltage wave of the inverter has a pulse width in agreement with the comparator output pulse width. The magnitude ratio of V_i/V_c is called the modulation index (MI) and it controls the harmonic content of the output voltage waveform. The magnitude of fundamental component of output voltage is proportional to MI. The amplitude of the triangular wave is generally kept constant. The frequency modulation ratio is defined as

$$M_F = \frac{f_r}{f_m}$$

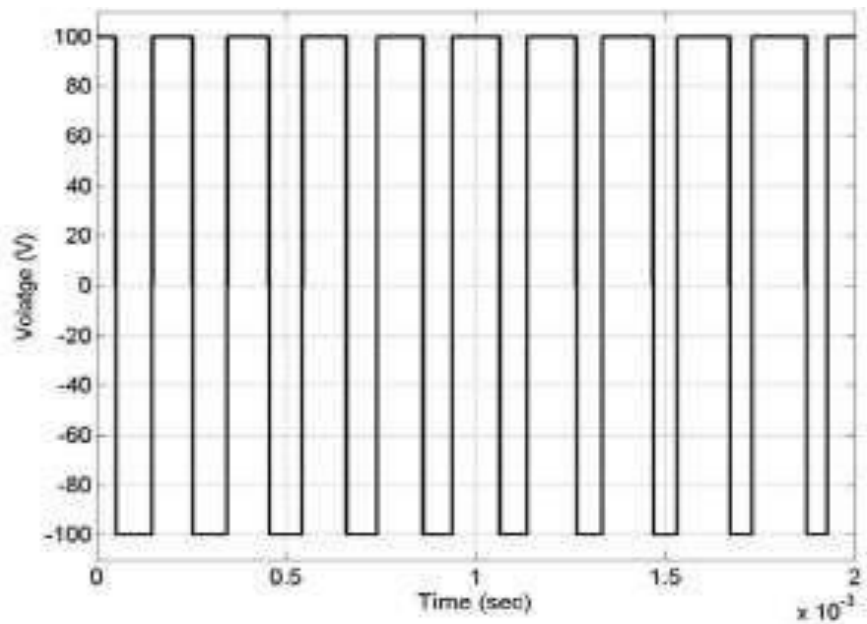

Figure: 5.34 Output voltage of the Half-Bridge inverter

Operation of current source inverter with ideal switches

Single-phase Current Source Inverter

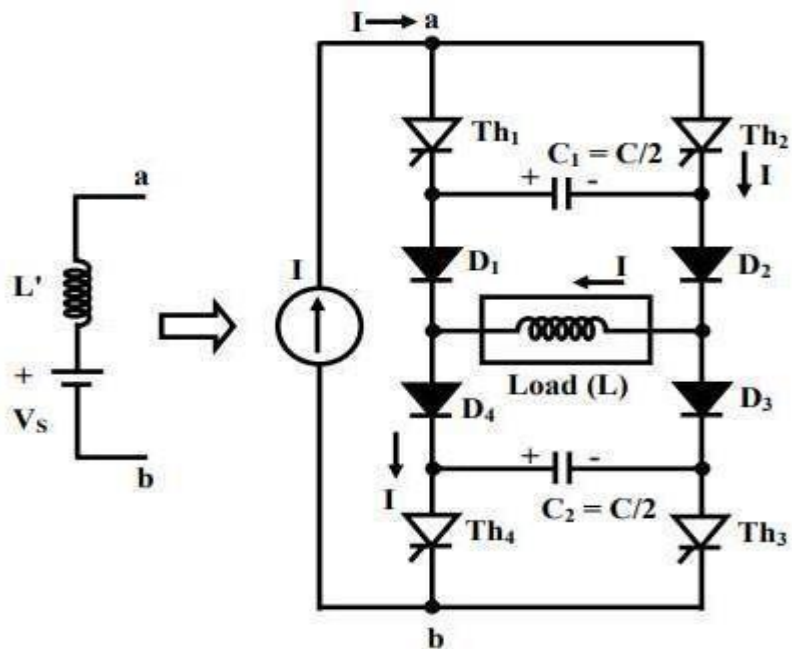

Figure: 5.35 Single phase current source inverter (CSI) of ASCII type

The circuit of a Single-phase Current Source Inverter (CSI) is shown in Fig. 5.35. The type of operation is termed as Auto-Sequential Commutated Inverter (ASCI). A constant current source is assumed here, which may be realized by using an inductance of suitable value, which must be high, in series with the current limited dc voltage source. The thyristor pairs, Th1 & Th3, and Th2 & Th4, are alternatively turned ON to obtain a nearly square wave current waveform. Two commutating capacitors – C1 in the upper half, and C2 in the lower half, are used. Four diodes, D1–D4 are connected in series with each thyristor to prevent the commutating capacitors from discharging into the load. The output frequency of the inverter is controlled in the usual way, i.e., by varying the half time period, (T/2), at which the thyristors in pair are triggered by pulses being fed to the respective gates by the control circuit, to turn them ON, as can be observed from the waveforms (Fig. 5.36). The inductance (L) is taken as the load in this case, the reason(s) for which need not be stated, being well known. The operation is explained by two modes.

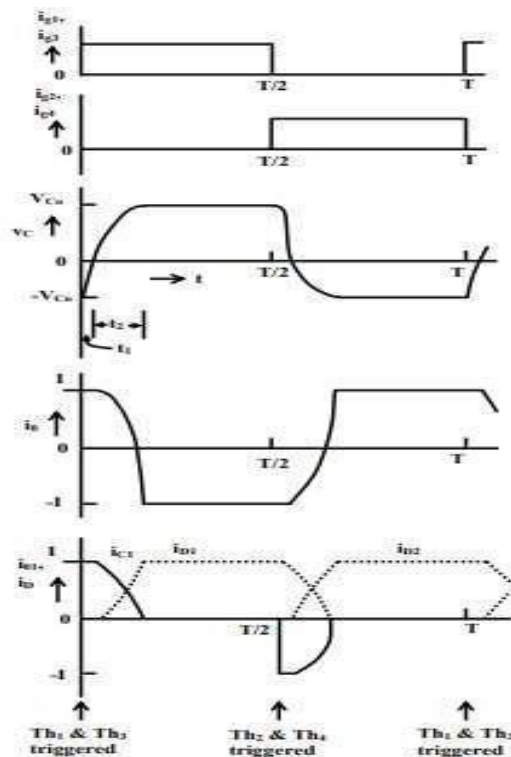

Figure: 5.36 output waveforms of Single phase current source inverter

Mode I: The circuit for this mode is shown in Fig. 5.37. The following are the assumptions. Starting from the instant, , the thyristor pair, Th – t = 0 2 & Th4, is conducting (ON), and the current (I) flows through the path, Th2, D2, load (L), D4, Th4, and source, I. The commutating capacitors are initially charged equally with the polarity as given, i.e., . This mans that both capacitors have right hand plate positive and left hand plate negative. If two capacitors are not charged initially, they have to pre-charge.

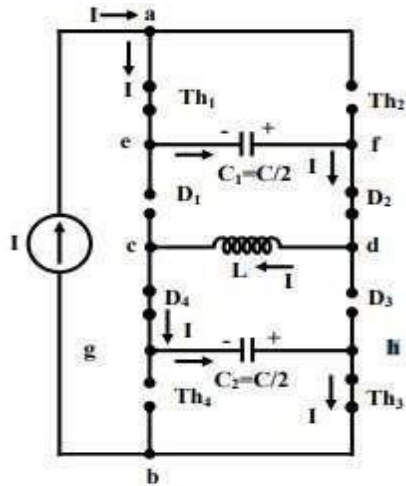

Figure: 5.37 Mode I operation of CSI

Mode II: The circuit for this mode is shown in Fig. 5.38. Diodes, D2 & D4, are already conducting, but at $t = t_1$, diodes, D1 & D3, get forward biased, and start conducting. Thus, at the end of time t_1 , all four diodes, D1–D4 conduct. As a result, the commutating capacitors now get connected in parallel with the load (L).

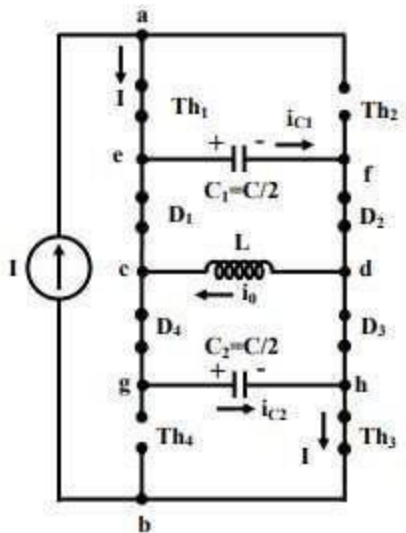

Figure: 5.38 Mode II operation of CSI

Load Commutated CSI

Two commutating capacitors, along with four diodes, are used in the circuit for commutation from one pair of thyristors to the second pair. Earlier, also in VSI, if the load is capacitive, it was shown that forced commutation may not be needed. The operation of a single-phase CSI with capacitive load (Fig. 5.39) is discussed here. It may be noted that the capacitor, C is assumed to be in parallel with resistive load (R). The capacitor, C is used for storing the charge, or voltage, to be used to force-commutate the conducting thyristor pair as will be shown. As was the case in the last lesson, a constant current source, or a voltage source with large inductance, is used as the input to the circuit.

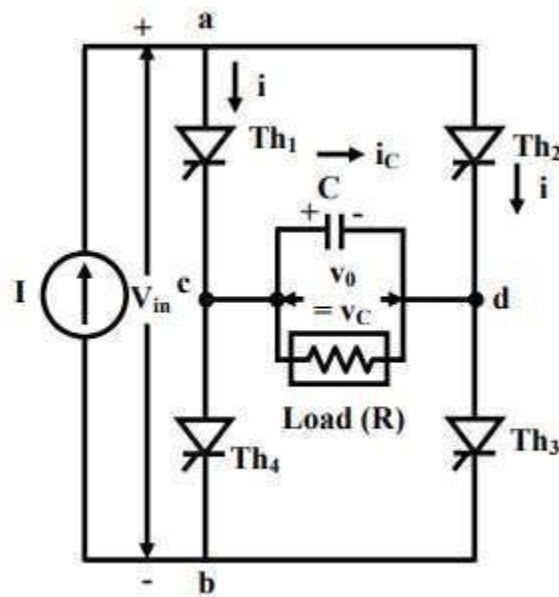

Figure: 5.39 Circuit diagram of load commutated CSI

The power switching devices used here is the same, i.e. four Thyristors only in a full- bridge configuration. The positive direction for load current and voltage is shown in Fig. 5.40 Before $t = 0$, the capacitor voltage is V_1 , i.e. the capacitor has left plate negative and right plate positive. At that time, the thyristor pair, Th_2 & Th_4 was conducting. When (at $t = 0$), the thyristor pair, Th_1 & Th_3 is triggered by the pulses fed at the gates, the conducting thyristor pair, Th_2 & Th_4 is reverse biased by the capacitor voltage $C = -V_1$, and turns off immediately. The current path is through Th_1 , load (parallel combination of R & C), Th_3 , and the source. The current in the thyristors is I_{Ti} , the output current is

$$I_{ac} = I$$

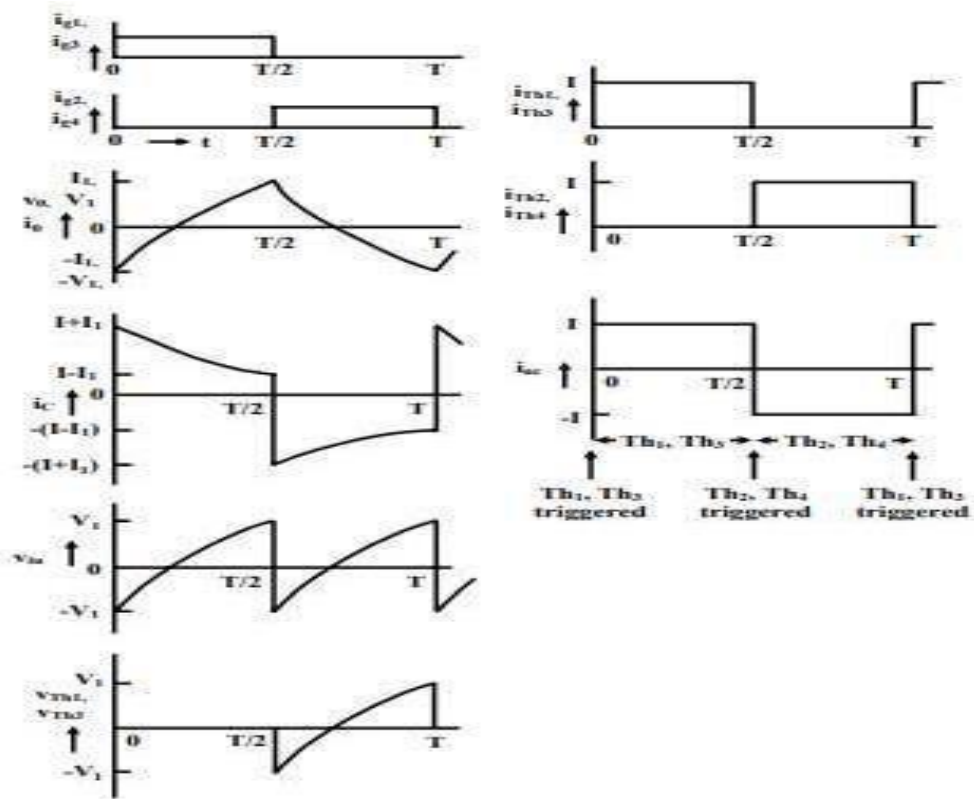

Figure: 5.40 Voltage and current waveforms of load commutated CSI

Numerical Problems

1. A single-phase half bridge inverter has a resistive load of 2.4 Ω and the d.c. input voltage of 48 V. Determine:-
 - (i) RMS output voltage at the fundamental frequency
 - (ii) Output power P_0
 - (iii) Average and peak currents of each transistor
 - (iv) Peak blocking voltage of each transistor.
 - (v) Total harmonic distortion and distortion factor.
 - (vi) Harmonic factor and distortion factor at the lowest order harmonic.

Solution:

(i) RMS output voltage of fundamental frequency, $E_1 = 0.9 \times 48 = 43.2$ V.

(ii) RMS output voltage, $E_{\text{orms}} = E = 48$ V.

Output power = $E^2/R = (48)^2/2.4 = 960$ W.

(iii) Peak transistor current = $I_p = Ed/R = 48/2.4 = 20$ A.

Average transistor current = $I_p/2 = 10$ A.

(iv) Peak reverse blocking voltage,

$VBR = 48$ V.

(v) RMS harmonic voltage

$$\begin{aligned} E_n &= \left[\sum_{n=3,5,7}^8 E_n^2 \right]^{-1/2} \\ &= (E_{\text{orms}}^2 - E_{1\text{rms}}^2)^{1/2} \\ &= [(48)^2 - (43.2)^2]^{1/2} \\ &= 20.92 \text{ V.} \end{aligned}$$

∴ $\text{THD} = \frac{20.92}{43.2} = 48.43\%$.

(vi)
$$\text{D.F.} = \frac{\left[\sum_{n=3,5,7}^{\infty} (E_n/n^2)^2 \right]^{1/2}}{0.9}$$
$$= \frac{0.03424}{0.9} = 3.8\%$$

(vii) Lowest order harmonic is the third harmonic. RMS value of third harmonic is

$$E_{3\text{rms}} = E_{1\text{rms}}/3$$

∴ $\text{H.F}_3 = E_{3\text{rms}}/E_{1\text{rms}} = 33.33\%$

and
$$\text{D.F.}_3 = (E_{3\text{rms}}/3^2)/E_{1\text{rms}}$$
$$= 1/27 = 3.704\%.$$

2. A single phase full bridge inverter has a resistive load of $R = 10 \Omega$ and the input voltage V_{dc} of 100 V. Find the average output voltage and rms output voltage at fundamental frequency.
3. A single PWM full bridge inverter feeds an RL load with $R=10\Omega$ and $L= 10$ mH. If the source voltage is 120V, find out the total harmonic distortion in the output voltage and in the load current. The width of each pulse is 120° and the output frequency is 50Hz.